



Coimisiún na Scrúduithe Stáit
State Examinations Commission

Leaving Certificate Examination 2006

Technical Drawing
Paper II(A) – Higher Level
(Engineering Applications)

(200 Marks)

Friday 16 June
Afternoon, 2.00 – 5.00

Instructions

- (a) *Ensure that you have received examination paper M84(L) which accompanies this paper.*
- (b) *Answer **any four** questions. All questions carry equal marks.*
- (c) *Drawings and sketches should be in pencil unless otherwise stated.*
- (d) *Where dimensions are omitted they may be estimated.*
- (e) *Credit will be given for neat orderly presentation of work.*
- (f) *Work on one side of the paper only.*
- (g) *The Examination Number should be written on each drawing sheet used.*
- (h) *First or third angle projection may be used.*

NOTE: All drawings are shown on examination paper M.84(L) which accompanies this paper.

1. Details of a Non-Return Valve are given in Fig. 1 with the parts list tabulated below.
- (a) Draw, full size, a sectional elevation of the assembly corresponding to the given sectional elevation of the body (part 1). Show the valve in the closed position.
 - (b) Insert item reference numbers to identify the parts and add the title NON-RETURN VALVE.
 - (c)
 - (i) With the aid of an arrow, placed at the inlet port on your drawing, show the direction of flow through the valve.
 - (ii) State the purpose of the 4mm diameter hole in the valve spindle (part 5).
 - (iii) When in use the valve was found to close too slowly on thick liquids. Using a neat freehand sketch suggest a modification to the design that would remedy this problem.

PART	NAME	REQUIRED
1	BODY	1
2	VALVE SEAT	1
3	VALVE	1
4	COVER	1
5	VALVE SPINDLE	1
6	M12 WASHER	1
7	M12 NUT	1
8	GASKET	1

2. (a) Draw the profile and displacement diagram for a plate cam rotating in a clockwise direction and imparting the following motion to an in-line roller follower of 20mm diameter:
- 0° to 60° rise 18mm with simple harmonic motion;
 - 60° to 150° dwell;
 - 150° to 330° rise 42 mm with uniform acceleration and retardation;
 - 330° to 360° dwell;
- At 360° the follower instantly falls 60mm.
- The nearest approach of the roller centre to the camshaft centre is 35mm.
The camshaft diameter is 25mm.
- (b) The quick return mechanism of a shaping machine is shown diagrammatically in Fig. 2. The crank OD rotates uniformly anticlockwise about fixed point O at a constant speed. The slotted arm AB oscillates about the fixed point A. The crank end D is fixed to a block, which slides along AB. The ram end C of the coupling rod BC is constrained to slide horizontally.
- Draw the given mechanism, in line diagram format, and plot the locus of point P during one complete revolution of the crank OD.

3. A sheet metal transition piece, used to connect a rectangular duct to a cylindrical pipe, is shown in Fig. 3.
- To a scale of 1:10, draw the given views and produce a one-piece surface development of the transition piece with the seam at S-S.
 - Show the minimum size of rectangular sheet that will contain the development.
 - The seam S-S is to be joined using a **Single Grooved Seam**.
 - Make a neat freehand sketch of this joint type.
 - Using a separate sketch, show the seam allowance necessary to make the joint.
4. (a) The projections of a machine screw jack are shown in Fig. 4. Make an exploded isometric drawing of the jack. The drawing should show clearly how the parts labelled 1, 2 and 3 are assembled. Corner X is to be the lowest point on your drawing.
- (b) From the following data, make a fully detailed working drawing of a right-angled pipe bend with flanges:
- Pipe:** Internal bore diameter 40mm;
 Wall thickness 5mm;
 Mean radius of bend 120mm;
 Angle of bend 90° .
- Flanges:** One flange at each end of pipe bend;
 Flanges welded to pipe using a 4mm fillet weld;
 Outside flange diameter 100mm x 15mm thick;
 Bore diameter 40mm;
 Four equally spaced 12mm diameter bolt holes on 80mm PCD.
- The working drawing should show a front and side elevation of the assembled bend with hidden detail and should be fully dimensioned.
5. (a) Fig 5(a) shows a pictorial view of a helical chute from a child's toy garage. The relative positions of the rectangular ends of the chute are shown in Fig 5(b). The helix rotates about the central support column through an angle of 540° as shown.
- Draw a plan and elevation of the chute and column showing all helical curves. (*Hidden detail should be shown. Ignore the wall thickness of the chute.*)
- (b) A playing piece from a child's game is shown in Fig 5(c). The piece is to be cast in metal. The angles between all four arms are equal so that it always stands with one arm pointing vertically upwards.
- Using a line diagram, determine the angle between any two arms.
- Note: The arms are all of equal length such that the playing piece would fit within a regular tetrahedron.*

6. Answer SECTION A or SECTION B but not both.

SECTION A

- (a) An involute gear wheel with 24 teeth, 20° pressure angle and module 10 is in mesh with a rack.

Draw the gear and rack in mesh, showing **two** teeth on the gear and **three** teeth on the rack. Tabulate, on the sheet, the following values for the gear wheel:

- Addendum
- Pitch Circle Diameter
- Tooth Thickness
- Dedendum
- Circular Pitch
- Base Circle Diameter

- (b) A sectional elevation of a single-plate clutch is shown in Fig. 6(a). The following twelve parts are identified with item reference numbers 1 to 12: Pressure spring, Pressure plate, Flywheel, Spigot bush, Adjustable link, Clutch lining, Driving stud, Operating fork, Drive shaft to gearbox, Drive shaft from engine, Pedal, Ring gear.

- (i) Draw a parts list, which shows the item number and name for **each** of these parts.
- (ii) With the aid of neat annotated sketches, briefly explain the operation of the clutch.
- (iii) In a clutch a thrust bearing is often used in place of item 12. Make a neat freehand sectional sketch showing the construction of a typical thrust bearing.

OR
SECTION B

- (a) **Briefly** answer any **six** of the following questions.
(*Sketches should be used where appropriate*)
- (i) State **four** advantages of using CAD instead of traditional drawing methods;
 - (ii) Explain what is meant by the term '*Parametric CAD System*';
 - (iii) Sketch the following CAD Linetypes: DASHED and ZIGZAG;
 - (iv) Using a sketch explain how layers or levels may be used in the organisation of an engineering CAD drawing;
 - (v) Sketch an example of *Ordinate* dimensioning;
 - (vi) Explain, with the aid of a sketch, what is meant by a '*drawing template*';
 - (vii) Sketch the result of applying an '*oblique angle*' of 30^0 to a horizontal dimension;
 - (viii) Explain the purpose of a '*Hyperlink*' in an on-line CAD drawing.
- (b) Name a CAD package that could be used to produce the **3D model** of the component shown in Fig. 6(b). Using sketches, where appropriate, briefly outline the various steps involved and the commands used in generating the model.
- (c) With reference to CAD and using freehand sketches where appropriate, explain the difference between the following pairs of terms:
- (i) ***Scale*** and ***Zoom***;
 - (ii) ***Text Align*** and ***Text Fit***;
 - (iii) ***Associative dimensions*** and ***non associative dimensions***;
 - (iv) ***Wireframe models*** and ***Solid models***;
 - (v) ***Raster files*** and ***Vector files***.
- (d) Draw, full size, the object that would be displayed on a CAD system when the following commands are executed. The origin (0,0) is located at the lower left corner of the display.
- Sheet size is set. Lower left corner (0,0) and upper right corner (400,250).
 - A circle is drawn, Centre point (110,65), Radius 45.
 - An ellipse is drawn with a major axis start point of (300,225) and a major axis end point of (300,125). The minor axis is 80mm long.
 - A line is drawn, starting at the point (300,200) and ending at the point defined by the relative polar coordinates(@30<0). Another line is drawn, starting at the point (300,150) and ending at the point defined by the relative coordinates (@30,0). These two lines are extended to the right to meet the ellipse and the portion of the ellipse intercepted between them is trimmed out.
 - A 3-point arc is drawn. Start point (300,200), second point (285,175) and end point (300,150)
 - A six sided polygon is drawn. Centre of polygon (110,65), circumscribed about a circle of radius 25mm.
 - A line is drawn, starting at the point (130,100) and ending at the point defined by the relative polar coordinates(@160<30). This line is offset, by 40mm, in the direction of the lower right hand corner of the sheet.
 - The four intersections between the last two lines drawn and the circle and ellipse are filleted with a 10mm radius.
 - A circle is drawn, Centre point (170,100), Radius 10. This circle is subjected to a rectangular array with one row and three columns. The column array distance is 40mm and the angle for the array is 30^0 .



Scrúdú Ardteistiméireachta 2006
Leaving Certificate Examination 2006

Líníocht Theicniúil

Technical Drawing

Páipéar II(A) – Ardleibhéal
Paper II(A) – Higher Level

(Feidhmiúcháin Innealtóireachta)
(Engineering Applications)

Dé hAoine 16 Meitheamh, Tráthnóna, 2.00 - 5.00
Friday 16 June, Afternoon, 2.00 - 5.00

NÓTA: Deimhnigh go bhfuair tú scrúdpháipéar M.84, a ghabhann leis an bpáipéar seo.
NOTE: Ensure that you have received examination paper M.84 which accompanies this paper.

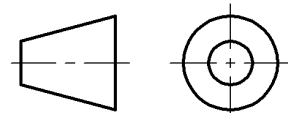
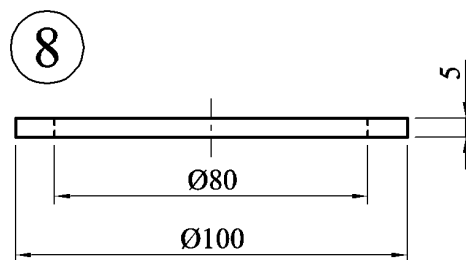
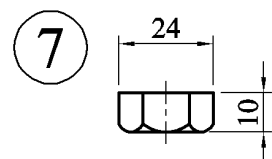
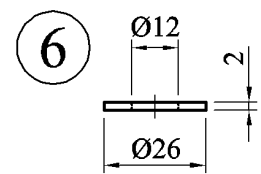
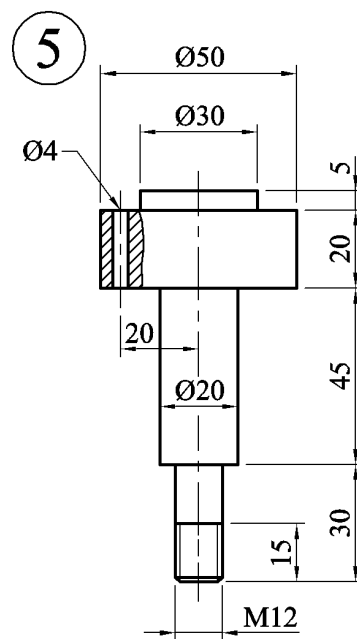
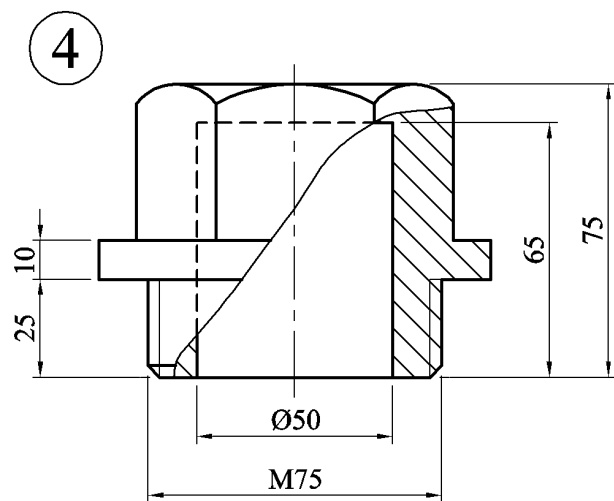
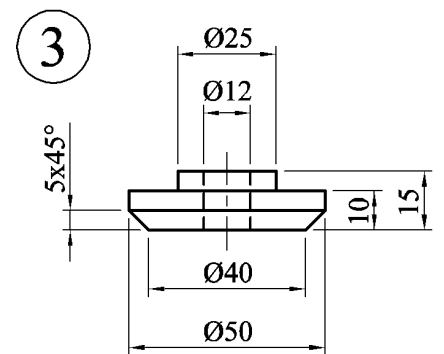
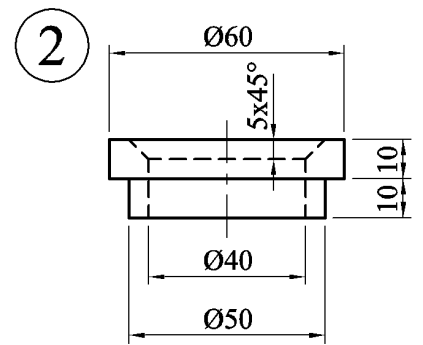
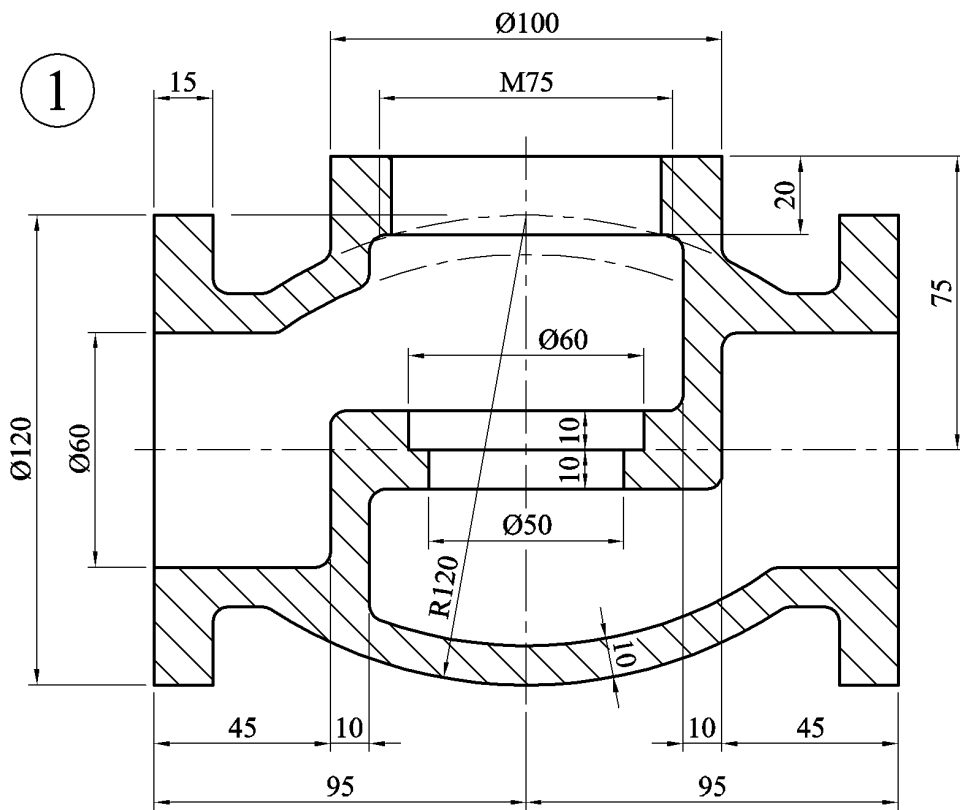

Fillets / Filléid R3

Fig. 1 / Fíor 1

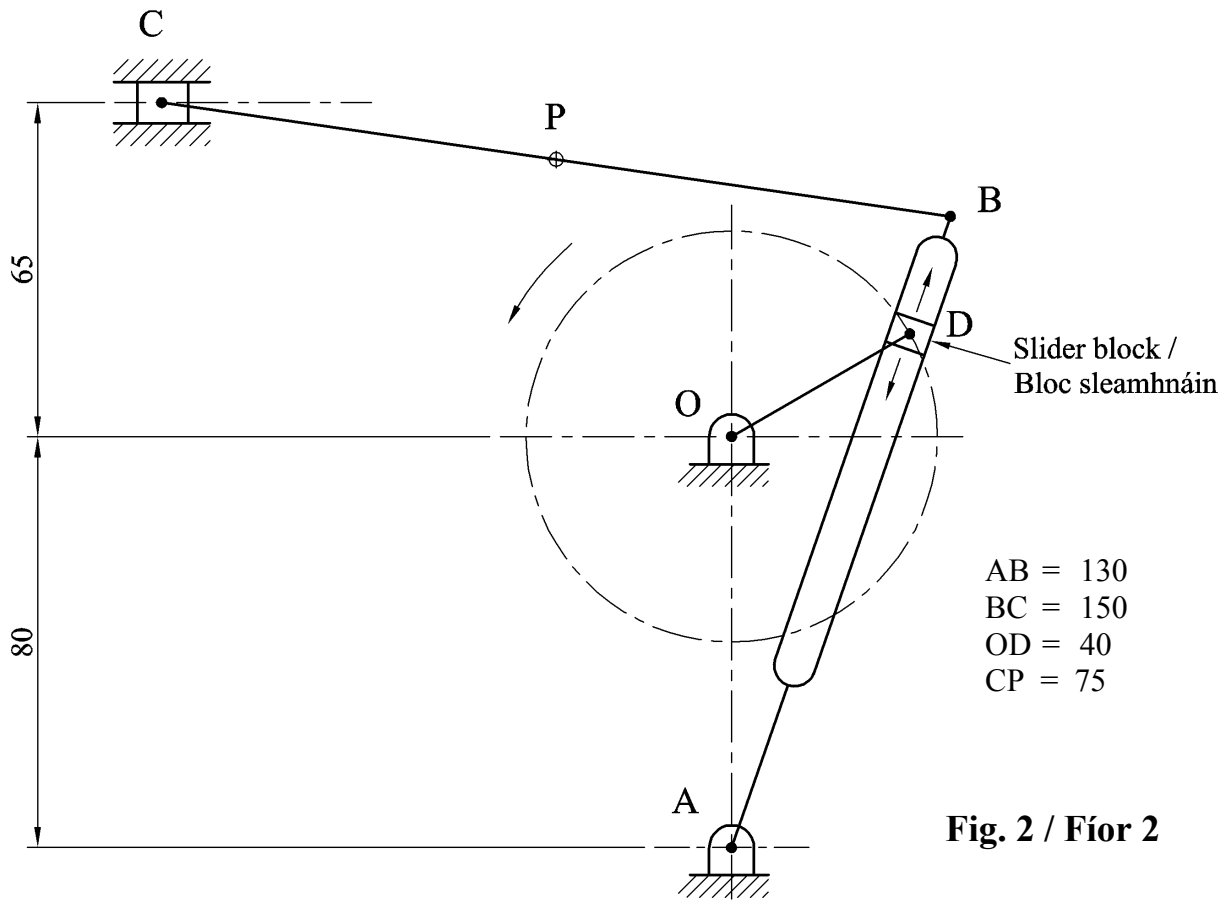

Fig. 2 / Fíor 2

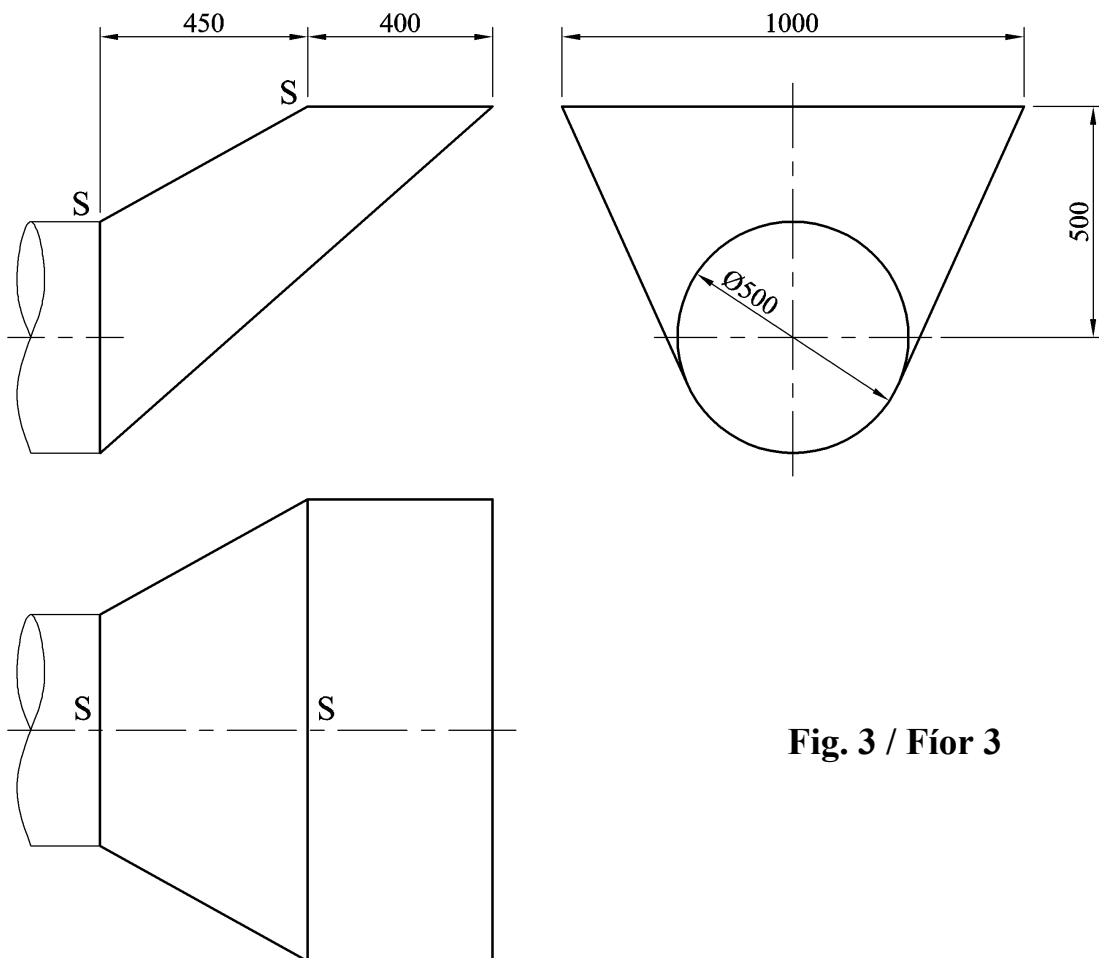

Fig. 3 / Fíor 3

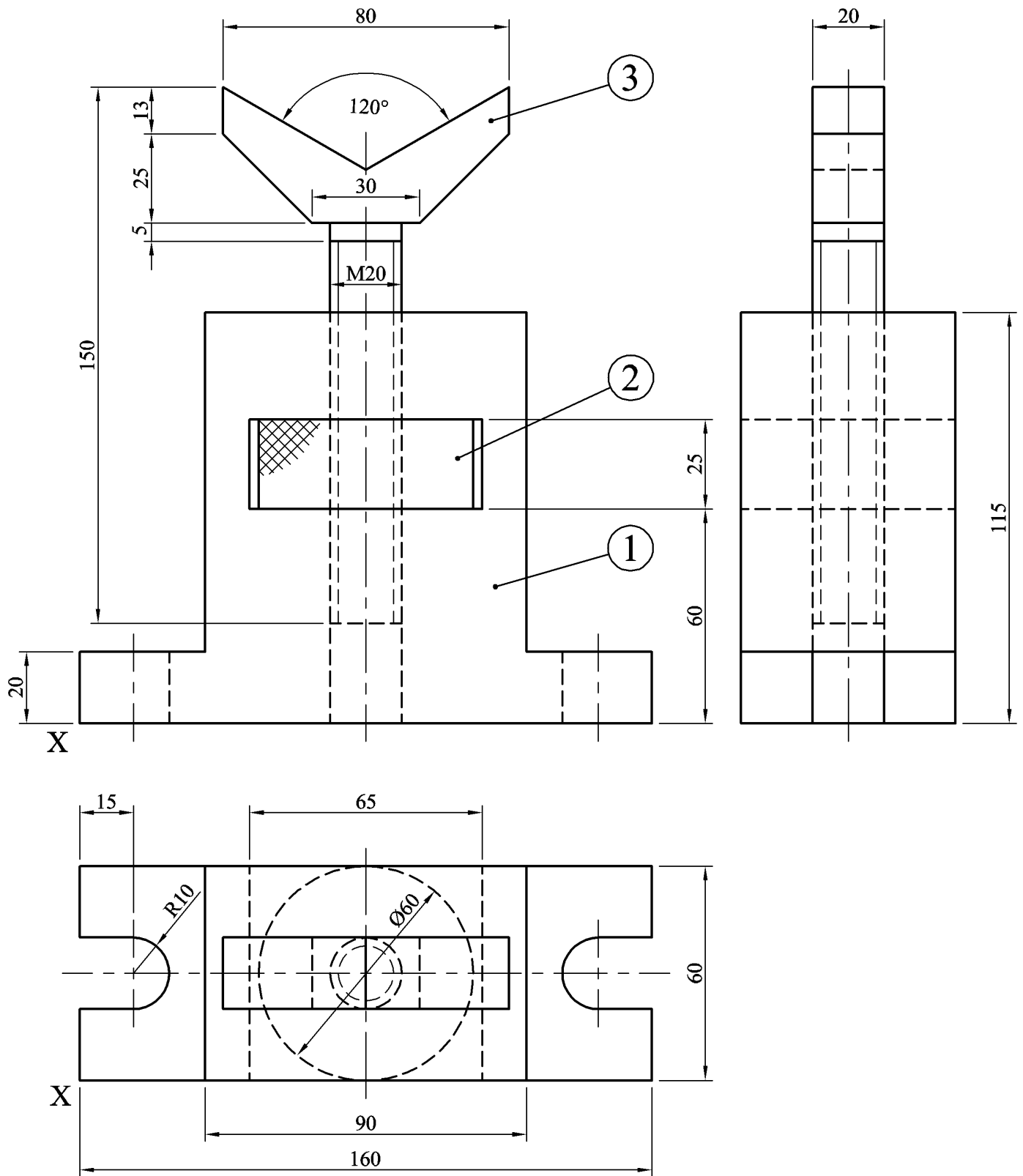

Fig. 4 / Fíor 4

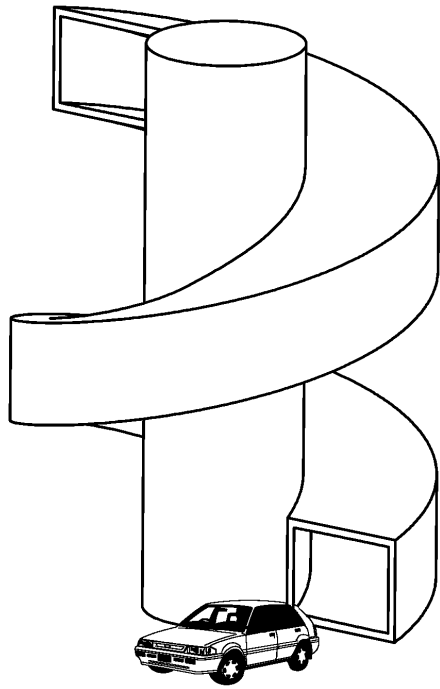

Fig. 5(a) / Fíor 5(a)

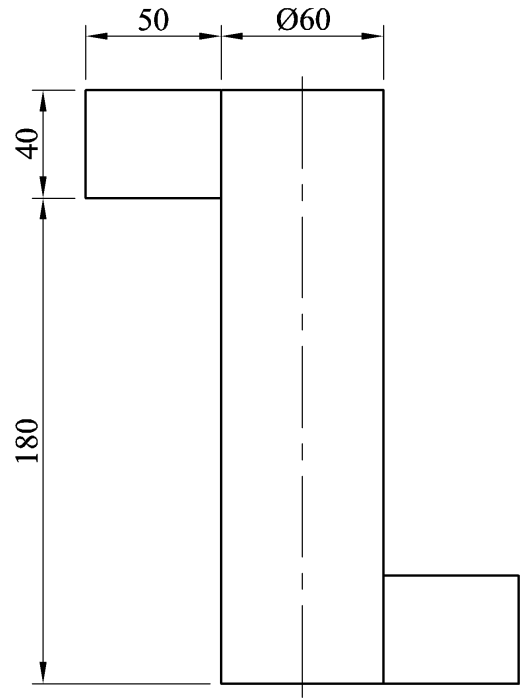
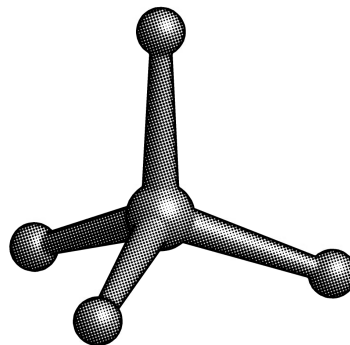

Fig. 5(b) / Fíor 5(b)

**Fig. 5(c) /
Fíor 5(c)**



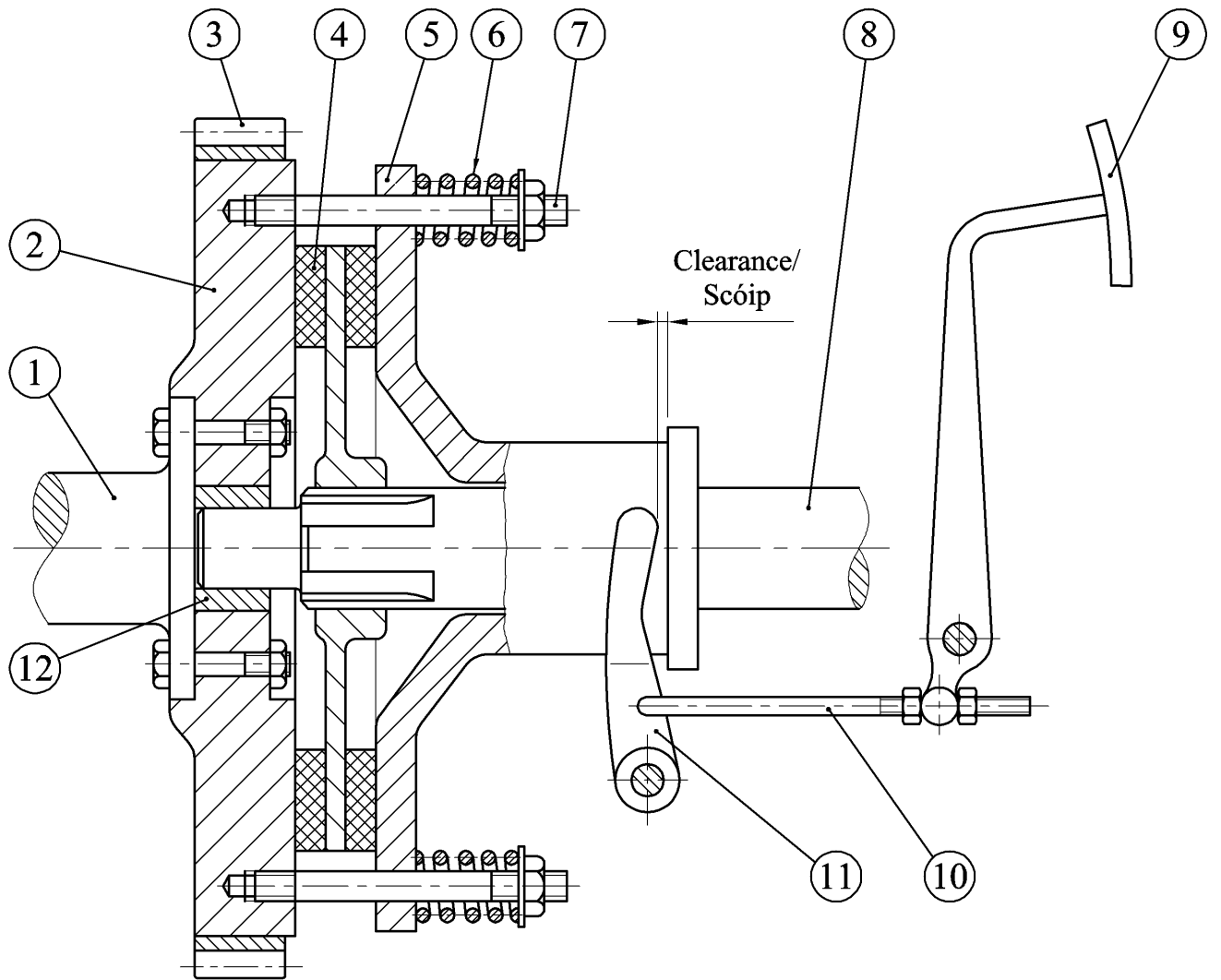

Fig. 6(a) / Fíor 6(a)

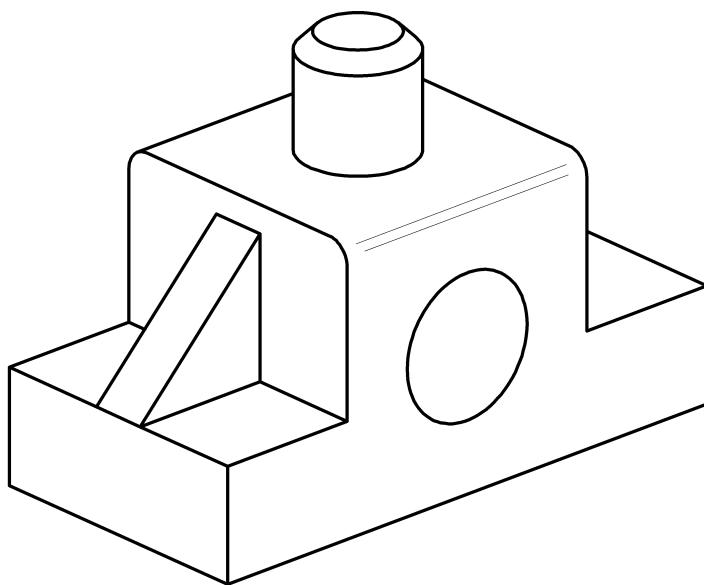

Fig. 6(b) / Fíor 6(b)