

AN ROINN OIDEACHAIS
(Department of Education).

BRAINSE AN MHEAN-OIDEACHAIS
(Secondary Education Branch).

LEAVING CERTIFICATE EXAMINATION, 1926.

HONOURS

MECHANICAL DRAWING AND DESIGN.
BOYS AND GIRLS.

TUESDAY, 22nd JUNE.—AFTERNOON, 4 to 6 P.M.

BOYS ONLY.

NOTE.—The use of mathematical instruments, protractors, scales, T and set squares, and drawing-boards is allowed.

ALL questions to be attempted.

All construction lines must be clearly shown.

The number of the question must be distinctly marked by the side of each answer. Both sides of the paper may be used.

Questions marked (*) have accompanying diagrams.

*Q. 1. Make a drawing of the calipers (full size) to the dimensions given. Show clearly the construction by which you would determine the tangents.

*Q. 2. The plan and elevation of a pentagonal right prism are given. Draw an elevation on the line X^1Y^1 , which makes an angle of 30° with the long edges of the prism and show the section made by the vertical plane ST.

*Q. 3. The front and end views of a saw-horse are given. Draw the plan to a scale of $\frac{1}{10}$ full size.

Q. 4. A distance of 7 yards is represented by $4\frac{1}{2}$ inches on a map. Make a diagonal scale for the map by which yards, feet, and inches can be measured. Figure the scale properly, and show by two small marks on it how you would take off a distance of 1 yard, 2 feet, 7 inches.

*Q. 5. The figure shows the plan and elevation of a mirror and stand. Draw the plan and elevation as given of the stand to a scale of one inch to one foot. Show the plan and elevation of the mirror (thickness omitted) when tilted at an angle of 45° to the horizontal plane.

Q. 6. Make a design to advertise an article of Irish manufacture, the name of the article to form an important part of the design. The design may be in black and white, or two tones of one colour, or two colours, and should not exceed 84 square inches in area. State the method by which your design could be reproduced.

Or,

Draw a design to fill a square panel, 8-inch side, exclusive of marginal lines or bands. The design must include a shield or cartouche bearing the word "FÁILTE" or "WELCOME." The design may be composed of Celtic ornament, scroll work or natural forms ornamentally treated. State the material in which the design could be suitably carried out.

GIRLS ONLY.

NOTE.—The use of mathematical instruments, protractors, scales, T and set squares, and drawing-boards is allowed.

ALL questions to be attempted.

All construction lines must be clearly shown.

The number of the question must be distinctly marked by the side of each answer. Both sides of the paper may be used.

Questions marked (*) have accompanying diagrams.

*Q. 1. An embroidered border composed of geometric and freely-drawn forms is given. Draw two repeats according to the figured dimensions.

*Q. 2. The diagram of a fan is given. Draw full size, adhering to the figured dimensions. It will be sufficient to finish half the diagram.

*Q. 3. The given figure represents an octagonal tile. Draw full size to the dimension indicated.

*Q. 4. A repeating pattern composed of quatrefoils is given. Draw full size, according to the dimensions shown, the portion enclosed by the chain lines. Show how you would determine the centres of the arcs and the points of contact.

*Q. 5. The plan and elevation of a hexagonal tea-caddy are given. The sloping faces of lid make angles of 45° with the horizontal. Draw an elevation on the line X¹Y¹ and show the ornament on the face A in elevation.

The true shape of one face with ornament thereon is given.

Q. 6. Make a design for a cushion-cover to occupy a square of nine-inch side, or a circle of nine inches diameter.

An initial letter or monogram to form an important part of the design.

The design should be adapted to embroidery or stencilling. The method chosen to be stated.

Or,

Make a design for a book-cover nine inches by six inches. The design to include the word "POEMS" or "POEMS." The design may be based on Celtic ornament or on natural forms ornamentally treated. State by what method and in what material your design could be suitably carried out.

GIRLS ONLY.

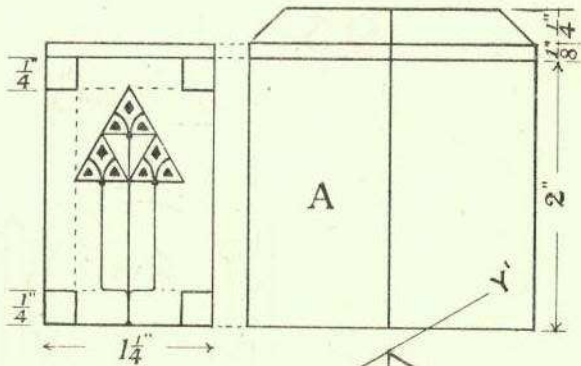
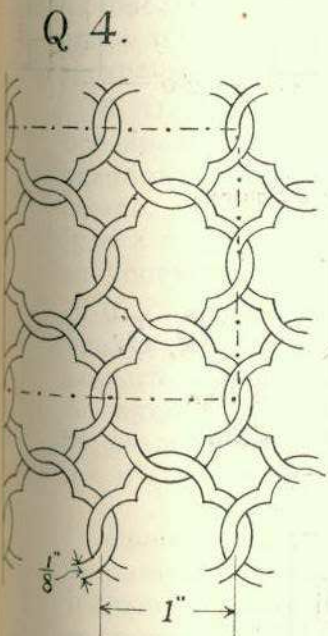
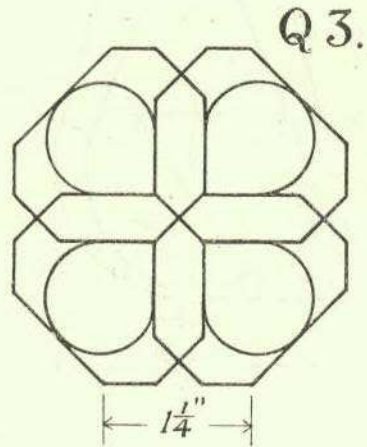
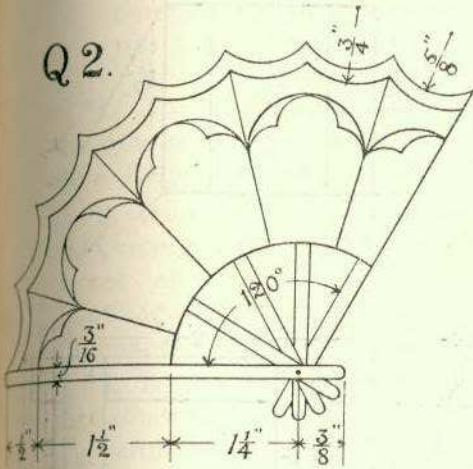
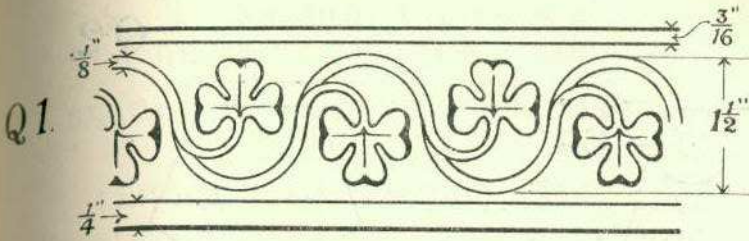

Q5.

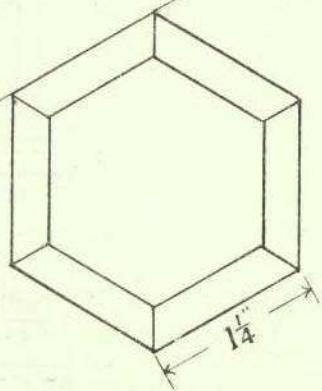

BOYS ONLY.

Q1.

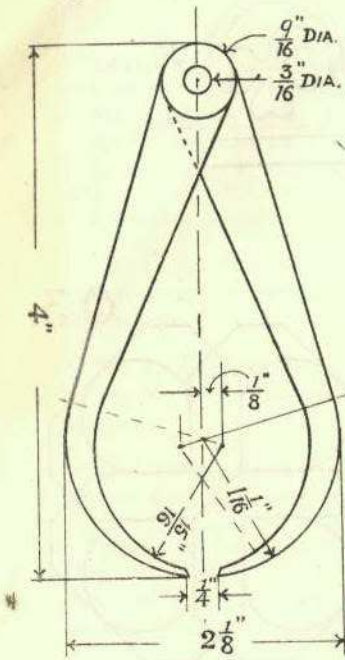

Q2.

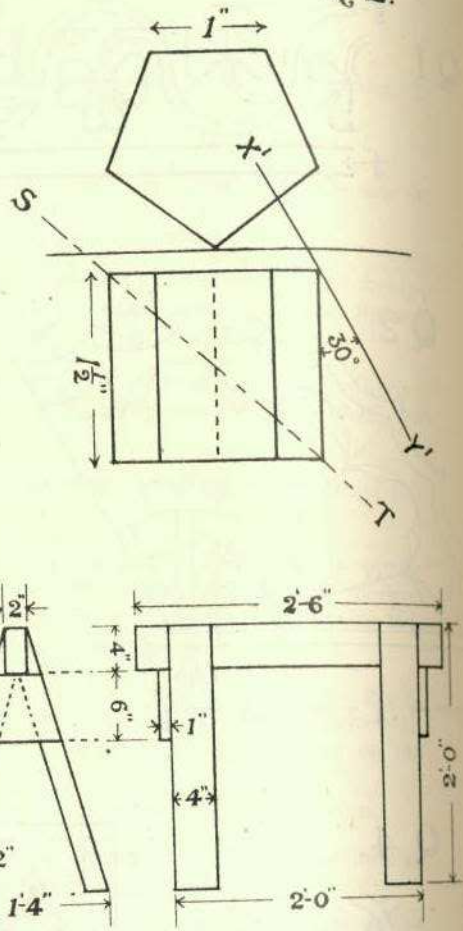

Q3.

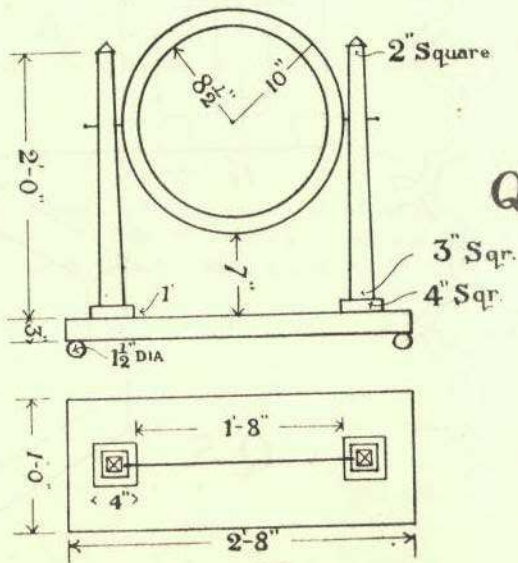
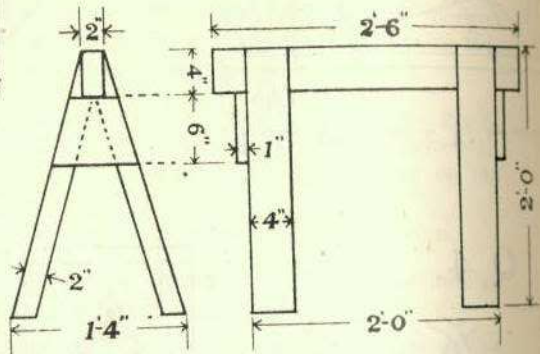

Q5.