

AN ROINN OIDEACHAIS.

AN BRAINSE GAIRM-OIDEACHAIS.

CERTIFICATE EXAMINATIONS

for

DAY VOCATIONAL COURSES, 1952.

**MECHANICAL DRAWING.**

Tuesday, 24th June—10–12.30 p.m.

INSTRUCTIONS.

- (a) Not more than four questions may be attempted, two of these must be selected from Section A and two selected from Section B. Draw questions from Section A on one sheet of paper, and questions from Section B on a separate sheet.
- (b) A maximum of ten marks will be awarded for accuracy and neatness of arrangement.
- (c) The number of the question must be distinctly marked by the side of each answer.
- (d) Work on one side of the paper only.
- (e) Examination Number must be distinctly marked on each sheet of drawing paper.

SECTION A.

1. Fig. 1 shows a pictorial view of a "Display Stand." Draw the following views of the object to a scale *half full size* :—

- (a) A front elevation looking in the direction of the arrow A.
- (b) A side elevation looking in the direction of the arrow B.
- (c) A plan projected from the front elevation.

Insert four of the main dimensions and title your drawing "DISPLAY STAND" in capitals  $\frac{1}{4}$ " high.

[25 marks.]

]P.T.O.

2. Fig. 2 represents the elevation and plan of a hexagonal prism cut by a plane inclined at  $30^\circ$  to the horizontal. Make a full size drawing of this elevation and plan, and then show the following :—

- (a) Side elevation looking in the direction of the arrow A.
- (b) The true shape of the section cut by the inclined plane.

Indicate by lettering-in on your plan and side elevation, the position of the points O, N, B and D.

[25 marks.]

3. Fig. 3 is a pictorial view of an open tray with side lugs. The sides are at right angles to the bottom, while one end is inclined outwards at an angle of  $120^\circ$ , and the other end is part of a cylinder. Draw full size the complete development of the tray.

Neglect allowance for joints.

(Development of cylinder).

[25 marks.]

4. Make an Isometric drawing of the object shown in Fig. 4.

[25 marks.]

### SECTION B.

5. Fig. 5 represents part of the ornamental ironwork for a gate. Make a scale of 3 inches to one foot, to read inches, overall length two feet. Using this scale, reproduce the drawing, showing the construction lines for at least one half.

(Tangents to circles).

[20 marks.]

6. Reproduce, full size, the moulding shown in Fig. 6. Draw by radial projection, an outline similar to this moulding, reducing the height AB to  $2\frac{1}{2}$  inches.

(Radiating lines.)

[20 marks.]

7. Fig. 7 is the face of a piece of timber the centre of which is divided up into *squares* of contrasting hardwoods. The lengths of diagonals A, B and C of these squares are in the ratio 1 : 2 : 3.

Make a full size drawing similar to the figure.

(Proportional division of lines).

[20 marks.]

8. Given that the diagonal AC of a rectangle ABCD is  $3\frac{1}{2}$  inches long and the side AB  $1\frac{3}{4}$  inches long, construct the rectangle.

Measure and write down the length of the side BC and the size of the angle BAC.

[20 marks.]

# — Линіо́т Ме́чнїу́л —

— 1952 —

— Сайм-Сўмсај 1ае —

— SCRÚDÚCÁJN TEASTAJŠ —

①

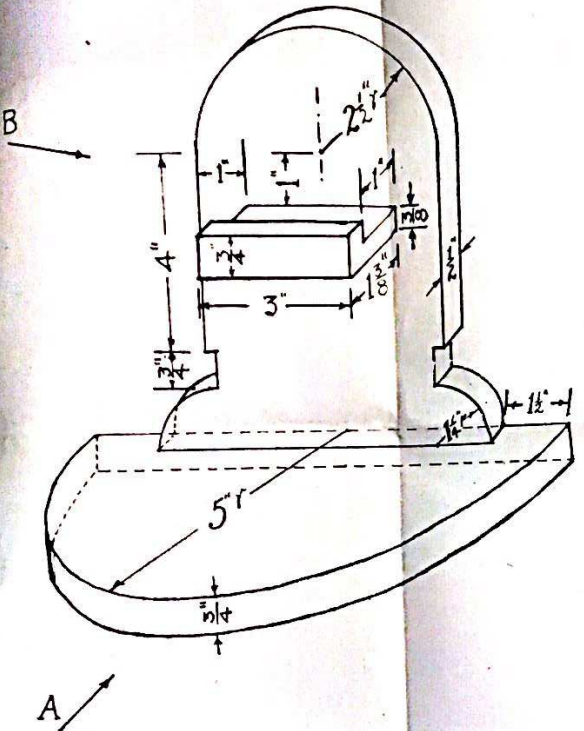

②

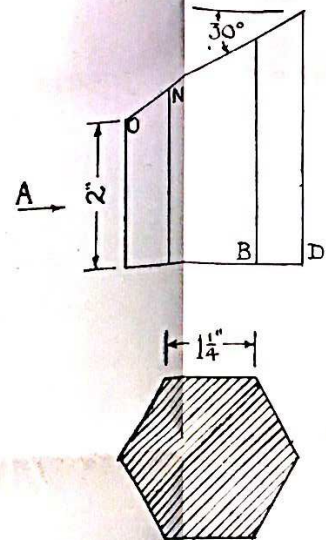

⑤

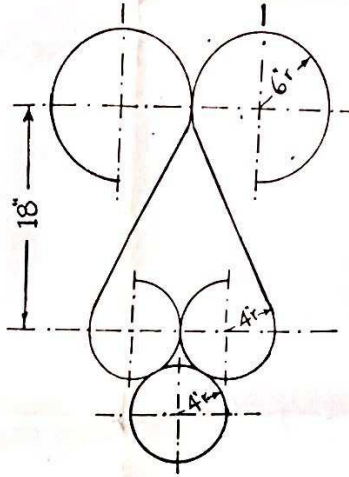

⑥

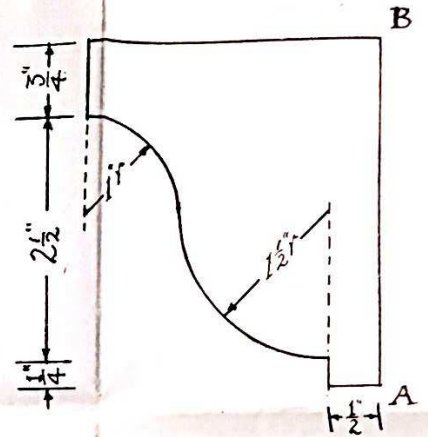

⑦

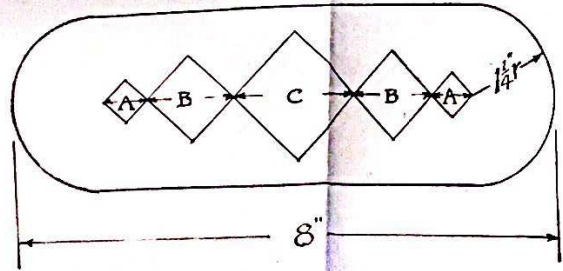

③

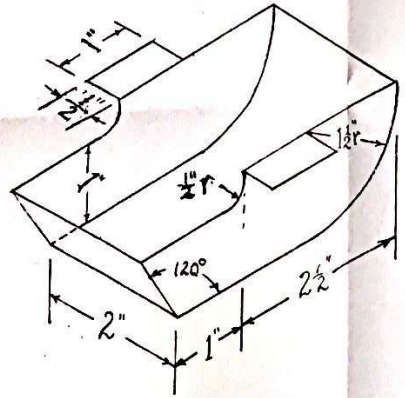

④

