



# Coimisiún na Scrúduithe Stáit State Examinations Commission

S36

JUNIOR CERTIFICATE EXAMINATION, 2003

## SCIENCE - ORDINARY LEVEL

[N.B. Not for Science – Local Studies Candidates]

THURSDAY, 12 JUNE – AFTERNOON, 2.00 to 4.30

### INSTRUCTIONS

1. Write your **examination number** in the box provided on this page.
2. Answer **SECTION A**.
3. Answer **ANY THREE SECTIONS** from **SECTIONS B, C, D, E**.
4. Answer **all questions** in the spaces provided. If you require extra space, there are pages provided at the back of this booklet.

<b>Centre Number</b>
<b>Examination Number</b>

**For examiner use only**

1. Total of end of page totals	
2. Aggregate total of all disallowed question(s)	
3. Total marks awarded (1 minus 2)	

**For examiner use only**

QUESTION	MARK	
Section A	Q.1	
Section B	Q.2	
	Q.3	
	Q.4	
Section C	Q.5	
	Q.6	
	Q.7	
Section D	Q.8	
	Q.9	
	Q.10	
Section E	Q.11	
	Q.12	
	Q.13	
	Q.14	
	Q.15	
	Q.16	

<b>TOTAL</b>	
--------------	--

<b>GRADE</b>	
--------------	--

**SECTION A – CORE (144 MARKS)**

**Answer any 12 parts (a), (b), (c), etc. from this Section.**

**Question 1**

(a) Name the following pieces of apparatus.

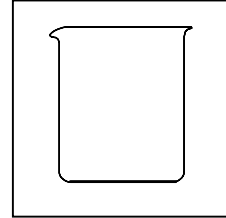
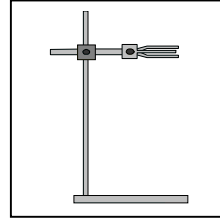
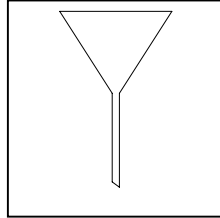
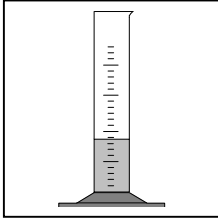

**NAME** \_\_\_\_\_

(b) Energy sources can be **renewable** or **non-renewable**.

Give **two** examples of **renewable** sources of energy.

1 \_\_\_\_\_ 2 \_\_\_\_\_

Give **two** examples of **non-renewable** sources of energy.

1 \_\_\_\_\_ 2 \_\_\_\_\_

(c) What is **measured** in each of the following units?

Kilogram (kg) \_\_\_\_\_

Centimetre cubed (cm<sup>3</sup>) \_\_\_\_\_

Kilowatt hour (kW h) \_\_\_\_\_

Metre squared (m<sup>2</sup>) \_\_\_\_\_

(d) Choose a **word** from the list on the right to match each of the **symbols** below.

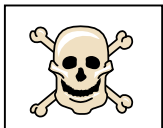

\_\_\_\_\_



\_\_\_\_\_

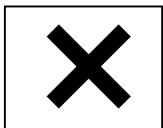

\_\_\_\_\_



\_\_\_\_\_

- IRRITANT
- TOXIC
- FLAMMABLE
- RADIOACTIVE

(e) The flask in the diagram is **heated gently**.

What happens to the **water level** in the tube?

\_\_\_\_\_

**Why** does this happen?

\_\_\_\_\_

What happens to the **water level** in the tube when the flask is **allowed to cool**? \_\_\_\_\_

Name an **instrument** that works on this principle.

\_\_\_\_\_

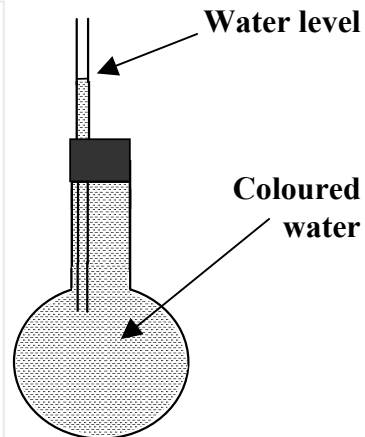

(f) Choose a **substance** from the list on the right which is

used to **measure the pH** of an acid \_\_\_\_\_

an **alkali metal** \_\_\_\_\_

an element found in **fuels** \_\_\_\_\_

a gas found in **air** \_\_\_\_\_

- CARBON
- UNIVERSAL INDICATOR
- NITROGEN
- SODIUM

(g) The diagram shows part of an experiment to find out **what causes iron to rust**.

In **which** of the test-tubes will the nail rust?

\_\_\_\_\_

Why was the water **boiled** in test-tube **B**?

\_\_\_\_\_

Give **two** ways to stop iron rusting.

1 \_\_\_\_\_

2 \_\_\_\_\_

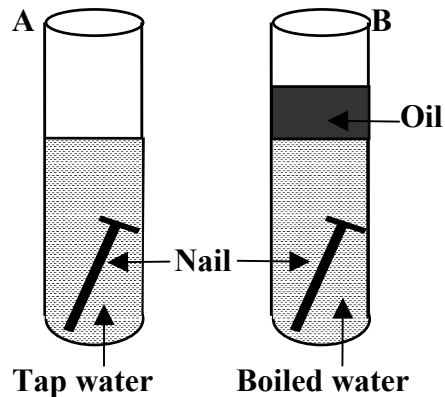

(h) State whether each of the following is a **physical change** or a **chemical change**.

**MELTING OF ICE**  
**COOKING OF FOOD**

**BURNING OF WOOD**  
**DISSOLVING SUGAR IN TEA**

PHYSICAL CHANGE	CHEMICAL CHANGE

(i) When **iron filings and sulphur** are mixed together a **mixture** is formed.

A \_\_\_\_\_ can be used to **separate** the iron filings from the sulphur.

A mixture of iron filings and sulphur can be changed into the **compound** iron sulphide by \_\_\_\_\_.

**One** other example of a **mixture** is \_\_\_\_\_.

**One** other example of a **compound** is \_\_\_\_\_.

(j) Water **boils** at \_\_\_\_\_ °C.

Water **freezes** at \_\_\_\_\_ °C.

The pin in the diagram does not sink because of **surface** \_\_\_\_\_.

How does this help **water insects**?

\_\_\_\_\_

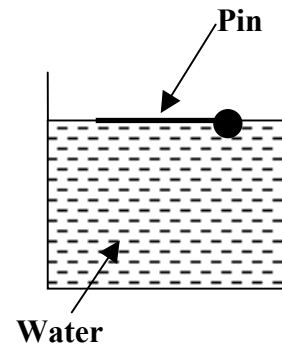

(k) Micro-organisms such as **fungi, bacteria** and **viruses** can be both **useful** and **harmful**.

State **one** way in which **fungi** are **useful** to people. \_\_\_\_\_

State **one** way in which **fungi** are **harmful** to people. \_\_\_\_\_

Give **one** use of **bacteria**. \_\_\_\_\_

Name a **disease** caused by a **virus**. \_\_\_\_\_

(l) Wholemeal brown bread is a good source of both **fibre** and **starch**.

The **function** of **fibre** in the diet is to prevent \_\_\_\_\_.

Another **food** which is a good source of fibre is \_\_\_\_\_.

The **function** of **starch** in the diet is \_\_\_\_\_.

The **chemical** you would use to test for starch is \_\_\_\_\_.

(m) **Pollution** is caused by substances that harm the environment.

Name **one** substance that causes **water pollution**. \_\_\_\_\_

State **one** way in which humans can **reduce** water pollution.

\_\_\_\_\_

Name **one** substance that causes **air pollution**. \_\_\_\_\_

State **one** way in which humans can **reduce** air pollution.

\_\_\_\_\_

(n) In the male body **sperm** is produced in the \_\_\_\_\_.

In the female body the **egg** is produced in the \_\_\_\_\_.

The **joining** of the **sperm** with the **egg** is called \_\_\_\_\_.

The **egg** is **released** about the \_\_\_\_\_ **day** of the female menstrual cycle.

(o) Choose an **organ** or **part of the human body** from the list on the right, which

**pumps** blood around the body \_\_\_\_\_

passes **oxygen** into the body \_\_\_\_\_

makes **urine** \_\_\_\_\_

carries **messages** to the brain \_\_\_\_\_

**BREATHING SYSTEM**

**KIDNEY**

**HEART**

**NERVES**

SECTION B – PHYSICS (72 MARKS)

There are THREE questions in this Section. Answer any TWO of these questions.

Question 2

(a) Choose a **piece of equipment** from the list on the right that is used when measuring

the **diameter** of a pipe \_\_\_\_\_ (3)

the **length** of a curved line \_\_\_\_\_ (3)

the **volume** of a stone \_\_\_\_\_ (3)

the **mass** of a solid \_\_\_\_\_ (3)

- BALANCE
- CALLIPERS
- OPISOMETER
- OVERFLOW CAN

(b) A student is required to **measure** the speed of a bicycle.

What **unit** was the **distance** measured in? \_\_\_\_\_ (3)

What **unit** was the **time** measured in? \_\_\_\_\_ (3)

**Speed** = distance \_\_\_\_\_ by time. (3)

What is the **unit** of **speed**? \_\_\_\_\_ (3)

(c) Describe, with the aid of a labelled diagram, an experiment to **show that oil reduces friction**. (12)

\_\_\_\_\_

\_\_\_\_\_

\_\_\_\_\_

\_\_\_\_\_

\_\_\_\_\_

\_\_\_\_\_

\_\_\_\_\_

\_\_\_\_\_

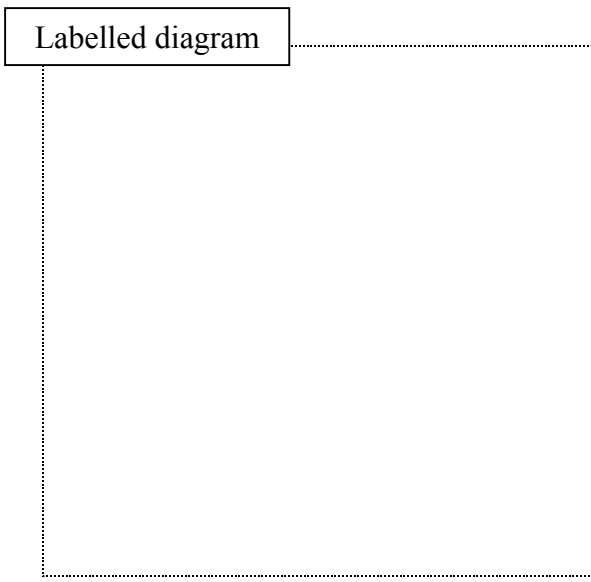

**Question 3**

(a) Choose a **word** from the list on the right to **complete** the sentences below.

Heat travels through **liquids** by \_\_\_\_\_ (3)

**Heat** is a form of \_\_\_\_\_ (3)

**Wool** is a good \_\_\_\_\_ (3)

An **electric fire** heats a room by \_\_\_\_\_ (3)

- ENERGY**
- INSULATOR**
- RADIATION**
- CONVECTION**

(b) The diagram shows the **changes of state of water**. What do the letters **A**, **B**, **C** and **D** stand for?



- A** \_\_\_\_\_ (3)
- B** \_\_\_\_\_ (3)
- C** \_\_\_\_\_ (3)
- D** \_\_\_\_\_ (3)

(c) You are given four rods made of different metals. Describe, with the aid of a labelled diagram, an experiment to **show which of the metals is the best conductor of heat**. (12)

\_\_\_\_\_

\_\_\_\_\_

\_\_\_\_\_

\_\_\_\_\_

\_\_\_\_\_

\_\_\_\_\_

\_\_\_\_\_

\_\_\_\_\_

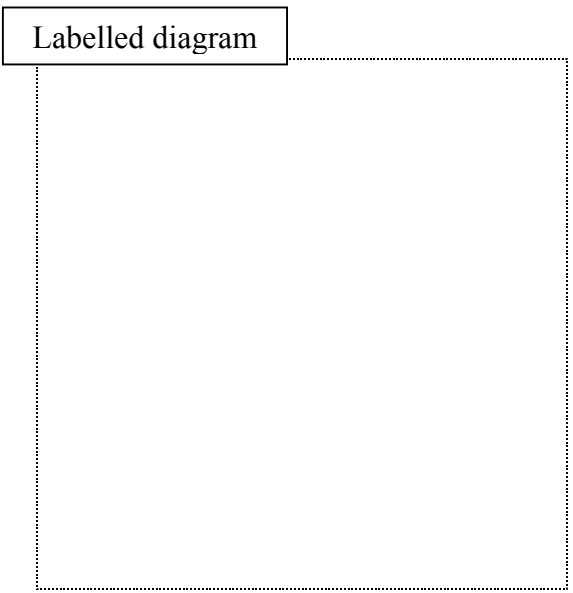

**Question 4**

- (a) The circuit shown was set up to show the **heating effect of an electric current**. When the switch is closed a current flows.

Name the device labelled **X**. \_\_\_\_\_

Name a device that could be connected at **Y** to show that a **current is flowing**. \_\_\_\_\_

What happens the wire when a **current flows**?

\_\_\_\_\_

Name a **household appliance** that uses this effect. \_\_\_\_\_ (3)

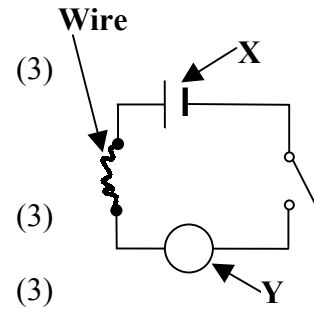

- (b) The diagram shows the inside of a **three-pin plug**.

The **neutral** wire is coloured \_\_\_\_\_ (3)

The **earth** wire is coloured \_\_\_\_\_ (3)

The **fuse** is connected to the \_\_\_\_\_ wire. (3)

The **purpose** of the fuse is to prevent \_\_\_\_\_. (3)

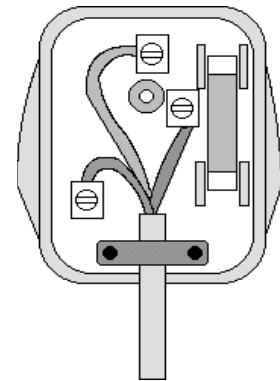

- (c) Describe, with the aid of a labelled diagram, an experiment to **show that light travels in straight lines**. (12)

---



---



---



---



---

Labelled diagram



SECTION C – CHEMISTRY (72 MARKS)

There are **THREE** questions in this Section. Answer any **TWO** of these questions.

Question 5

(a) The diagram shows an atom of **lithium**.

What is the chemical **symbol** for lithium? \_\_\_\_\_ (3)

**Name** the part of the atom labelled **W**. \_\_\_\_\_ (3)

**Where** in the atom would you find an **electron**?

\_\_\_\_\_ (3)

What type of **charge** does a **proton** have?

\_\_\_\_\_ (3)

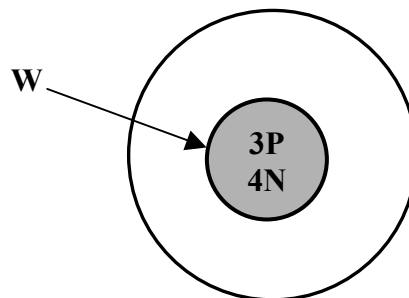

(b) Choose a **term** from the list on the right to complete the sentences below.

**Water** is a good \_\_\_\_\_ (3)

**Salt** \_\_\_\_\_ in water. (3)

**Pure orange juice** is a \_\_\_\_\_ solution. (3)

**Water and orange juice** is a \_\_\_\_\_ solution. (3)

- DILUTE**
- CONCENTRATED**
- SOLVENT**
- DISSOLVES**

(c) Describe, with the aid of a labelled diagram, an experiment to **separate sand and water**. (12)

\_\_\_\_\_

\_\_\_\_\_

\_\_\_\_\_

\_\_\_\_\_

\_\_\_\_\_

\_\_\_\_\_

\_\_\_\_\_

\_\_\_\_\_

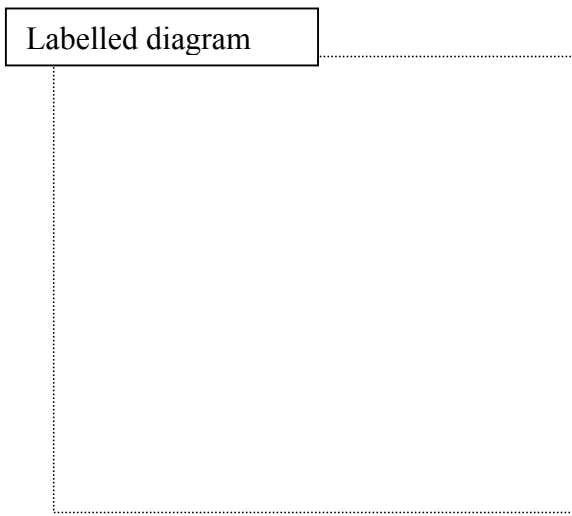

**Question 6**

(a) Choose a **substance** from the list on the right to complete the sentences below.

- \_\_\_\_\_ turns **limewater** milky. (3)
- \_\_\_\_\_ relights a **glowing splint**. (3)
- \_\_\_\_\_ turns blue **litmus** paper red. (3)
- \_\_\_\_\_ turns blue **cobalt chloride** paper pink. (3)

- WATER**
- VINEGAR**
- OXYGEN**
- CARBON DIOXIDE**

(b) **Hard water** is water which will not easily form a lather with soap. There are **two** types of water hardness.

Name **one** type of **water hardness**. (3)

\_\_\_\_\_

Give one **advantage** of hard water. (3)

\_\_\_\_\_

Give one **disadvantage** of hard water. (3)

\_\_\_\_\_

How would you **remove** the hardness from **hard water**? (3)

\_\_\_\_\_

(c) **Carbon dioxide** gas is poured into a jar containing a lighted candle as shown in the diagram.

**What** will happen to the candle? (3)

\_\_\_\_\_

Is carbon dioxide **more dense** or **less dense** than air? (3)

\_\_\_\_\_

Give **two** uses for carbon dioxide. (6)

1 \_\_\_\_\_

2 \_\_\_\_\_

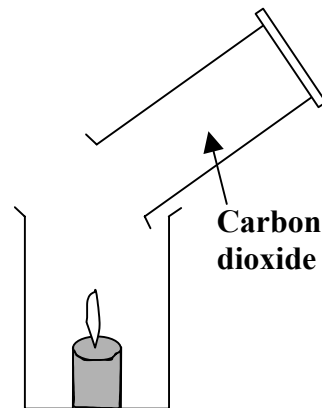

**Question 7**

(a) Match a **metal** from the list on the right with its **use** given below.

- Used in **electrical** wires \_\_\_\_\_ (3)
- Used in **thermometers** \_\_\_\_\_ (3)
- Used in **drink cans** \_\_\_\_\_ (3)
- Used to make **jewellery** \_\_\_\_\_ (3)

- SILVER**

**MERCURY**

**COPPER**

**ALUMINIUM**

(b) Choose **two metals** from the list of elements on the right.

- 1 \_\_\_\_\_ (3)
- 2 \_\_\_\_\_ (3)

- CHLORINE**

**POTASSIUM**

**MAGNESIUM**

**NEON**

Metals are often used to make **alloys**.

Name **one** alloy. \_\_\_\_\_ (3)

Give one use for the **alloy** you have named. (3)

\_\_\_\_\_

(c) The diagram shows an experiment that can be carried out in the laboratory to **show electroplating**.

What is meant by **electroplating**?

\_\_\_\_\_

\_\_\_\_\_

What happens to the **copper**?

\_\_\_\_\_

Name **one** kitchen utensil that is electroplated.

\_\_\_\_\_

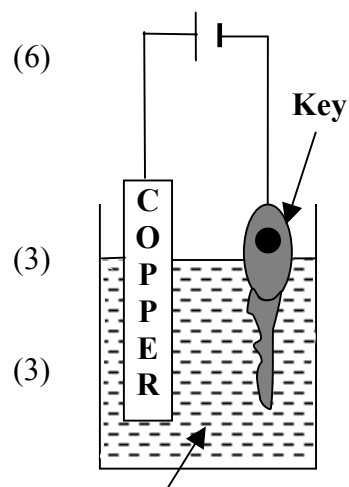

**Copper sulphate solution**

**SECTION D – BIOLOGY (72 MARKS)**

**There are THREE questions in this Section. Answer any TWO of these questions.**

**Question 8**

(a) The diagram shows the **structure** of a tooth.

Name part **A**. \_\_\_\_\_ (3)

Name the **mineral** needed by your teeth. (3)

\_\_\_\_\_

What is **plaque**? (3)

\_\_\_\_\_

What would you use to **show** up the plaque on your teeth? (3)

\_\_\_\_\_

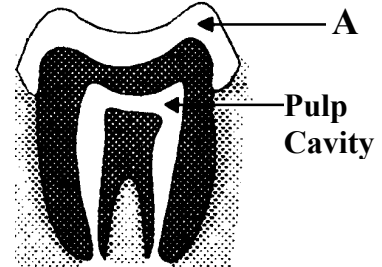

(b) The diagram shows part of the **human digestive system**.

Name the organ **A**. \_\_\_\_\_ (3)

Name the organ **B**. \_\_\_\_\_ (3)

What is the **function** of **A**? (3)

\_\_\_\_\_

What **liquid** is reabsorbed in **B**? (3)

\_\_\_\_\_

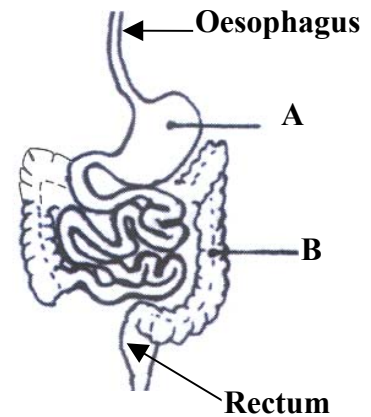

(c) The diagram shows a model of the **breathing system**.

Which **part** of the body is represented by **A**? (3)

\_\_\_\_\_

Which **part** of the body is represented by **B**? (3)

\_\_\_\_\_

Which **part** of the body is represented by **C**? (3)

\_\_\_\_\_

What happens when the **rubber sheet** is pulled down? (3)

\_\_\_\_\_

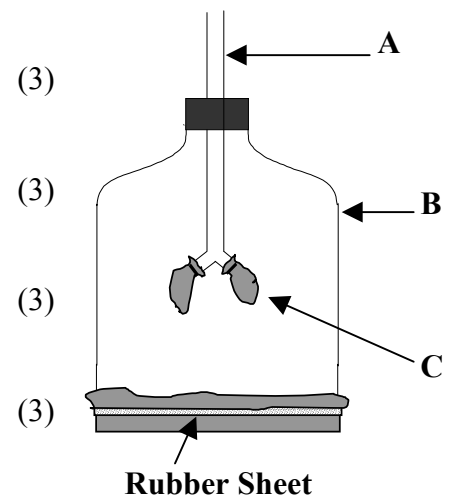

**Question 9**

(a) Choose a **word** from the list on the right to **complete** the table below.

(12)

LIVING	NON-LIVING

- STONE
- FROG
- DAISY
- WIND

(b) The **flower** is the reproductive part of the plant.

The \_\_\_\_\_ **protects** the flower before it opens. (3)

The \_\_\_\_\_ are produced in the **carpel**. (3)

The part of the flower that **attracts insects** is the \_\_\_\_\_. (3)

The **stamen** releases \_\_\_\_\_. (3)

(c) The diagram shows a piece of apparatus that was **used to collect animals**.

**Name** the piece of apparatus. \_\_\_\_\_ (3)

Why is the jar covered with a **lid**? (3)

\_\_\_\_\_

Name **two** animals you might find in the jar. (6)

1 \_\_\_\_\_

2 \_\_\_\_\_

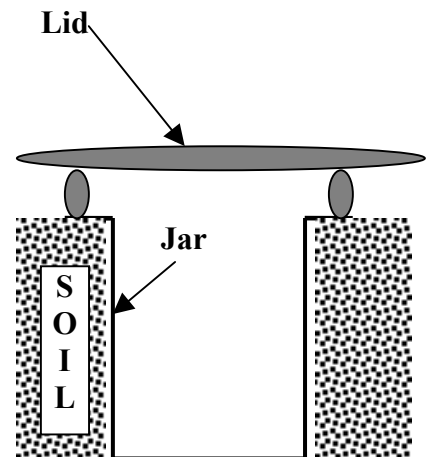

**Question 10**

(a) The diagram shows an **onion cell**.

Name the **instrument** used in the laboratory to examine an onion cell. (3)

\_\_\_\_\_ (3)  
Name the part labelled **A**.

\_\_\_\_\_ (3)  
Name the part labelled **B**.

\_\_\_\_\_ (3)  
Name **one** other part of the onion cell.

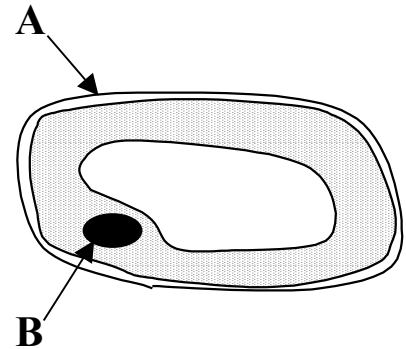

(b) The diagram shows an experiment used to study **transport of water in plants**.

What happens to the **level** of water in the tube after a few days? (3)

\_\_\_\_\_ (3)  
Why is **oil** placed on the water?

\_\_\_\_\_ (3)  
Which **part** of the plant takes in water?

\_\_\_\_\_ (3)  
What is the function of the **leaf** of the plant?

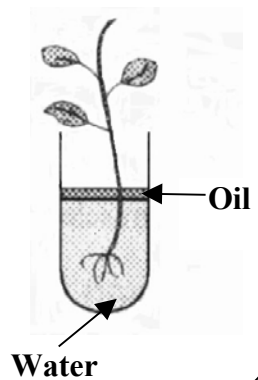

(c) Describe, with the aid of a labelled diagram, an experiment to **measure the amount of air in a soil**. (12)

\_\_\_\_\_  
\_\_\_\_\_  
\_\_\_\_\_  
\_\_\_\_\_  
\_\_\_\_\_  
\_\_\_\_\_  
\_\_\_\_\_  
\_\_\_\_\_

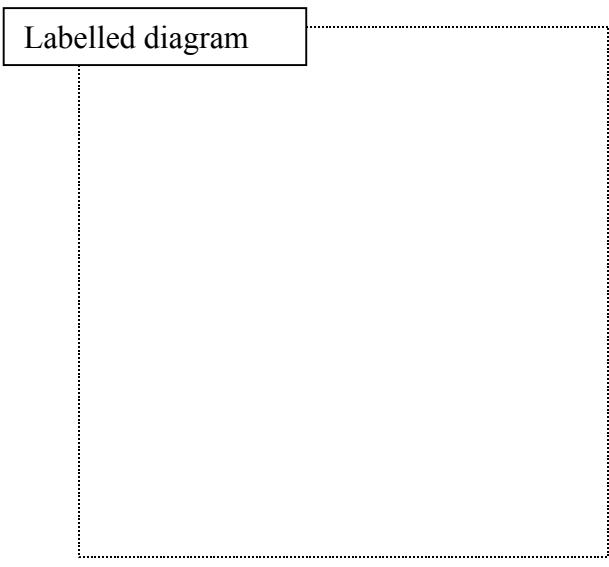

**SECTION E – APPLIED SCIENCE (72 MARKS)**

**There are SIX questions in this Section. Answer any TWO of these questions.**

**Question 11 - Earth Science**

(a) Choose a **word** from the list on the right to complete the sentences below.

Our **galaxy**, the Milky Way, contains about 100 000 \_\_\_\_\_ . (3)

A body in **orbit** around a planet is called a \_\_\_\_\_ . (3)

Large amounts of \_\_\_\_\_ **energy** are produced  
by the Sun. (3)

The **time** taken by Earth to orbit the Sun is a \_\_\_\_\_ . (3)

**LIGHT**  
**STARS**  
**YEAR**  
**SATELLITE**

(b) The diagram shows an instrument used in **weather** recording.

**Name** the instrument shown. \_\_\_\_\_ (3)

What does this instrument **measure**? \_\_\_\_\_ (3)

What instrument is used to measure **rainfall**? \_\_\_\_\_ (3)

What does an **anemometer** measure? \_\_\_\_\_ (3)



(c) Describe, with the aid of a labelled diagram, an experiment to show **the effect of wind on the rate of evaporation of water**. (12)

\_\_\_\_\_

\_\_\_\_\_

\_\_\_\_\_

\_\_\_\_\_

\_\_\_\_\_

\_\_\_\_\_

\_\_\_\_\_

\_\_\_\_\_

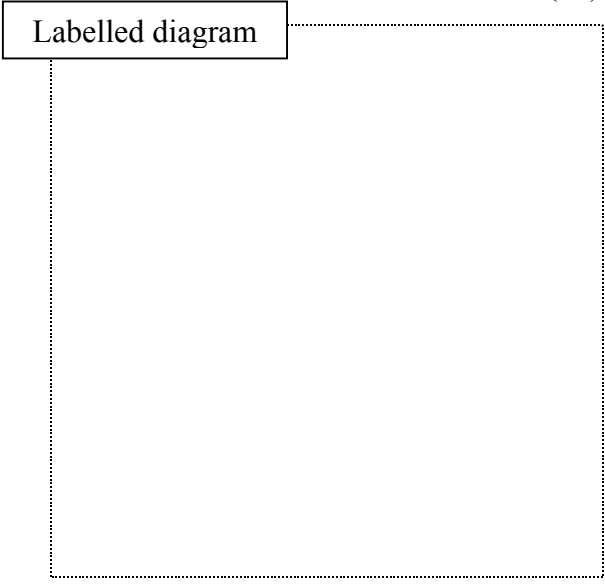

**Question 12 - Horticulture**

(a) What is **germination**? (3)

\_\_\_\_\_

Name **two** conditions all seeds need to germinate. (6)

1 \_\_\_\_\_ 2 \_\_\_\_\_

Why do plants need **light** to grow? (3)

\_\_\_\_\_

(b) What is **hydroponics**? (6)

\_\_\_\_\_

Give **one** advantage of using a compost to grow plants. (3)

\_\_\_\_\_

What happens to a plant if it gets too little **water**? (3)

\_\_\_\_\_

(c) Describe, with the aid of a labelled diagram, the **life cycle of a common garden pest**. (12)

\_\_\_\_\_  
\_\_\_\_\_  
\_\_\_\_\_  
\_\_\_\_\_  
\_\_\_\_\_  
\_\_\_\_\_  
\_\_\_\_\_  
\_\_\_\_\_

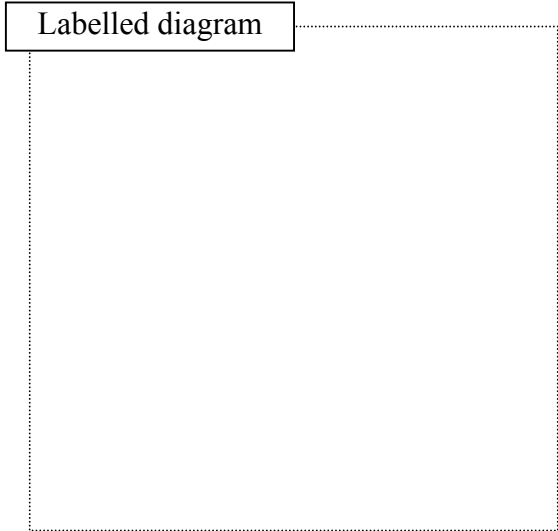





**A - PLASTICS**

- (i) Give **one** use for plastics in the home. \_\_\_\_\_ (3)
- (ii) What are most plastics **made** from? \_\_\_\_\_ (3)
- (iii) Describe, with the aid of a labelled diagram, an experiment to **compare the flexibility of two plastics**. (12)

---

---

---

---

---

---

---

---

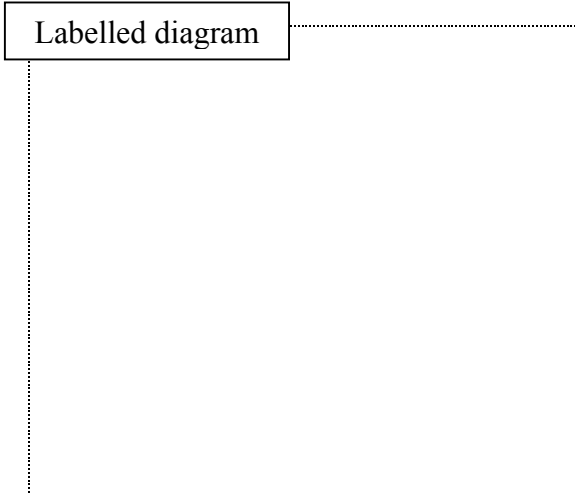

**B - TEXTILES**

- (i) What is meant by **flame-proofing** a fabric? \_\_\_\_\_ (6)
- (ii) Describe, with the aid of a labelled diagram, an experiment to **compare the absorbency of two textiles**. (12)

---

---

---

---

---

---

---

---

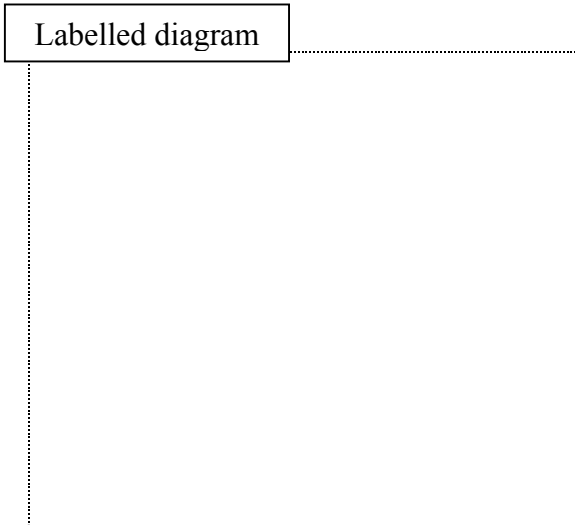

**C - METALS**

- (i) Name **one** metal that is found **free in nature**. \_\_\_\_\_ (3)
- (ii) Name **one** metal that is found as an **ore**. \_\_\_\_\_ (3)
- (iii) Describe, with the aid of a labelled diagram, an experiment to **compare the hardness of two metals**. (12)

---

---

---

---

---

---

---

---

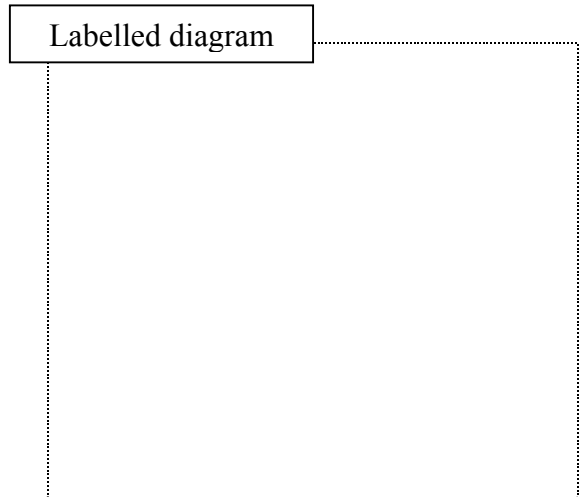

**D - TIMBER**

- (i) Name a **hardwood**. \_\_\_\_\_ (3)
- (ii) Give **one use** for the hardwood you have named. \_\_\_\_\_ (3)
- (iii) Describe, with the aid of a labelled diagram, an experiment to **compare the bending strength of two pieces of timber**. (12)

---

---

---

---

---

---

---

---

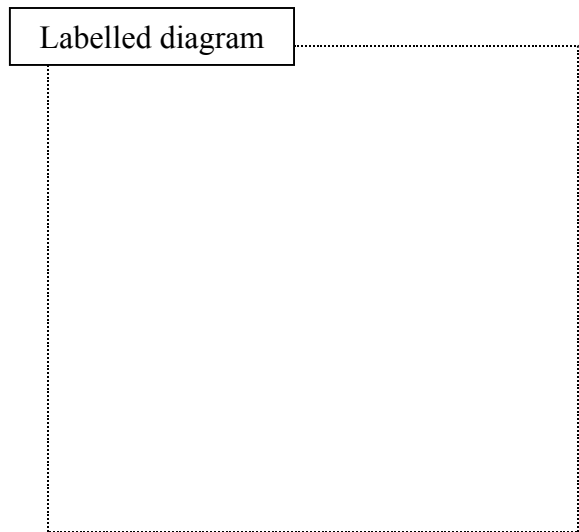

**Question 14 - Food**

(a) Choose a **food** from the list on the right that is needed by the body for

- strong bones \_\_\_\_\_ (3)
- energy \_\_\_\_\_ (3)
- vitamin C \_\_\_\_\_ (3)
- body building \_\_\_\_\_ (3)

- LEAN MEAT**
- ORANGE JUICE**
- CALCIUM**
- SUGAR**

(b) Many of the foods we eat are **processed** before we eat them.

A **food** can be **processed** by \_\_\_\_\_ (3)

Name **two** foods made from processed milk.

1 \_\_\_\_\_ 2 \_\_\_\_\_ (6)

Name **one** other processed food. \_\_\_\_\_ (3)

(c) Describe, with the aid of a labelled diagram, how you would **use some freshly cut grass to make silage**. (12)

---

---

---

---

---

---

---

---

---

---

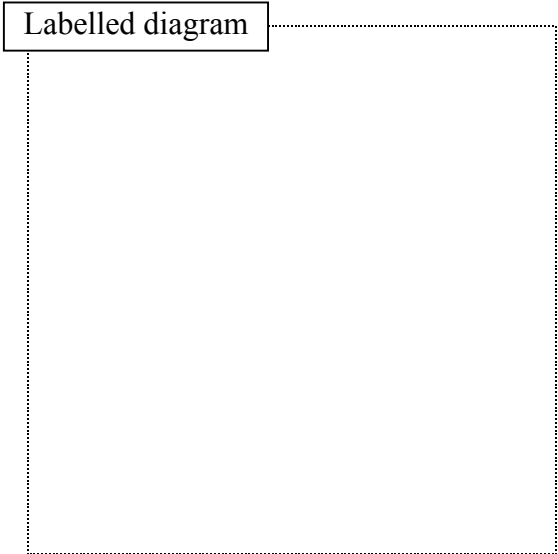

**Question 15 - Electronics**

(a) Match an **electronic component** from the list on the right with each of the following symbols.



\_\_\_\_\_

(3)



\_\_\_\_\_

(3)

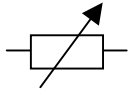

\_\_\_\_\_

(3)

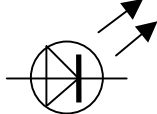

\_\_\_\_\_

(3)

**VARIABLE RESISTOR**

**LED**

**AMMETER**

**VOLTMETER**

(b) The diagram shows an **LDR** connected in a simple circuit.

An **LDR** is a Light \_\_\_\_\_ Resistor. (3)

The **resistance** of the LDR **increases** in \_\_\_\_\_ light. (3)

The **resistance** of the LDR **decreases** in \_\_\_\_\_ light. (3)

Give **one** everyday use of an LDR. (3)

\_\_\_\_\_

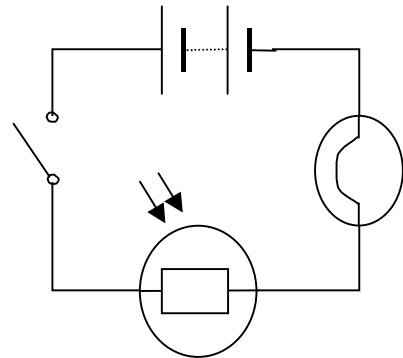

(c) Draw a circuit diagram to show a **battery, a resistor and two LEDs**. The **LEDs** should be **connected in parallel so that both will light**. (12)

Circuit diagram

**Question 16 - Energy Conversions**

(a) Choose a **form** of energy from the list on the right to complete the sentences below.

**Moving** air has \_\_\_\_\_ energy. (3)

A bow **about** to fire an arrow has \_\_\_\_\_ energy. (3)

A **solar** cell uses \_\_\_\_\_ energy. (3)

When a guitar string **vibrates** it produces \_\_\_\_\_ energy. (3)

- |                  |
|------------------|
| <b>LIGHT</b>     |
| <b>KINETIC</b>   |
| <b>SOUND</b>     |
| <b>POTENTIAL</b> |

(b) The diagram shows the parts of an **electromagnet**.

What **metal** is used to make the core? \_\_\_\_\_ (3)

How would you know that an **electromagnet is formed** when

the switch is closed? \_\_\_\_\_

\_\_\_\_\_ (3)

The **energy change** which takes place in an electromagnet

is \_\_\_\_\_ to magnetic. (3)

Give **one** everyday use of an electromagnet. (3)

\_\_\_\_\_

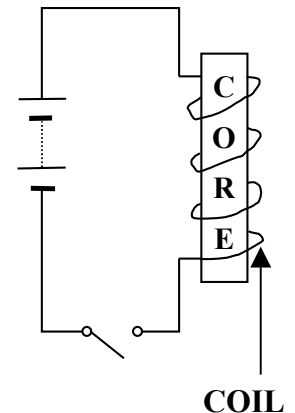

(c) Describe, with the aid of a labelled diagram, an experiment to **show that energy can be released from food, e.g., peanuts.** (12)

\_\_\_\_\_

\_\_\_\_\_

\_\_\_\_\_

\_\_\_\_\_

\_\_\_\_\_

\_\_\_\_\_

\_\_\_\_\_

\_\_\_\_\_

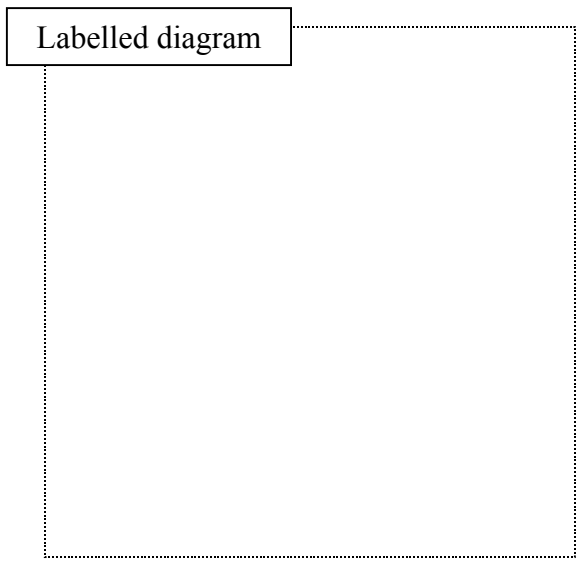



**EXTRA WORKSPACE**

Indicate **clearly** the number of the question(s) you are answering.

A large rectangular area with rounded corners, containing 25 horizontal lines for writing.