



*Leaving Certificate Examination 2006*

***Technical Drawing***  
***Paper II(B) – Ordinary Level***  
***(Building Applications)***

*(200 Marks)*

***Friday 16 June***  
***Afternoon, 2.00 – 5.00***

- (a) Answer **four** questions.*
- (b) All questions carry equal marks.*
- (c) Construction lines must be shown on all solutions.*
- (d) Write the number of the question distinctly on the answer paper.*
- (e) Work on one side of the paper only.*
- (f) All dimensions on the question paper are given in metres or millimetres.*
- (g) First or third angle projection may be used.*

1. Fig. 1 shows the outline plan and elevation of a building. A pictorial view of the structure is also shown.

Draw the given plan and make a perspective drawing of the building when the position of the spectator is 10m from the corner A, the picture plane is touching the corner A, and the horizon line is 2.5m above the ground line.

Scale 1 : 100

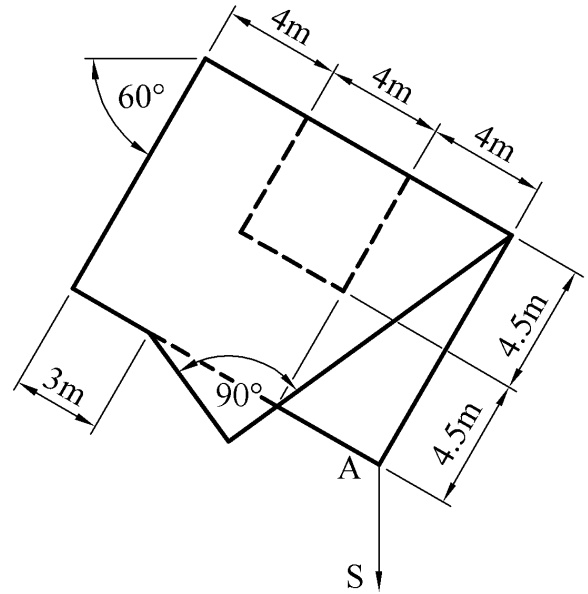
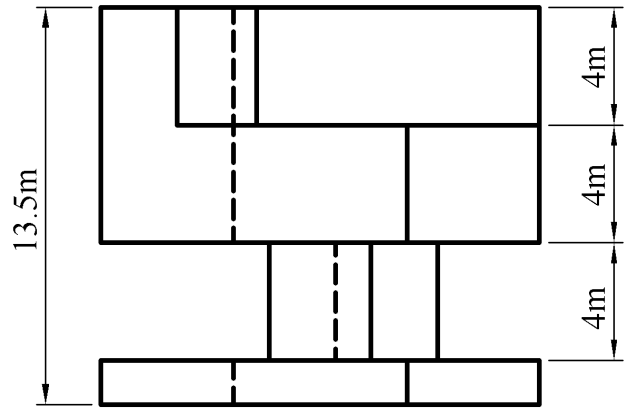
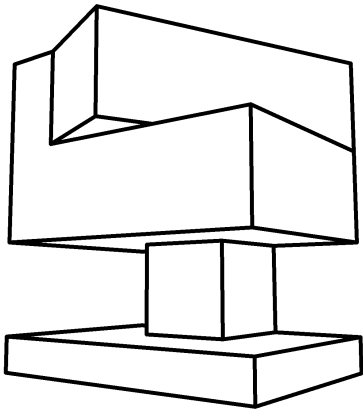

Fig. 1

2. Fig. 2 shows the outline plan and elevation of a roof.

Surfaces A and B have a pitch of  $50^\circ$ .  
Surfaces C and D have a pitch of  $45^\circ$ .

- (a) Draw the given plan and elevation of the roof.
- (b) Develop the surfaces  $S_1$  and  $S_2$ .
- (c) Find the dihedral angle between the roof surfaces A and D.

Scale 1 : 100

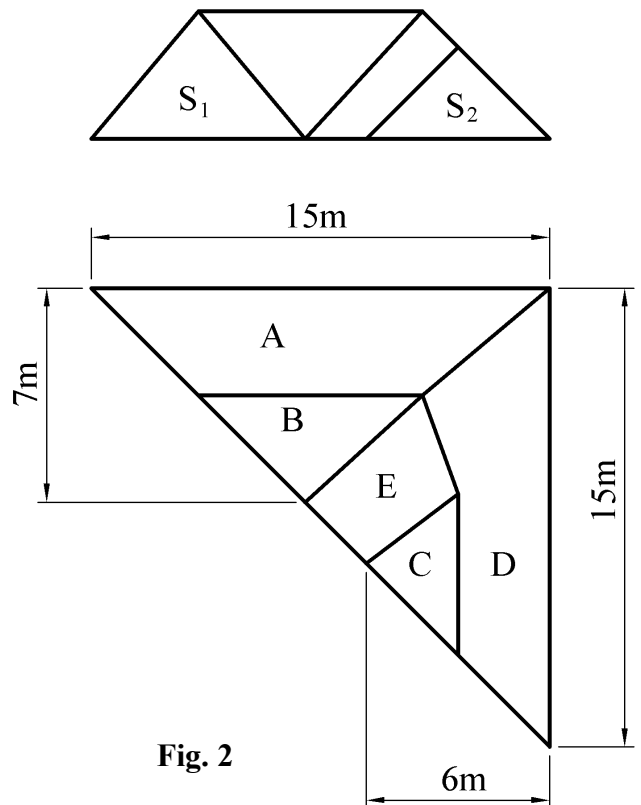
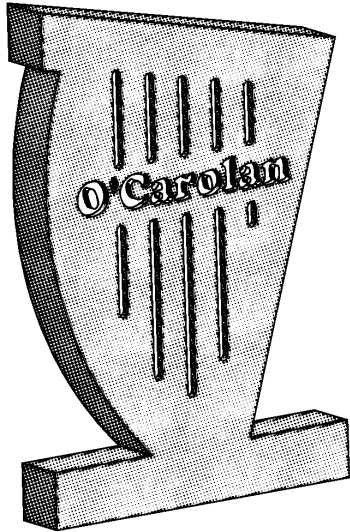

Fig. 2

3. Fig. 3 shows the plan, elevation and pictorial view of a monument to commemorate a famous Irish musician.

Draw the given plan and elevation and determine the shadows cast in plan when the direction of light is as shown.

(Omit the engraving, which is shown in the pictorial view, from your drawing).



Scale 1 : 100

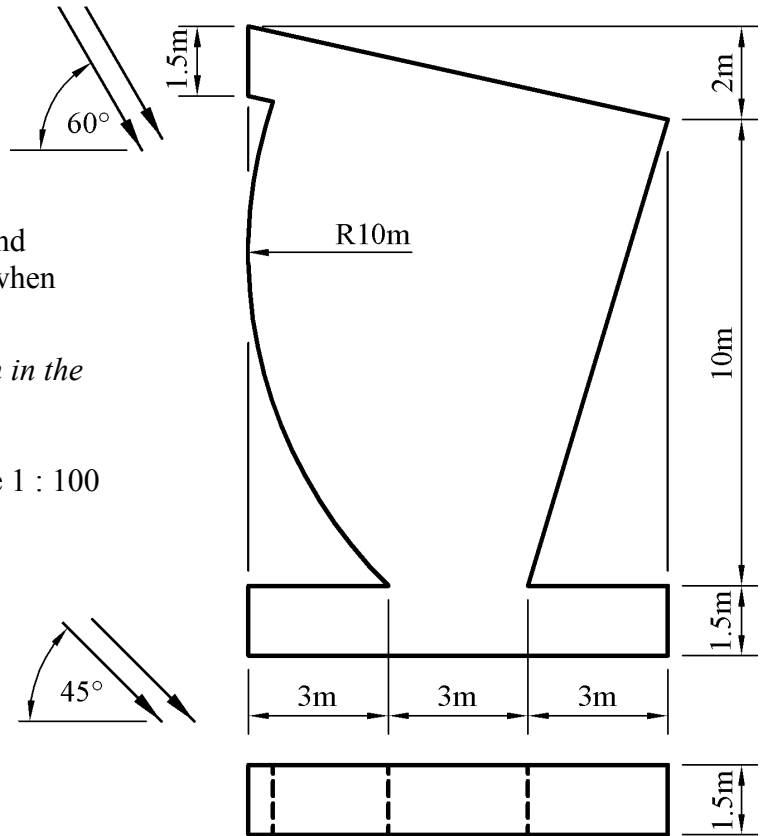

Fig. 3

4. Fig. 4 shows the outline plan of part of a roof over a football stadium. It consists of two adjoining hyperbolic paraboloid surfaces ABCD and ADEF. The corners A, B and F are 25m above ground level. Corners C and E are 50m above ground level and the corner D is 100m above ground level.

- Draw the given plan of the roof and project an elevation.
- Project an end elevation of the roof.
- Determine the true shape of the section S-S through the roof surface.

Scale 1 : 1000

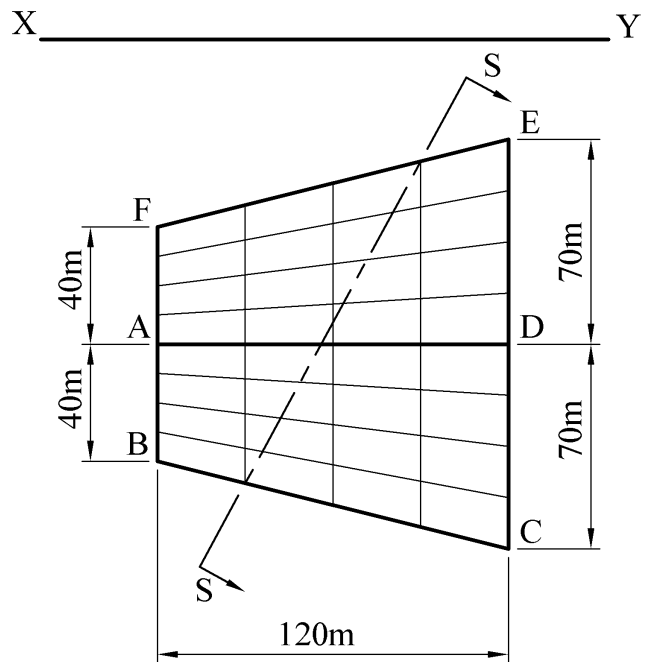

Fig. 4

5. Fig. 5 shows the elevation and end elevation of a recycling bank.

Draw the given views and draw an isometric view of the recycling bank.

(Omit the logo from your drawing)

Scale 1 : 10

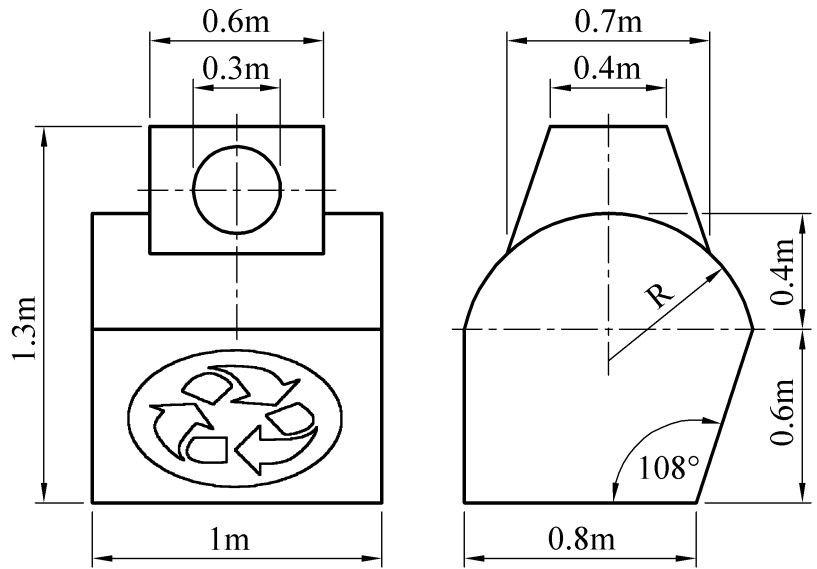

Fig. 5

6. Fig. 6 shows the outline plan and elevation of a hotel building situated on the coast. The design of the building is in the shape of the crest of a wave. A pictorial view is also given.

The outline curves are semi parabolic in elevation. The vertices for the parabolas are located at V and V<sub>1</sub>.

- (a) Draw the given plan and elevation.
- (b) Project an end elevation of the building.

Scale 1 : 100

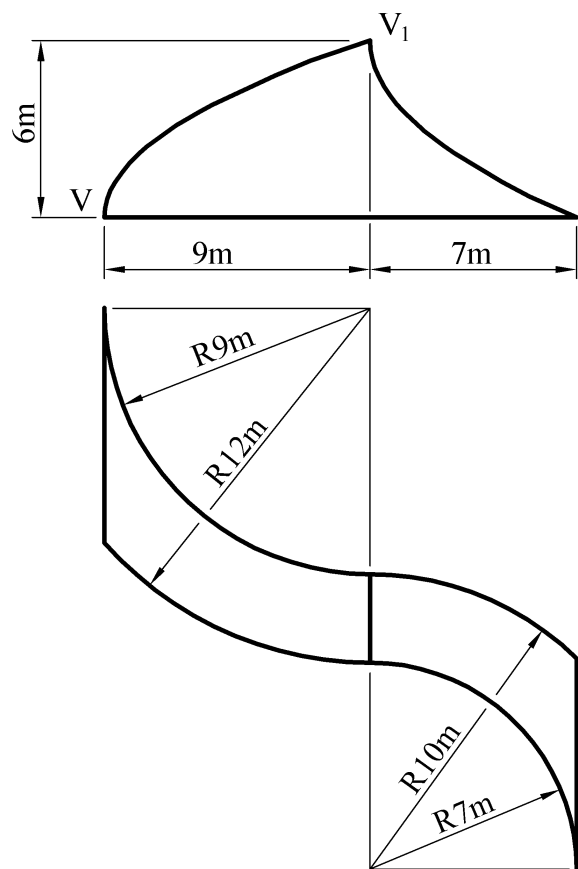
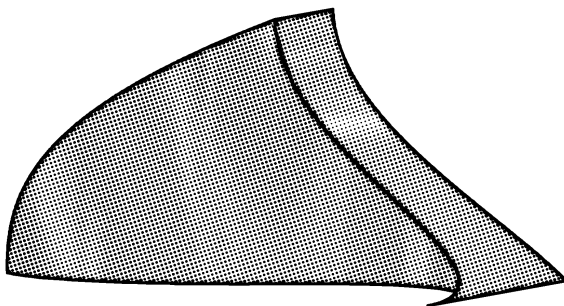

Fig. 6

7. The accompanying drawing shows ground contours at ten-metre vertical intervals on a map.
- (a) On the drawing supplied, draw a vertical section (profile) on the line DE.
  - (b) A, B and C are outcrop points on the surface of a stratum of ore.  
Determine the dip and strike of the stratum.
  - (c) An electricity generating wind turbine, which measures 20m in height, is to be erected at a point along the line FG.  
Planning permission requires that the structure must not break the skyline, when viewed from the ground at G.  
Determine the highest possible location for the turbine.



**Coimisiún na Scrúduithe Stáit**  
*State Examinations Commission*  
**Scrúdú Ardteistiméireachta 2006**  
*Leaving Certificate Examination 2006*

**Scrúduimhir:**  
*Examination Number:*

