



**Coimisiún na Scrúduithe Stáit
State Examinations Commission**

Leaving Certificate Examination, 2003

***Technical Drawing
Paper 1 – Ordinary Level
(Plane and Solid Geometry)***

(200 Marks)

***Thursday 12 June
Afternoon, 2.00 to 5.00***

- (a) Answer **four** questions.*
- (b) All questions carry equal marks.*
- (c) Construction lines must be shown on all solutions.*
- (d) Write the number of the question distinctly on the answer paper.*
- (e) All dimensions on the question paper are given in metres or millimetres.*
- (f) First or third angle projection may be used.*

1. An isometric view of a shaped solid is shown in Fig. 1.
 - (a) Draw an elevation of the solid looking in the direction of the arrow.
 - (b) Project a plan from the elevation.
 - (c) Project a new elevation of the solid from the plan, which will show the true shape of the surface A.

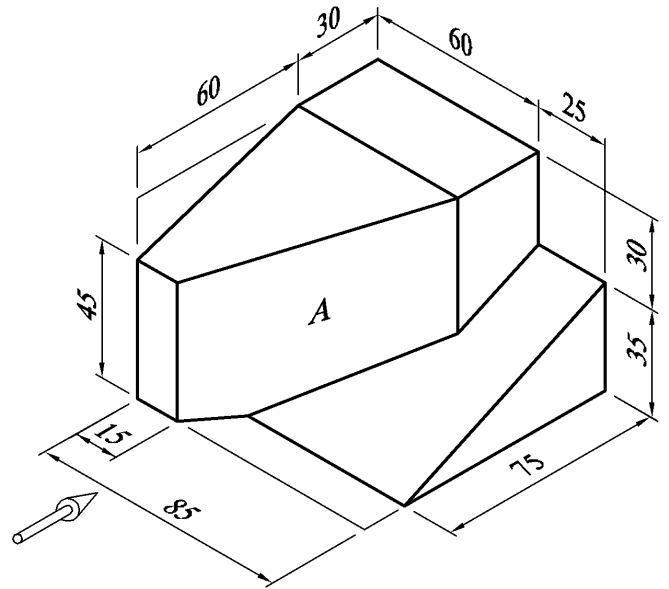

Fig. 1

2. Fig. 2 shows a quadrilateral ABCD. The sides of the triangle ABC are in a ratio of 3:5:6. The triangle ACD is equal in area to the triangle ABC.

- (a) Draw the given figure showing clearly how the points A and D are obtained.
- (b) Draw a square, which shall have 0.75 times the area of the figure ABCD.

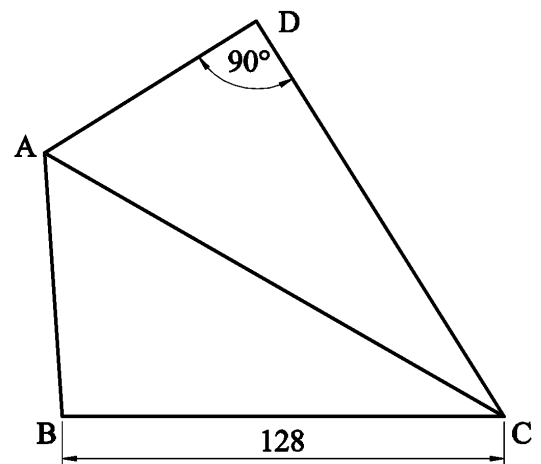

Fig. 2

3. Fig. 3 shows the plan of a cylinder A and a cone B which are in contact with each other. The cone has an altitude of 70mm. Both solids rest on the horizontal plane. The plan of a point P on the surface of the cone is also shown.

- (a) Draw the plan and elevation of both solids and show the position of the point P in the elevation.
- (b) Draw the plan and elevation of a sphere, having a diameter of 40mm, which shall be in contact with the given cone at the point P.

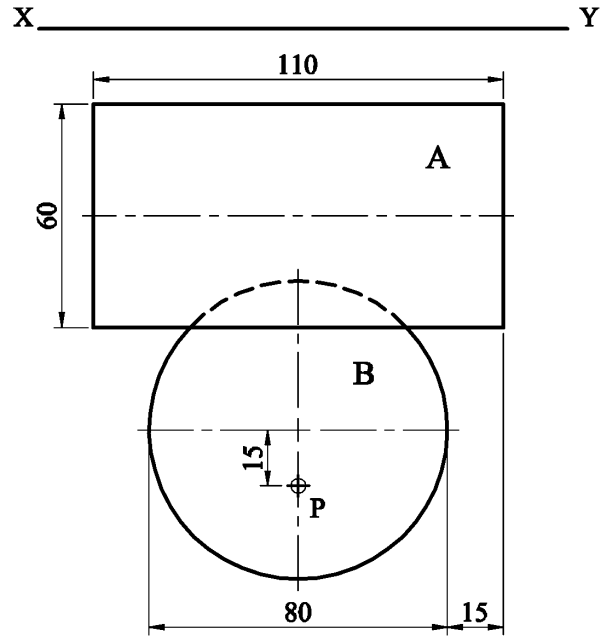

Fig. 3

4. Fig. 4 shows two circles A and B, which intersect at point P.

Circle A rolls clockwise along the line CD until the point P reaches the line CD.
 Circle B rolls anti-clockwise along the line CD until the point P reaches the line CD.

Plot the locus of point P for both movements.

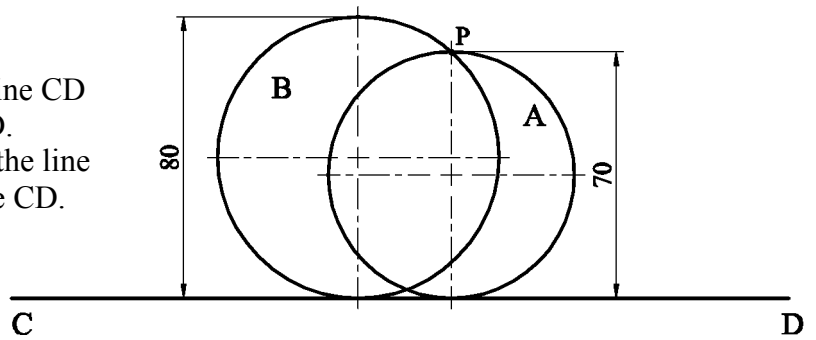

Fig. 4

5. The elevation and plan of a solid cut by an oblique plane VTH are shown in Fig. 5.

- (a) Draw the plan and elevation of the solid when it is cut by the oblique plane VTH.
- (b) Draw the true shape of the cut surface of the solid.

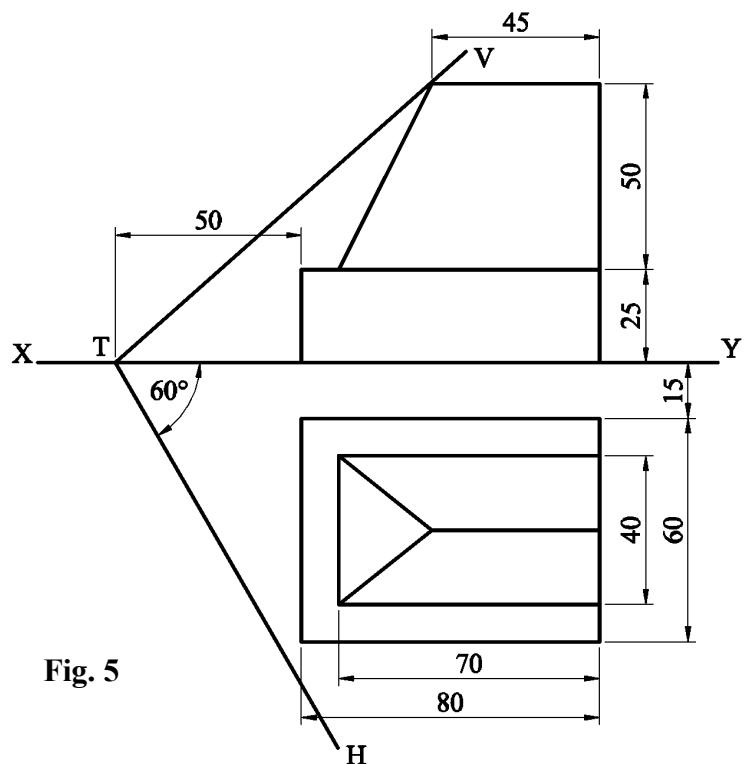

Fig. 5

6. (a) The major axis of an ellipse is 130mm long and its focal points are 100mm apart. Locate the minor axis and draw the ellipse.

- (b) Fig. 6 shows the axis, directrix DD_1 and a point P on the curve of a hyperbola. The eccentricity of the curve is 1.5.

Locate the focus and vertex and draw a portion of the curve which passes through the given point P.

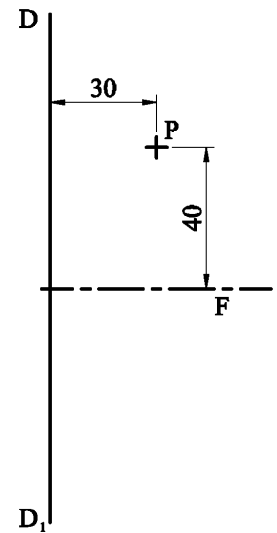

Fig. 6

7. Fig. 7 shows the elevation and plan of an equilateral triangular based prism, which is intersected by another triangular prism.

Draw the plan, elevation and end elevation of the solids showing all lines of interpenetration.

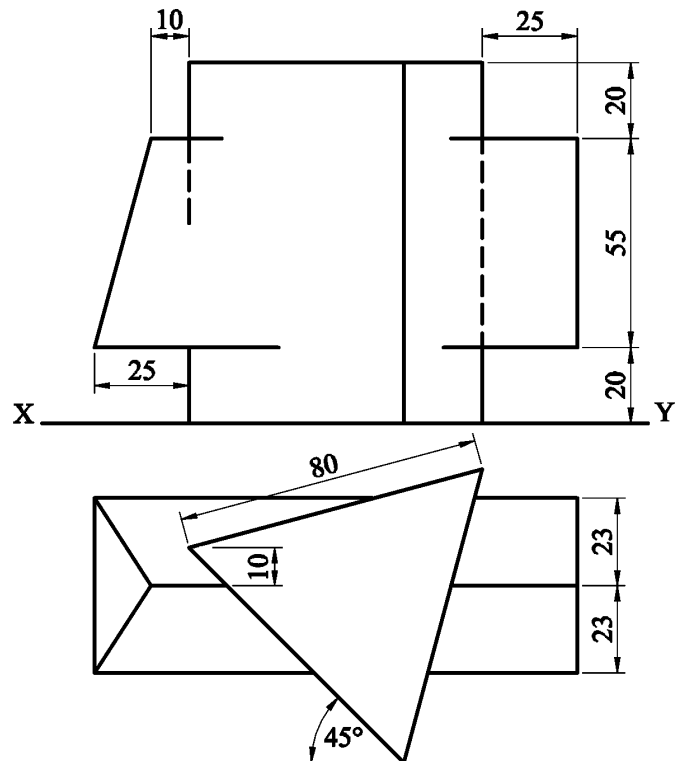

Fig. 7

BLANK PAGE

BLANK PAGE