

AN ROINN OIDEACHAIS  
LEAVING CERTIFICATE EXAMINATION, 1964.

ART AND DRAWING.

MECHANICAL DRAWING AND DESIGN.  
PASS.

FRIDAY, 12th June - Afternoon, 1.30 - 3.30.

INSTRUCTIONS.

- Candidates may take Section I or II but not both.
- The use of drawing instruments and tracing paper is allowed. Materials such as potatoes, corks, sponges, twigs, rags, pieces of cardboard, may also be used.
- The number of the question must be distinctly marked by the side of the answer.
- Questions marked (\*) have accompanying diagrams.

SECTION I.—(100 marks.)

ONE QUESTION ONLY TO BE ATTEMPTED.

- Design a poster to advertise one of the following:— (a) An Art Exhibition, (b) A Pantomime, (c) A Flower Shop. Appropriate lettering should be included in the design.
- Design a cover for a book on Irish History, size 10 inches by 8 inches.
- Design an all-over pattern for a summer frock material, or curtains. Complete as much of the pattern as will show the general effect.
- Make a design to suit a semi-circular tea cosy of 10 inches diameter. The design should be suitable for fabric-printing or embroidery.

5. Write out the following verses, using lettering pens, on a sheet of paper not less than 10 inches by 8 inches.

FROLIC.

The children were shouting together  
And racing along the sands,  
A glimmer of dancing shadows,  
A dovelike flutter of hands.

The stars were shouting in heaven,  
The sun was chasing the moon;  
The game was the same as the childrens'  
They danced to the self-same tune.

A.E.

SECTION II.—(100 marks.)

THREE QUESTIONS ONLY TO BE ATTEMPTED.

(All questions carry equal marks.)

\* 1. The front and side elevations of a cross are shown in the diagram. The base of the cross is square. Draw the front elevation and plan of the cross according to the given dimensions.

\* 2. Draw the pattern shown according to the dimensions given. Show construction lines.

\* 3. Draw a pattern to fill the shape shown in the diagram, according to the dimensions given.

\* 4. The diagram shows the front elevation (A), plan (B), and side elevation (C), of a bracket. Make a free-hand pictorial drawing of the bracket, approximately 4 inches in height.

5. Draw a design for a panel in the form of a regular pentagon of 4 inch side. The design is to be based on geometric ornament and should be suitable for some craft.

(For diagrams ① and ②, see over.)

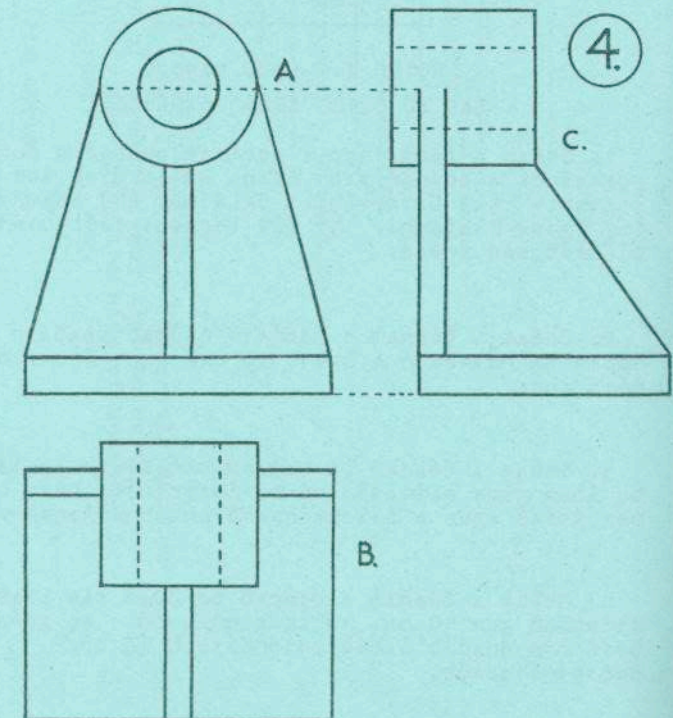
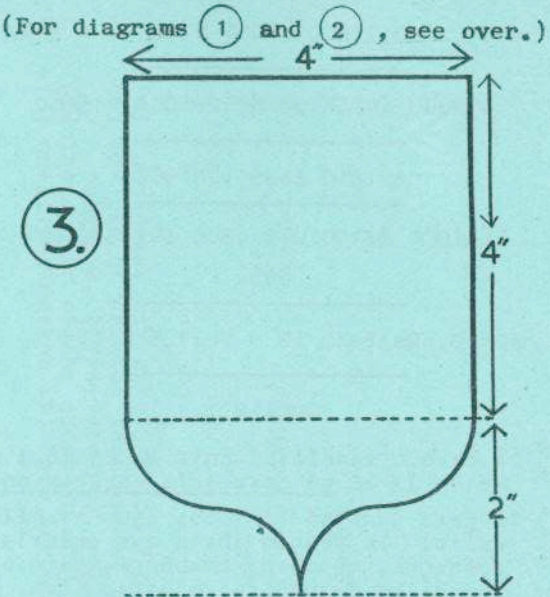

Α Η Ρ Ο Ι Η Η Ο Ι Θ Θ Α Ξ Α Ι Σ.

SCRÚBÚ ARΘΘΕΙΣΤΗΜΕΙΡΕΑΘΤΑ, 1964.

ΘΑΛΑΪΝ ΑΣΥΣ ΙΝΗΘΟΤ

ΙΝΗΘΟΤ ΗΘΕΙΤΗΝΙΝ ΑΣΥΣ ΣΡΕΑΣΘΟΡΙΥΙ.

PAS.

ΘΕ ΗΑΘΙΗΘ, ΗΕΙΘΕΑΗ 12 - ΤΡΑΪΘΝΗΑ 1.30 - 3.30.

ΘΗΑΙΡΛΙ.

- (Α) ΊΣ ΘΕΑΘ Δ'ΙΑΡΡΕΘΟΡΙΪ ΤΟΞΑ ΑΣ ΡΟΙΗΗ Ι ΗΘ ΑΣ ΡΟΙΗΗ ΙΙ ΑΘ ΗΪ ΘΕΑΘ ΤΟΞΑ ΑΣΤΥ ΑΡΑΘΗ.
- (β) ΊΣ ΘΕΑΘ ΥΙΡΛΙΣΪ ΙΝΗΘΟΤΑ ΑΣΥΣ ΡΙΑΗΘΑΪΡΕΑΡ Α ΎΣΑΪΘ. ΊΣ ΡΕΪΘΥΙΡ ΑΪΘΑΥΡ ΗΑΡ ΨΡΑΪΑΪ, ΘΟΡΘΑΗΗΑ, ΗΥΣΘΑΪΗ, ΘΡΑΘΘΟΞΑ, ΘΕΥΡΤΕΑΘΑ ΡΪΘΑΪ ΘΕ ΘΑΥΡΤΕΛΑΥΡ, Δ'ΎΣΑΪΘ ΛΟΙΣ.
- (γ) ΥΙΗΥΙΡ ΗΑ ΘΕΙΣΤΕ Α SCRΪΘΘ ΊΘΟ ΣΟΙΛΕΪΡ ΛΘ ΗΑΪΣ ΑΗ ΦΡΕΑΞΡΑ Α ΞΑΘΑΗΗ ΛΘΪ.
- (δ) ΤΑ ΛΕΑΡΑΪΘΪ ΡΑΡΑ ΗΑ ΘΕΙΣΤΕΑΗΗΑ Α ΘΨΥΪΛ ΡΕΪΛΤΪΗ (\*) ΡΟΜΠΥ.

ΡΟΙΗΗ Ι.—(100 ΗΑΡΘ.)

ΞΑΗ ΑΘ ΘΕΪΣΤ ΑΗΑΪΗ Α ΘΘΑΗΑΗ.

1. ΞΡΕΑΣ Α ΘΑΡΡΑΪΗΞΤ Ί ΞΘΗΑΥΡ ΡΟΞΑΘΪΥΡ ΘΥΗ ΡΘΞΡΑΪΘΘΤ Α ΘΘΑΗΑΗ ΡΑΘΪ ΘΘΑΗΗ ΑΗΑΪΗ ΔΪΘΘ ΣΘΟ Α ΛΘΑΗΑΣ:- (Α) ΤΑΪΣΡΕΑΗΤΑΣ ΘΑΛΑΪΗΘ, (β) ΞΕΑΗΑΥΡΕΑΘΤ, (γ) ΣΪΘΡΑ ΘΪΛΑΞΑΗΗΑ. ΗΪ ΗΘΡ ΛΙΤΡΘΘΥΡΕΑΘΤ ΟΥΡΥΗΑΘ Δ'ΎΣΑΪΘ ΞΑΗ ΞΡΕΑΣ.

2. ΞΡΕΑΣ Α ΘΘΑΗΑΗ Ί ΞΘΗΑΥΡ ΘΪΪΥΔΑΘ ΛΘΑΘΑΥΡ ΑΡ ΣΤΑΥΡ ΗΑ ΗΘΪΥΡΘΑΗΗ Α ΘΨΥΪΛ 10 ΟΡ. ΡΑΘΪ 8 ΟΡ. ΘΘ ΗΘΕΪΘ ΑΗΗ.

3. ΞΡΕΑΣ Α ΘΘΑΗΑΗ ΛΘ ΗΑΞΑΪΘ ΣΑΗΛΑΘΑΪΣ ΙΟΜΛΑΪΗ ΘΘ ΑΪΘΑΡ ΞΥΗΑ ΣΑΗΡΑΪΘ, ΗΘ ΘΘ ΘΥΑΥΡΤΪΗΪ. ΘΘΑΗ ΟΥΡΕΑΘ ΘΘΗ ΞΡΕΑΣ ΑΣΥΣ Α ΘΑΪΣΡΕΑΗΡΑΪΘ ΑΗ ΘΥΗΑ ΞΪΗΘΕΑΡΑΛΤΑ.

4. ΞΡΕΑΣ Α ΘΘΑΗΑΗ Α ΟΥΡΨΥΘ ΘΘ ΡΪΥΙΘ ΤΑΘ ΛΘΔΘ-ΘΥΟΡΘΛΑΘ ΞΥΡ 10 ΟΡ. ΊΣ ΤΡΑΞΘΗΑΣ ΘΘ. ΑΗ ΞΡΕΑΣ Α ΘΕΪΘ ΟΥΡΥΗΑΘ Δ'ΕΔΑΘ ΡΡΥΘΗΤΑΪΛΤΕ ΗΘ ΘΘ ΘΡΘΪΘΗΘΥΡΕΑΘΤ.

5. SCRΪΘΘ ΣΪΘΣ ΗΑ ΞΕΑΡΣΑΪ ΣΘΟ Α ΛΘΑΗΑΣ, ΑΣΥΣ ΡΥΗΗ ΛΙΤΡΘΘΥΡΕΑΘΤΑ ΪΗ ΎΣΑΪΘ ΑΞΑΤ, ΑΡ ΘΪΛΕΘΞ ΑΤΑ 10 ΟΡ. ΡΑΘΪ 8 ΟΡ. ΑΡ Α ΛΑΞΑΘ.

ΘΑΘΥΗΑΘ

ΘΡΘΗ ΑΡ ΑΗ ΗΒΑΪΣ ΣΕ ΘΥΘ ΗΘ ΘΡΟΪΣΕ, Δ'ΡΥΑΘΑΪΞ ΗΘ ΞΡΑ ΊΣ Δ'ΡΑΞ ΗΘ ΘΛΟΪΘΕ, ΞΑΗ ΘΑΡΑ ΞΑΗ ΘΟΜΠΑΗΑΘ ΡΑ ΔΪΘΗΗ ΗΘ ΪΪΣΕ, ΑΘ ΑΗ ΛΕΑΗ ΣΘΟ ΪΗ ΛΑΥ ΑΣΥΣ ΗΘ ΑΞ ΘΑΘΥΗΑΘ.

ΑΞ ΞΑΘΑΪΛ ΑΗ ΤΣΛΕΪΘΕ ΘΘΗ ΤΡΑΪΘΝΗΑ, ΔΘ ΛΑΘΑΥΡ ΑΗ ΘΑΗΛΑΪΘ ΛΥΘΗ ΞΘ ΒΡΘΗΑΘ, ΔΘ ΛΑΘΑΥΡ ΑΗ ΗΑΘΘΘ ΒΪΗΗ ΊΣ ΑΗ ΘΡΟΤΑΘ ΞΪΘΡΑΘ, ΑΞ ΡΑΪΣΗΘΕΪΣ ΘΘΗ ΞΥΡ ΕΑΞ ΗΘ ΣΘΡΑΘ.

P. ΗΑΘ ΡΪΑΡΑΪΣ.

ΡΟΙΗΗ ΙΙ.—(100 ΗΑΡΘ.)

ΞΑΗ ΑΘ ΤΡΪ ΘΘΪΣΤ Α ΘΘΑΗΑΗ.

(ΑΗ ΛΥΑΘ ΘΘΑΗΗΑ ΑΡ ΞΑΘ ΘΘΪΣΤ.)

\* 1. ΤΑΪΣΡΕΑΗΤΑΡ ΑΞΑΪΘΘΕΛΘ ΑΣΥΣ ΣΪΘΣΘΕΛΘ ΘΘ ΘΡΟΪΣ ΣΑ ΛΕΑΡΑΪΘ. ΤΑ ΒΟΗΗ ΗΑ ΘΡΟΪΣΕ ΘΕΑΡΗΘΞΑΘ. ΑΗ ΑΞΑΪΘΘΕΛΘ ΑΣΥΣ ΑΗ ΒΟΗΗΘΕΛΘ Α ΘΑΡΡΑΪΗΞΤ ΘΘ ΡΕΪΡ ΗΑ ΘΥΟΪΣΪ ΑΤΑ ΤΥΞΑ.

\* 2. ΗΑΘΑΣΑΗΑΪΛ Α ΘΘΑΗΑΗ ΘΘΗ ΡΑΤΡΥΗ Α ΘΑΪΣΡΕΑΗΤΑΡ ΘΘ ΡΕΪΡ ΗΑ ΘΥΟΪΣΪ ΑΤΑ ΒΡΕΑΘΤΑ ΑΥΡ. ΗΪ ΗΘΡ ΗΑ ΛΪΗΤΕ ΤΟΞΑΛΑ Α ΘΑΪΣΡΕΑΗΤΑ.

\* 3. ΡΑΤΡΥΗ Α ΘΑΡΡΑΪΗΞΤ ΘΘΗ ΑΗ Τ-ΪΗΘΡΥΘ Α ΘΑΪΣΡΕΑΗΤΑΡ ΞΑΗ ΛΕΑΡΑΪΘ Α ΛΪΘΗΑΘ, ΘΘ ΡΕΪΡ ΗΑ ΘΥΟΪΣΪ ΑΤΑ ΒΡΕΑΘΤΑ ΑΥΡ.

\* 4. ΤΑΪΣΡΕΑΗΤΑΡ ΑΞΑΪΘΘΕΛΘ (Α), ΒΟΗΗΘΕΛΘ (Β), ΑΣΥΣ ΣΪΘΣΘΕΛΘ (Γ) ΘΘ ΘΡΑΘ ΞΑΗ ΛΕΑΡΑΪΘ. ΘΘΑΗ ΤΑΡΡΑΪΗΞΘΑΪΛ ΡΥΘΤΥΡΤΑ ΞΑΘΡΛΪΗΘΟΤΑ ΘΘΗ ΘΡΑΘ, 4 ΟΡΛΑΘ ΑΡ ΑΥΡΘΕ, ΤΥΑΥΡΪΗ.

5. ΞΡΕΑΣ Α ΘΘΑΗΑΗ ΛΘ ΗΑΞΑΪΘ ΡΑΪΗΘΕΪΛ ΑΡ Α ΘΨΥΪΛ ΘΡΥΘ ΘΥΪΞΪΛΕΑΪΗ ΡΑΛΤΑ, 4 ΟΡΛΑΘ ΪΗΑ ΞΪΘΣ. ΘΑΪΞΡΕΑΡ ΑΗ ΞΡΕΑΣ Α ΘΥΗΥ ΑΡ ΟΡΗΑΪΘ ΘΘΪΜΣΕΑΤΥΪΛ, ΑΣΥΣ Ε ΘΕΪΘ ΟΥΡΥΗΑΘ ΘΘ ΘΘΥΡΘ ΕΪΞΪΗ ΑΪΥΡΘΕ.

(ΡΘΔΘ ΛΕΑΡΑΪΘΪ 3 ΑΣΥΣ 4 ΘΑΛΛ.)

