

AN ROINN OIDEACHAIS  
(Department of Education).

BRAINSE AN MHEÁN-OIDEACHAIS  
(Secondary Education Branch).

LEAVING CERTIFICATE EXAMINATION, 1933.

PASS.

MECHANICAL DRAWING AND DESIGN.  
BOYS AND GIRLS.

WEDNESDAY, 21st JUNE.—AFTERNOON, 4 TO 6 P.M.

BOYS ONLY.

NOTE.—The use of mathematical instruments, protractors, scales, T- and set squares, and drawing-boards is allowed.

All construction lines must be clearly shown.

The number of the question must be distinctly marked by the side of each answer. Both sides of the paper may be used.

Questions marked (\*) have accompanying diagrams.

The number of marks assigned to each question is stated in brackets after the question.

Q. 1. Draw a semi-circle of 4 inch diameter, and within it, space in suitable proportion the word “**DRÁMA**” in Gaelic letters.

Or,

The word “**DRAMA**” in Roman letters. [8]

\*Q. 2. Draw to a scale of 1 inch to 1 foot, the iron railing shown in diagram. [10]

\*Q. 3. Draw the given diagram of a chair-back according to the figured dimensions. [10]

\*Q. 4. The elevation of a protractor is given. Draw a new elevation when the plane of the protractor is vertical and inclined to the vertical plane at an angle of 40°. [11]

\*Q. 5. The front and side elevations of a roof and chimney are shown in diagram. Draw the plan and an elevation of the roof and chimney when the long edges of the roof make angles of 30° with the vertical plane.

Scale 1 inch to 16 feet. [14]

Q. 6. Draw a design to occupy a diamond or lozenge-shaped panel, the vertical diagonal being 3 inches and the horizontal diagonal 6 inches. Your design may be composed of Celtic, Floral, or Geometric ornament, and should be suitable for Inlay, Stencilling, Painted Ornament or Repoussé Metal.

Two colours may be used, or your design may be finished in black and white. [22]

## GIRLS ONLY.

**NOTE.**—The use of mathematical instruments, protractors, scales, T- and set squares, and drawing-boards is allowed.

All construction lines must be clearly shown.

The number of the question must be distinctly marked by the side of each answer. Both sides of the paper may be used.

Questions marked (\*) have accompanying diagrams.

The number of marks assigned to each question is stated in brackets after the question.

Q. 1. Draw a semi-circle of  $\frac{1}{4}$  inch diameter, and within it, space in suitable proportion the word "**DRÁMA**" in Gaelic letters.

*Or,*

The word "**DRAMA**" in Roman letters.

[8]

\*Q. 2. Copy the given embroidered pattern to the dimensions shown.

[12]

\*Q. 3. Set out what you consider the necessary construction lines for the given Diaper pattern, using the figured dimensions. Complete at least *one-half* of the diagram.

[9]

\*Q. 4. Draw the pattern to the dimensions given.

[10]

\*Q. 5. The plan and side elevation of a tea-caddy are given. Draw the front elevation. Thickness of material to be neglected. Show how you would project the given ornament on to the sloping face.

The true shape of face with ornament thereon is shown

[14]

Q. 6. Draw a design for a circular table-mat  $4\frac{1}{2}$  inches diameter. Your design may be based on Celtic, Floral or Geometric ornament, and should be suitable for Embroidery, Stencilling or Modelled Leather.

[22]

GIRLS ONLY.

Q 2.

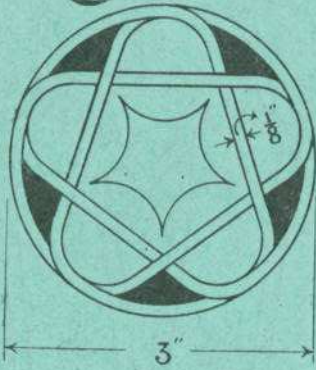

Q 3.

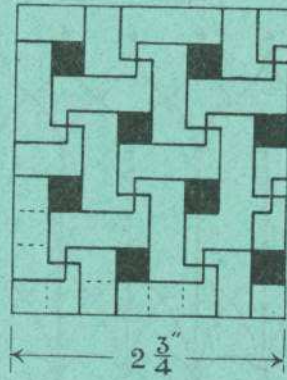

Q 4.

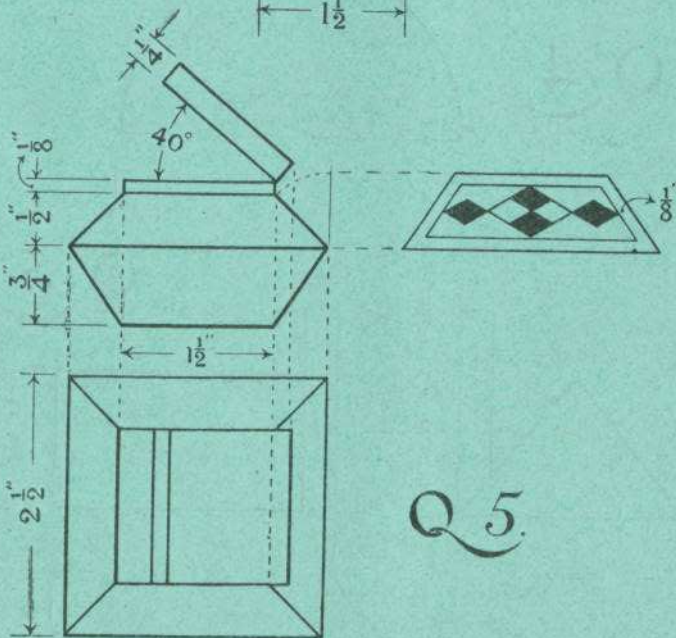
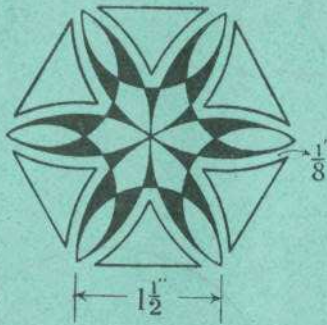

Q 5.

BOYS ONLY.

Q 2.

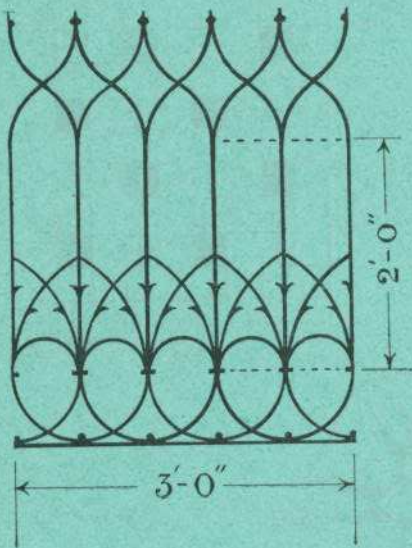

Q 3.

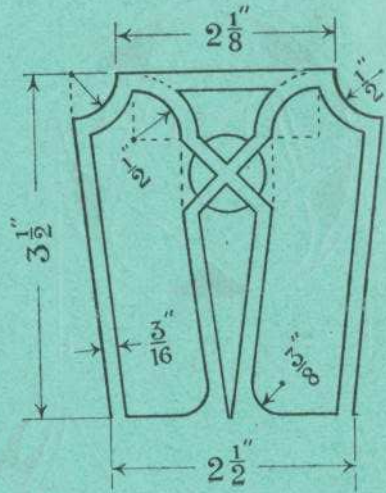

Q 4.

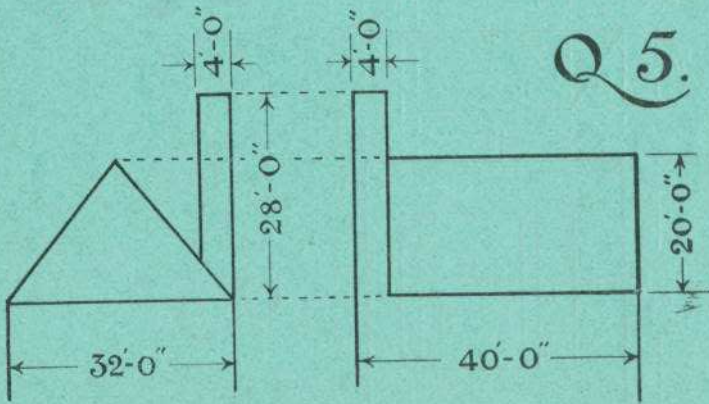
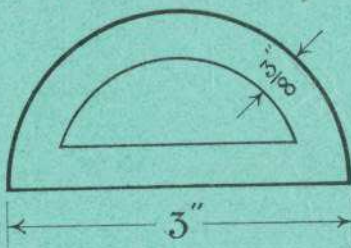

Q 5.