



Coimisiún na Scrúduithe Stáit
State Examinations Commission

Leaving Certificate Examination, 2004

Technical Drawing
Paper II(B) – Higher Level
(Building Applications)

(200 Marks)

Friday 18 June

Afternoon, 2.00 to 5.00

- (a) Answer four questions.*
- (b) All questions carry equal marks.*
- (c) Construction lines must be shown on all solutions.*
- (d) Write the number of the question distinctly on the answer paper.*
- (e) All dimensions on the question paper are given in metres or millimetres.*
- (f) First or third angle projection may be used.*

1. Draw a perspective view of the structure shown in Fig. 1. The picture plane passes through the corner A, the spectator S is 11m from the corner A and the horizon line is 9m above the ground line.

Use auxiliary vanishing points where appropriate.

Scale 1 : 100

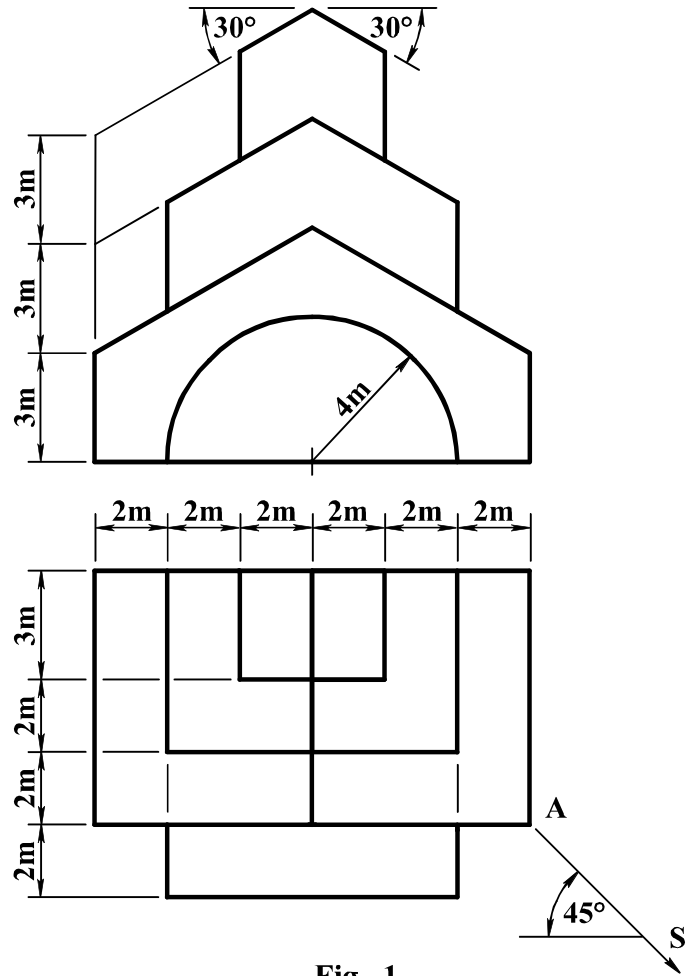

Fig. 1

2. Fig. 2 shows the outline plan and elevation of a roof.

Surface E has a pitch of 35° and surfaces A and C have a pitch of 55° . The dihedral angle between surfaces C and D is 115° .

- Draw the given plan and elevation.
- Develop the surface C.
- Determine the dihedral angle between the surfaces A and B.

Scale 1 : 100

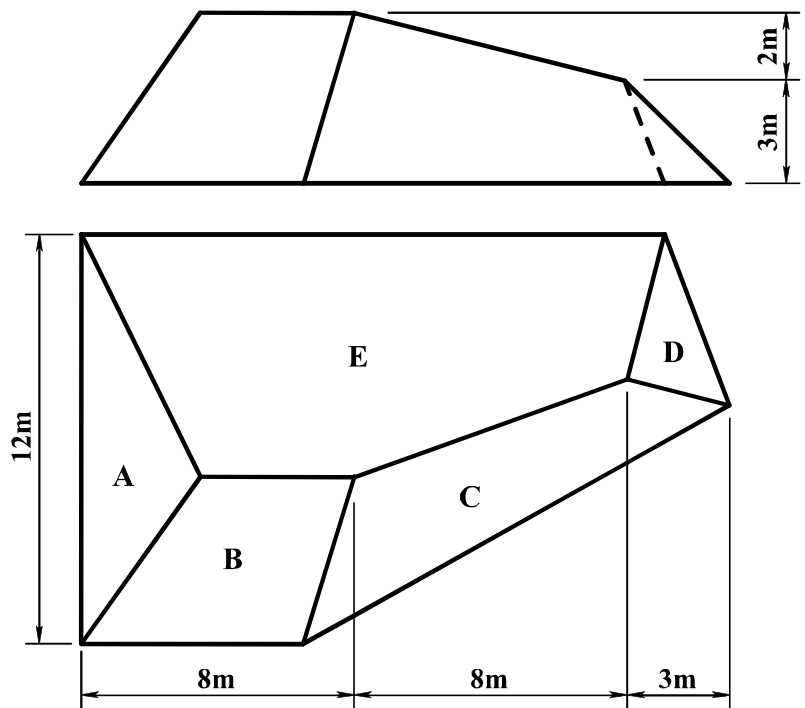

Fig. 2

3. Fig. 3 shows the outline plan and elevation of a structure. The solid is composed of a cone, a portion of a sphere and a cylindrical base.

Draw the given views and determine the shadows and shade in plan and elevation when the direction of the light is as shown.

Scale 1 : 100

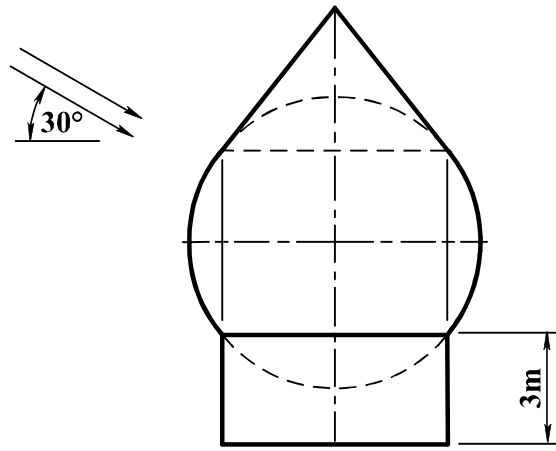
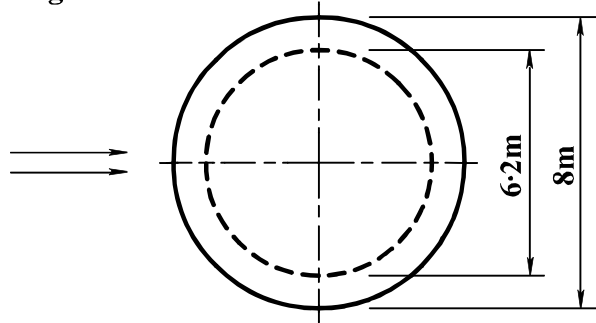

Fig. 3



4. Fig. 4 shows the outline plan and elevation of a building. It is in the form of a hyperboloid of revolution. The outline of an entrance, which projects from the main building, is also shown.

- (a) Draw the plan and elevation of the building.
 (b) Draw a development of the surface A of the entrance.

Scale 1 : 200

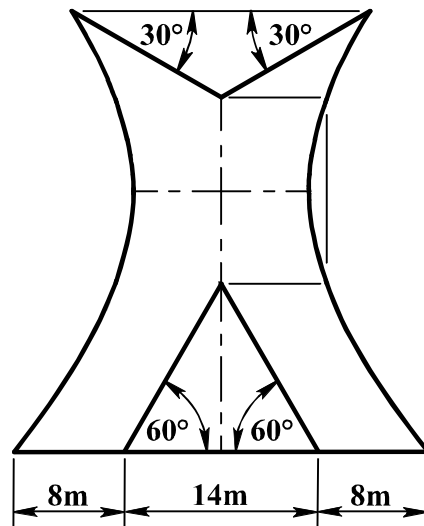
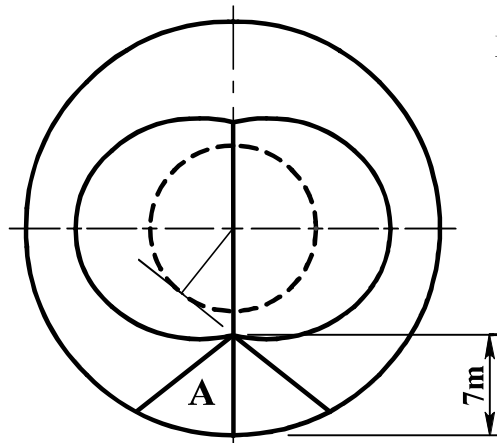

Fig. 4



5. On a contour map A and B are two points whose altitudes are 115m and 105m respectively. On the map B is located 80m north-east of A. A skew bore-hole at A is drilled in a north-westerly direction in plan and has an actual inclination of 50° to the horizontal plane. It reveals the top and bottom surfaces of a stratum at distances of 45m and 95m, respectively, from A.

A skew bore-hole at B is drilled in a south-westerly direction in plan and has an actual inclination of 60° to the horizontal plane. It reveals the top and bottom surfaces of the stratum at distances of 35m and 100m, respectively, from B.

- (a) Determine the dip, strike and thickness of the stratum.
- (b) Another skew bore-hole at B is drilled in a westerly direction in plan and has a true inclination of 45° to the stratum. Determine the altitudes at which the bore-hole reaches the top and bottom surfaces of the stratum.

Scale 1 : 1000

6. Fig. 5 shows the outline plan and elevation of a hyperbolic paraboloid roof. The perimeter of the roof is a circle in plan. The roof was formed by extending the hyperbolic paraboloid surface ABCD.

- (a) Draw the plan and elevation of the roof.
- (b) Determine the true shape of the section S-S through the roof.
- (c) Determine the traces of the plane director for the elements AB and DC, having its horizontal trace passing through B.
- (d) Determine the true angle between the vertical trace and the horizontal trace on the plane director.

Scale 1 : 200

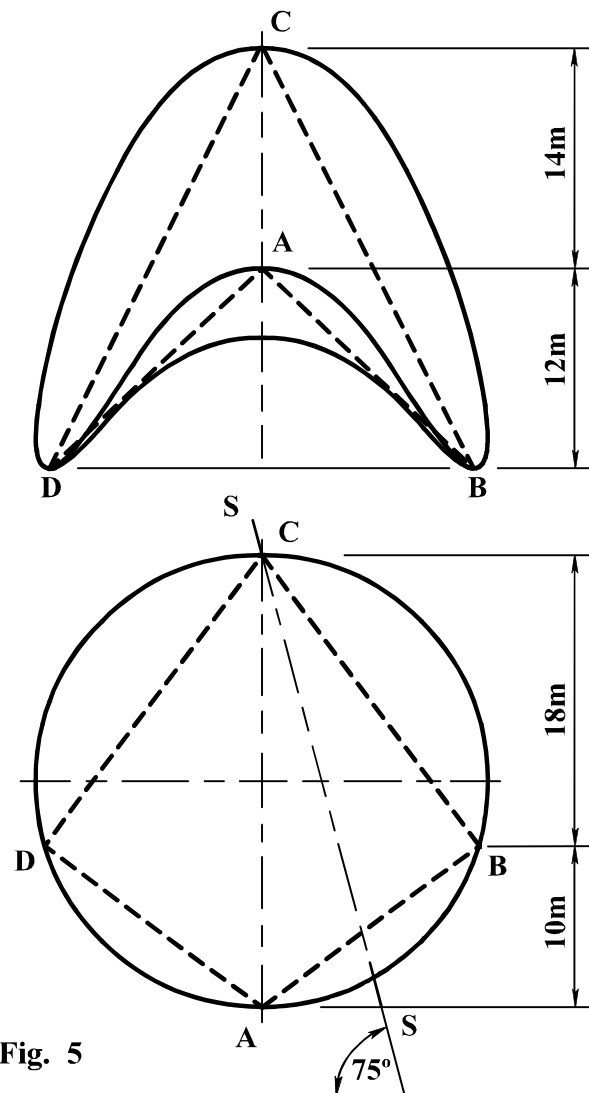

Fig. 5

7. The accompanying drawing shows ground contours at five-metre vertical intervals. AD is the line of a proposed roadway. The roadway is widened between B and C to form a parking area.

The roadway has the following specification:-

- (i) formation widths are as shown;
- (ii) formation level at B is 55m;
- (iii) A to B is level;
- (iv) gradient B to D is 1 in 15 rising;
- (v) side slope for embankments is 1 in 2;
- (vi) side slope for cuttings is 1 in 1.5.

On the drawing supplied, show the earthworks necessary to accommodate the roadway.

(M85L)

Coimisiún na Scrúduithe Stáit
State Examinations Commission
Scrúdú Ardteistiméireachta, 2004
Leaving Certificate Examination, 2004

Scrúduitheir:
Examination Number:

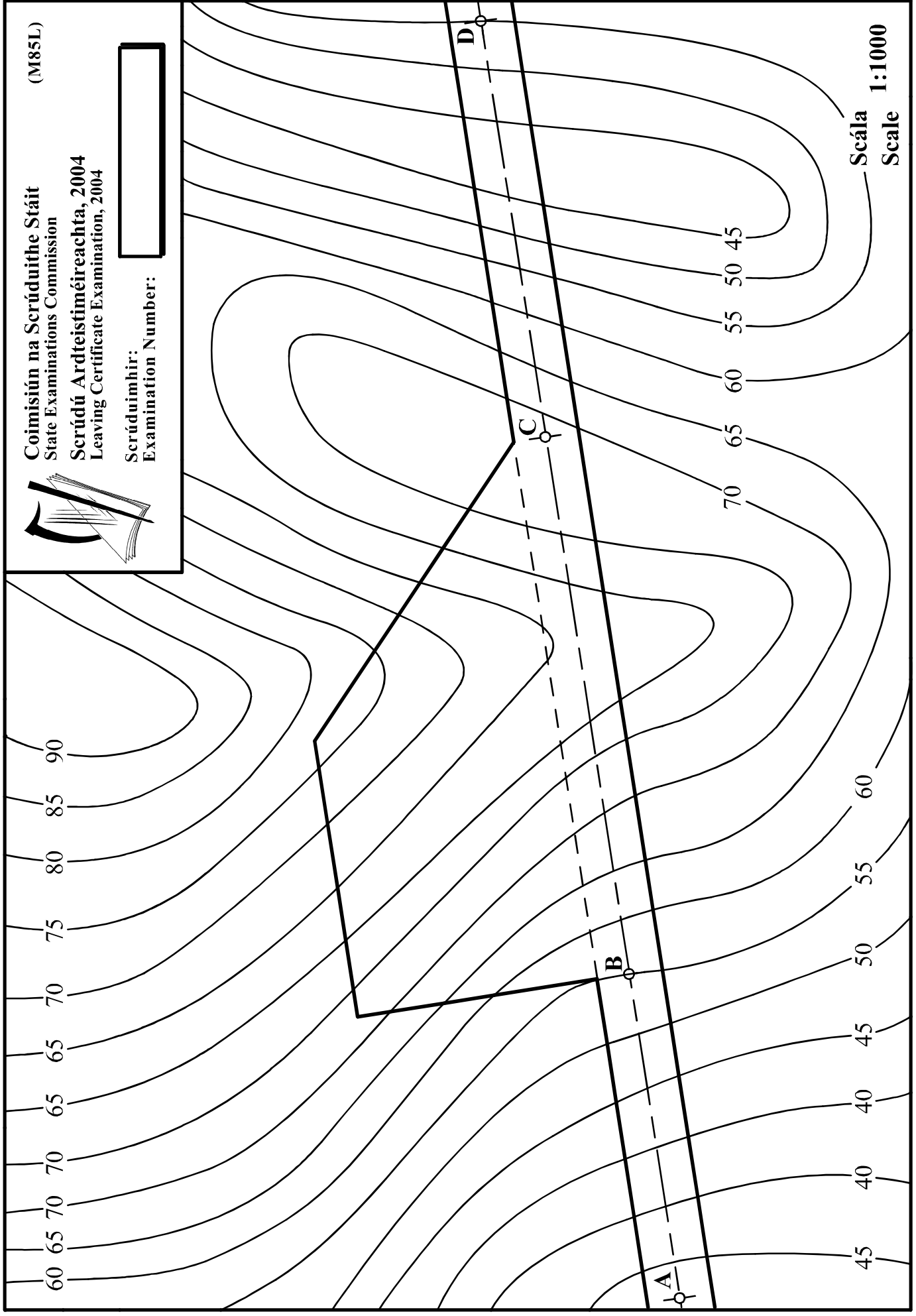

Scála 1:1000
Scale