

**AN ROINN OIDEACHAIS AGUS EOLAÍOCHTA**  
**LEAVING CERTIFICATE EXAMINATION, 1998**

**M.84**

7972

**TECHNICAL DRAWING - HIGHER LEVEL**  
**PAPER II(A) - ENGINEERING APPLICATIONS**

**Tuesday, 23 June, Afternoon 2.00 – 5.00 pm**

**200 Marks**

**INSTRUCTIONS**

- (a) Answer four questions.
- (b) All questions carry equal marks.
- (c) Drawings and sketches should be in pencil unless otherwise stated.
- (d) Where dimensions are omitted they may be estimated.
- (e) Credit will be given for neat orderly presentation of work.
- (f) Candidates should work on one side of the paper only.
- (g) The Examination Number should be written on each drawing sheet used.
- (h) All dimensions are in millimetres.

- 
1. Details of an Inspection Stand are given in Fig. 1 with the parts list tabulated below.
- (a) Draw a full size sectional elevation A-A showing the parts fully assembled.
  - (b) Insert item reference numbers to identify the parts and add the title INSPECTION STAND.
  - (c) With the aid of a neat freehand sketch suggest a modification to the design which will ensure that the Column (Part 2) is prevented from rotating in the hole in the Base (Part 1).

PART	NAME	REQUIRED
1	BASE	1
2	COLUMN	1
3	BRACKET	1
4	ADJUSTMENT NUT	1

2. A sheetmetal transition piece, used to connect a rectangular chute to a cylindrical pipe, is shown in Fig. 2.

- (a) Draw the given views and produce a one piece development of the transition piece. The development should have the shortest seam possible.
- (b) Sketch freehand the following sheetmetal joints:-  
 (i) Grooved seam joint;  
 (ii) Double grooved seam joint;  
 (iii) Safe edge.

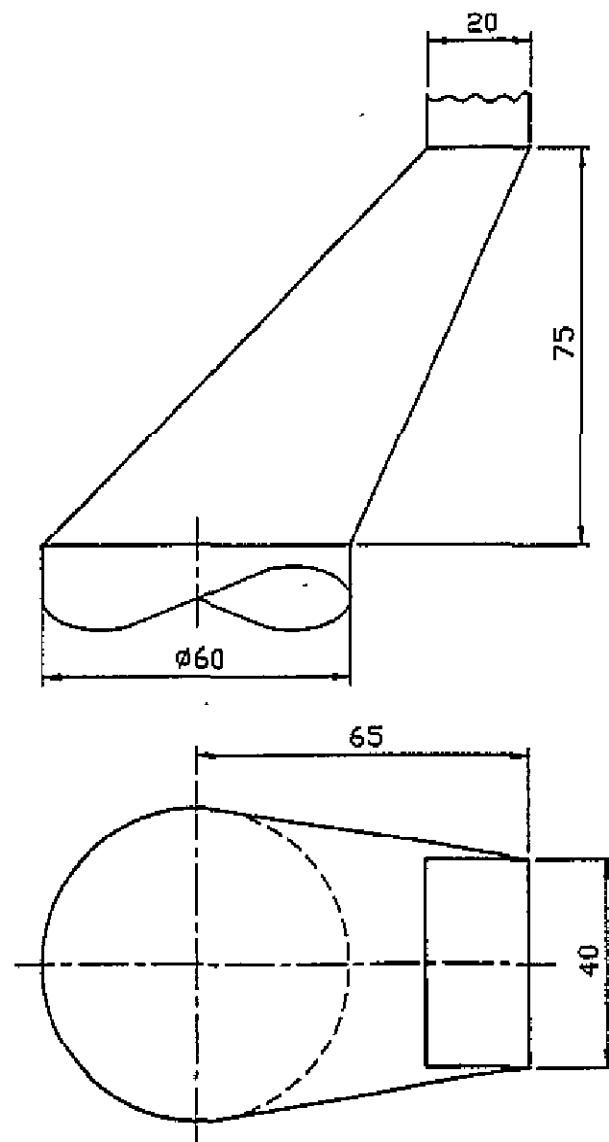

FIG. 2

3. (a) Draw the profile and displacement diagram for a cam rotating in a clockwise direction and imparting the following motion to an in-line knife edge follower:-

- 0° to 120° rise 36mm with Uniform Acceleration and Retardation.
- 120° to 180° dwell.
- 180° to 270° fall 18mm with Simple Harmonic Motion.
- 270° to 360° fall 18mm with Uniform Motion.

The minimum distance between the central axis and the cam edge is 50mm.

(b) In the mechanism shown in Fig. 3 the crank OA rotates at constant speed, in an anti-clockwise direction, about O. The arm BD oscillates about a fixed pivot C and is connected to the crank OA by the link AB. The connecting rod DE links the arm BD with the piston at E.

- (i) Draw a displacement diagram and plot the displacement of E for one revolution of OA.
- (ii) Measure and dimension on the drawing the length of stroke of the piston E.

4. (a) A sectional view of a bevel gear arrangement is shown in Fig. 4. The following twelve parts are identified with item reference numbers 1 to 12:-

Ball bearing, Tapered roller bearing, Internal circlip, External circlip, Hex head set screw, socket head set screw, Crown wheel, Pinion, Woodruff key, Feather key, Dowel pin, Oil seal.

Draw a parts list which tabulates the item number and name for each of these parts.

- (b) Make a neat sketch, either freehand or with the aid of instruments, of the elevation and side elevation of the main shaft, part 13, shown in Fig. 4. This shaft has six equi-spaced holes for set screws and two equi-spaced holes for dowel pins. The sketch may be drawn to any suitable scale and should provide a complete shape description of the part.

- (c) Make a neat sketch, either freehand or with the aid of instruments, showing the profile of three involute gear teeth and indicate on the sketch the following gear tooth terms and features:-

Tip circle, Pitch circle, Base circle, Root circle, Tip, Root, Flank, Root fillet, Tooth thickness, Circular pitch, Addendum, Dedendum.

5. The plan and elevation of a machine casting are shown in Fig. 5.

- (a) Draw the sectional elevation A-A of the casting.
- (b) Draw an isometric view of half of the casting, cut on the section plane A-A. Hatch the cut faces.

6.

Answer **SECTION A** or **SECTION B** but not both.

**SECTION A**

- (a) Produce a neat freehand sketch of a sectional view through a piston, typical of the type of piston used in any common internal combustion engine. Label and indicate on the sketch the Crown, Skirt, Piston ring grooves and Gudgeon pin bosses.
- (b) Produce a neat freehand sketch showing the mechanism used to operate the valves of an internal combustion engine. The sketch should include the Camshaft, Push rod, Valve, Valve spring and Rocker arm. Label these parts on the sketch.
- (c) Produce a neat freehand sketch showing the following structural steel sections:-  
(i) Universal Beam.  
(ii) Angle.  
(iii) Tee section.  
(iv) Channel.  
Indicate on your sketch a Flange, Web, Toe and Heel feature, as applied to any of these sections.

**SECTION B**

- (a) Draw the profile that would be created on CAD as follows:-  
• Lines are drawn from point 1 (X0, Y0), to point 2(X40, Y0), to point 3(X60, Y20), to point 4(X60,Y80), to point 5(X40, Y100), to point 6(X0, Y100) and back to point 1.  
(Note: All points are created using absolute co-ordinate input).  
• Two circles of radius 10mm are drawn with one circle centre at co-ordinate (X25, Y50) and the other centre at co-ordinate (X60, Y50).  
• The portion of any circle which is outside the profile created by the lines is trimmed away and the portion of any line passing through a circle is trimmed.
- (b) With the aid of sketches and a brief note explain the use of the following CAD commands:-  
(i) MIRROR                      (ii) TRIM                      (iii) ROTATE
- (c) With the aid of sketches explain the use of the following solid modelling operations:-  
(i) UNION                      (ii) SUBTRACTION                      (iii) INTERSECTION
- (d) With the aid of a simple sketch show the parameters that you would have to indicate, or set, when hatching on a CAD system.
- (e) List the commands you would use, in the sequence that you would use them, to convert the drawing shown in Fig. 6(B)1 into the drawing shown in Fig. 6(B)2.

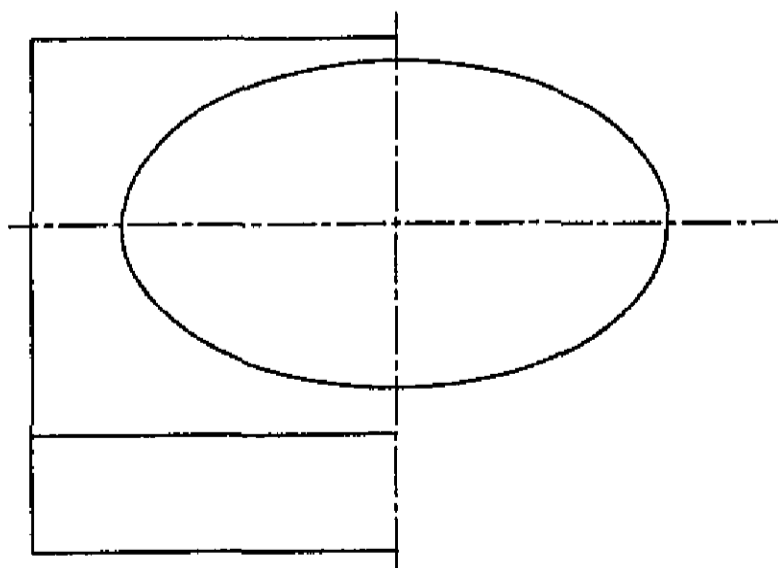

FIG. 6(B)1

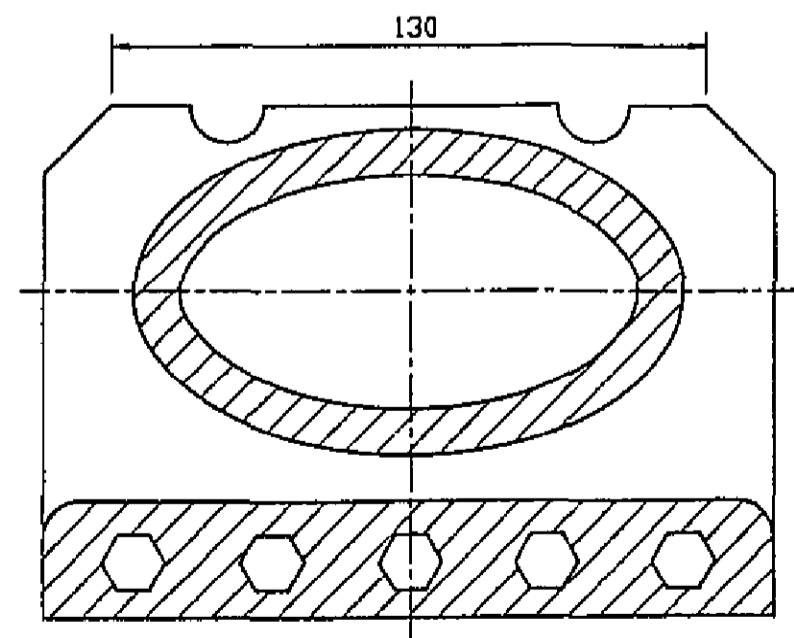

FIG. 6(B)2

**1998**

**LÍNÍOCHT THEICNIÚIL - ARDLEIBHÉAL**

**PÁIPÉAR II(A)**

**FEIDHMIÚCHÁIN INNEALTÓIREACHTA**

**AN ROINN OIDEACHAIS AGUS EOLAÍOCHTA**

**LEAVING CERTIFICATE EXAMINATION**

**1998**

**TECHNICAL DRAWING - HIGHER LEVEL**

**PAPER II(A)**

**ENGINEERING APPLICATIONS**

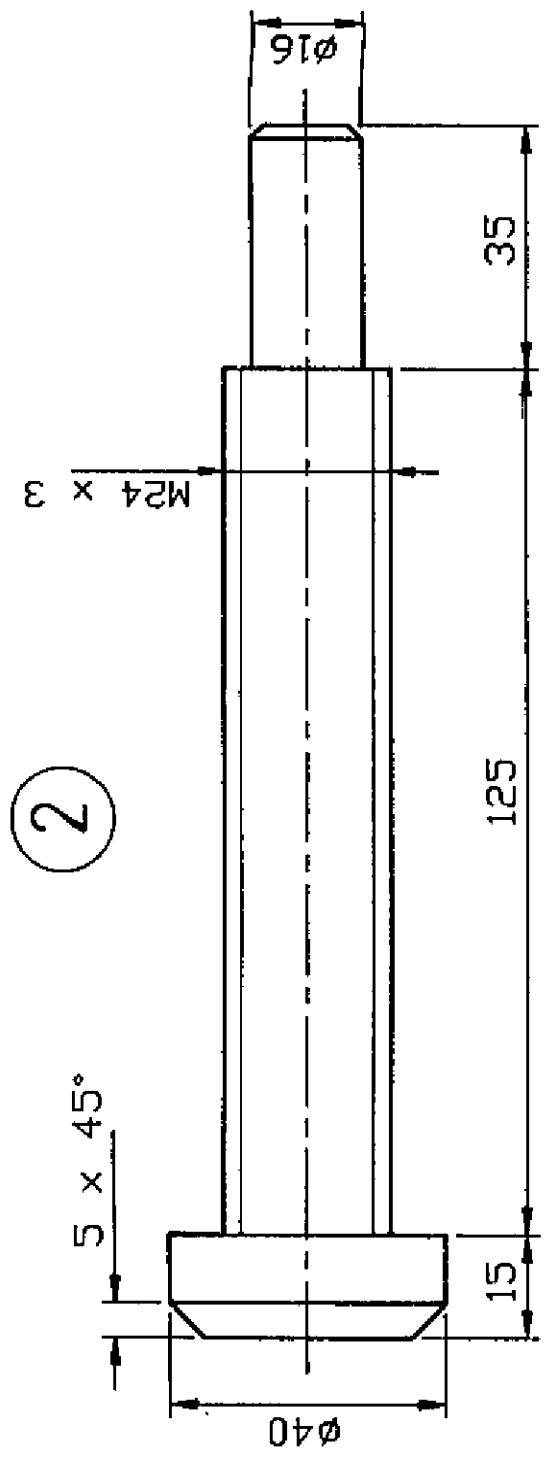

3

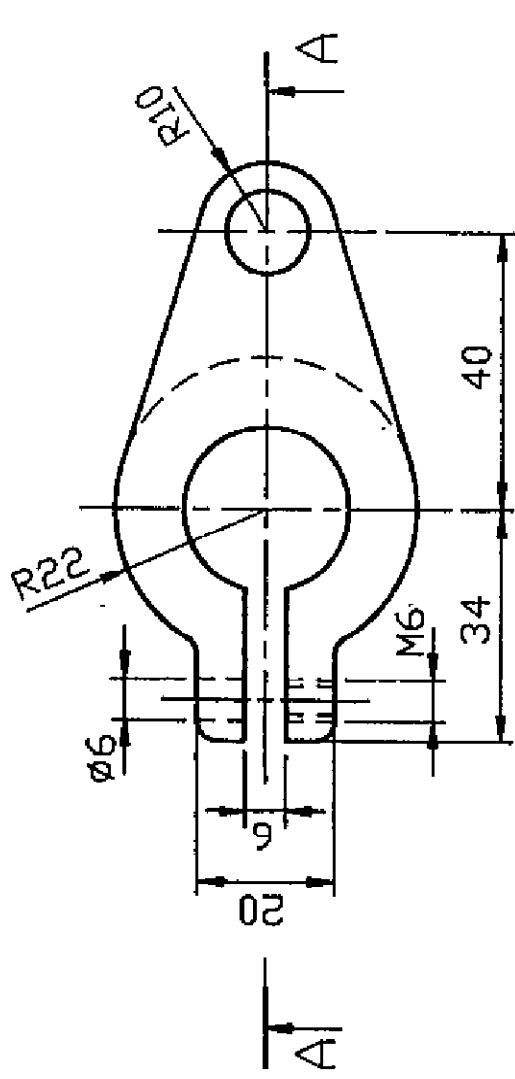
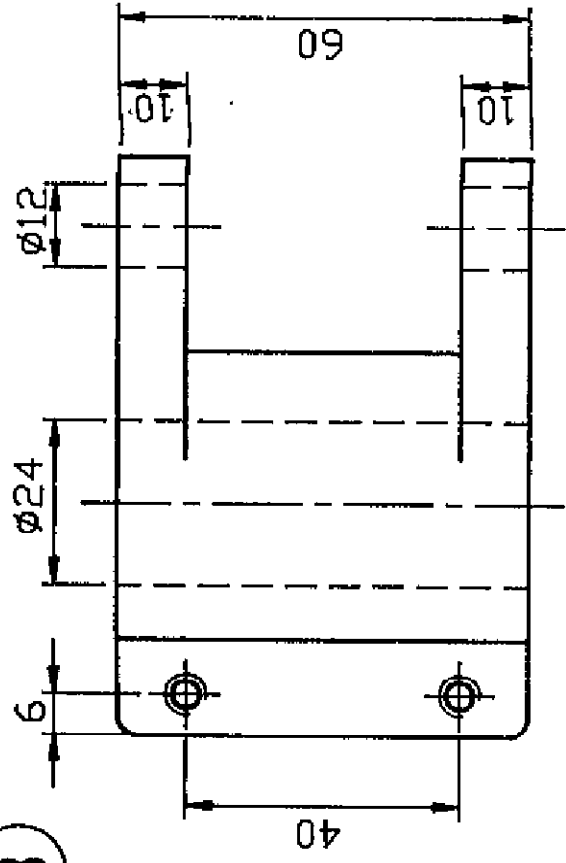

FILLÉID  
FILLETS R3

4

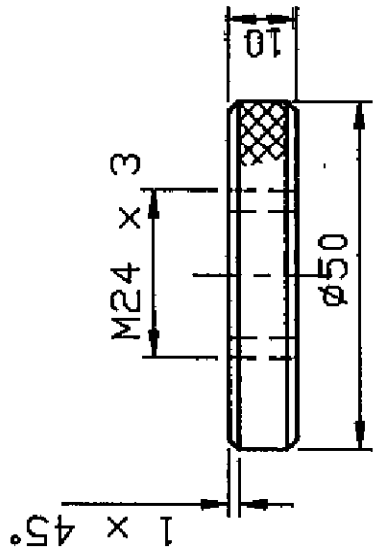

1

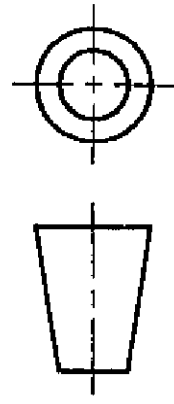
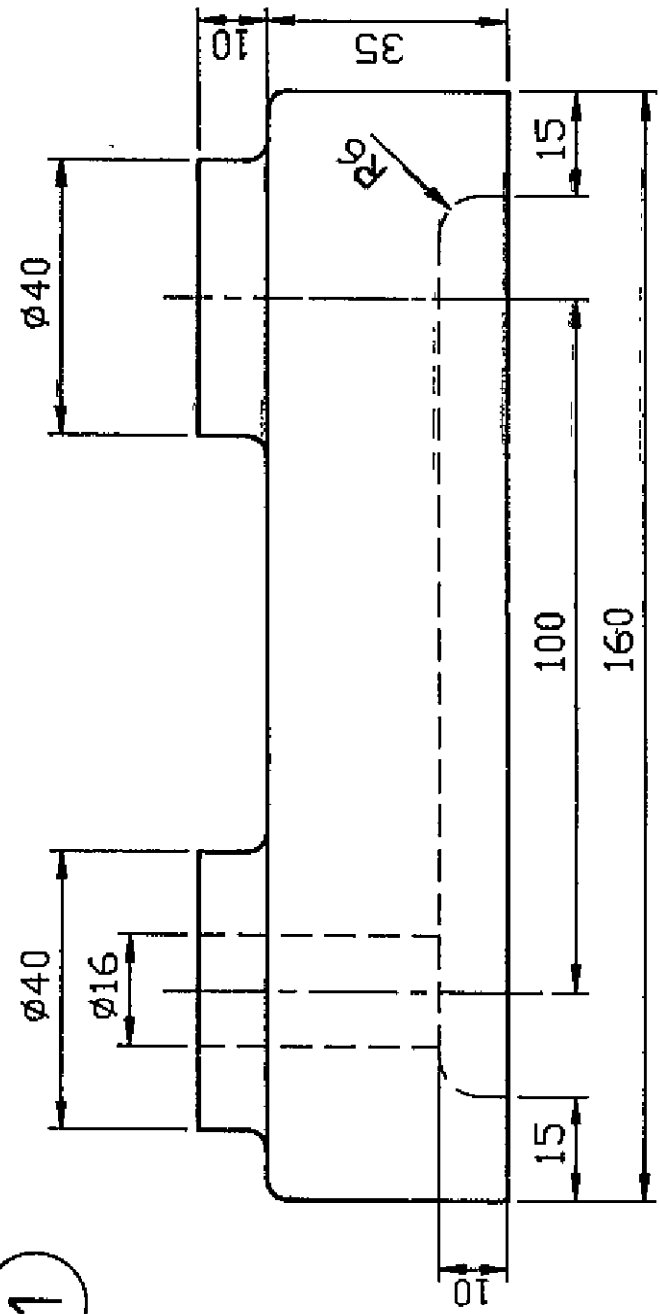

FÍOR 1

FIG. 1

- OA = 30
- AB = 90
- BC = 70
- CD = 50
- DE = 100

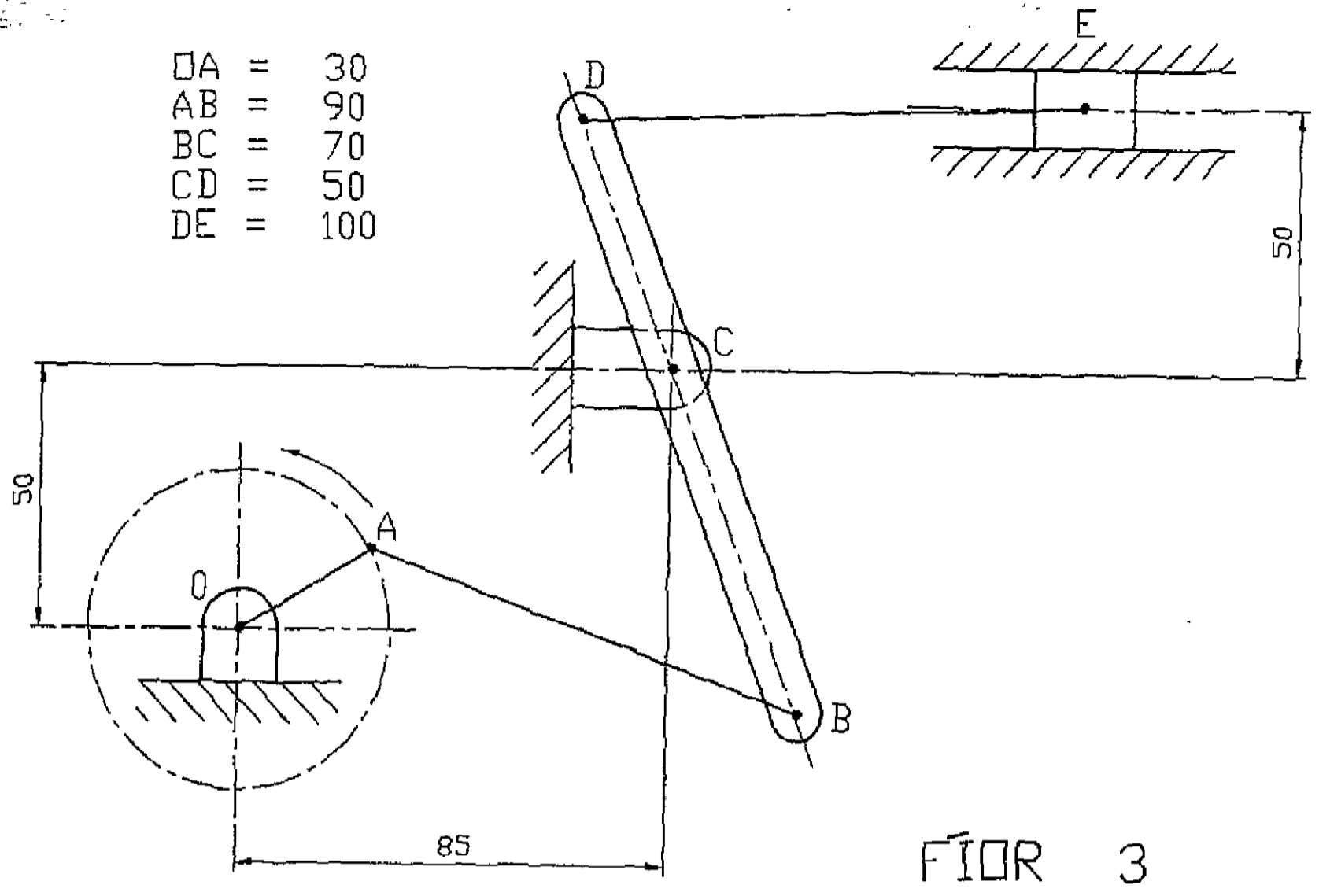

FIG. 3

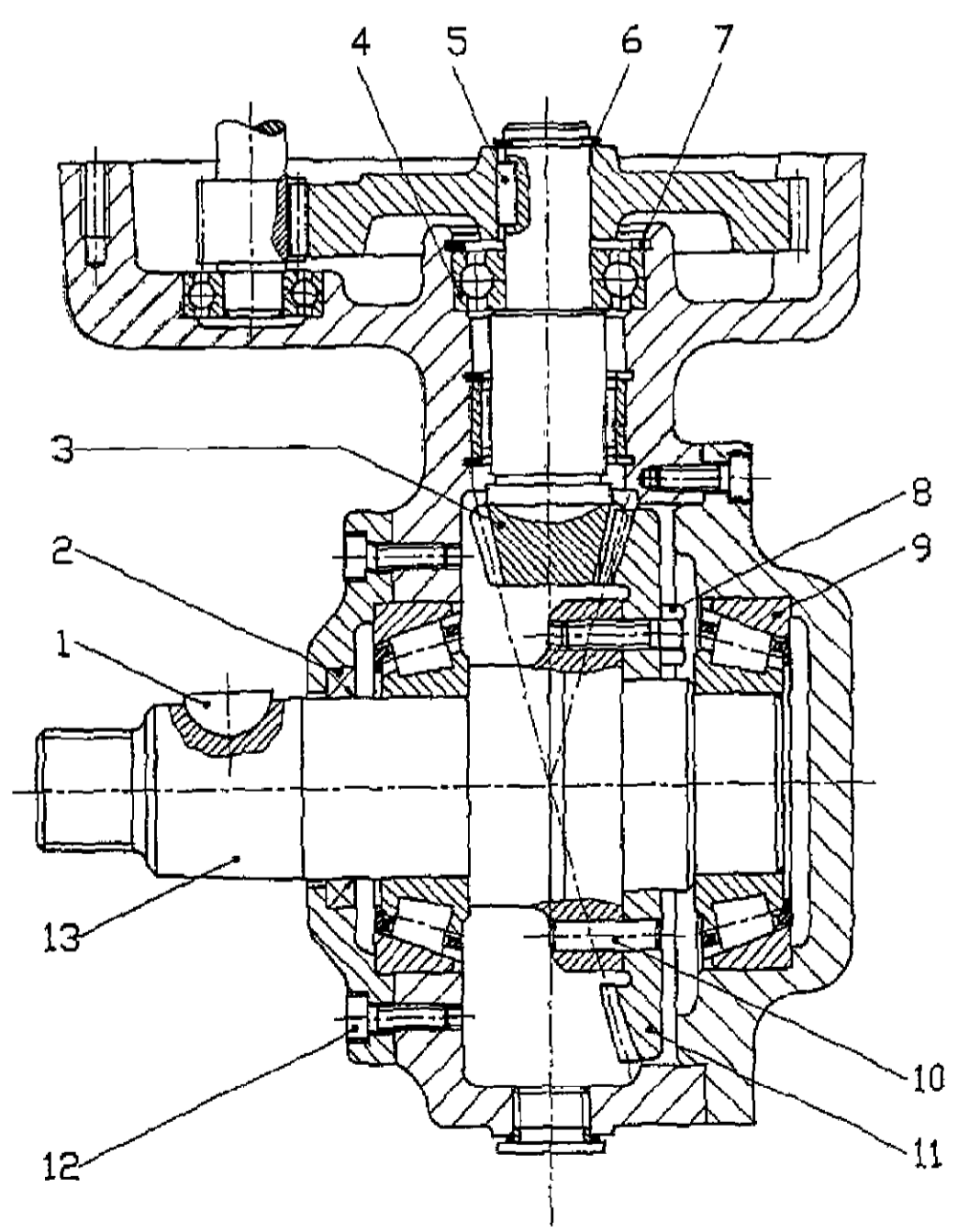
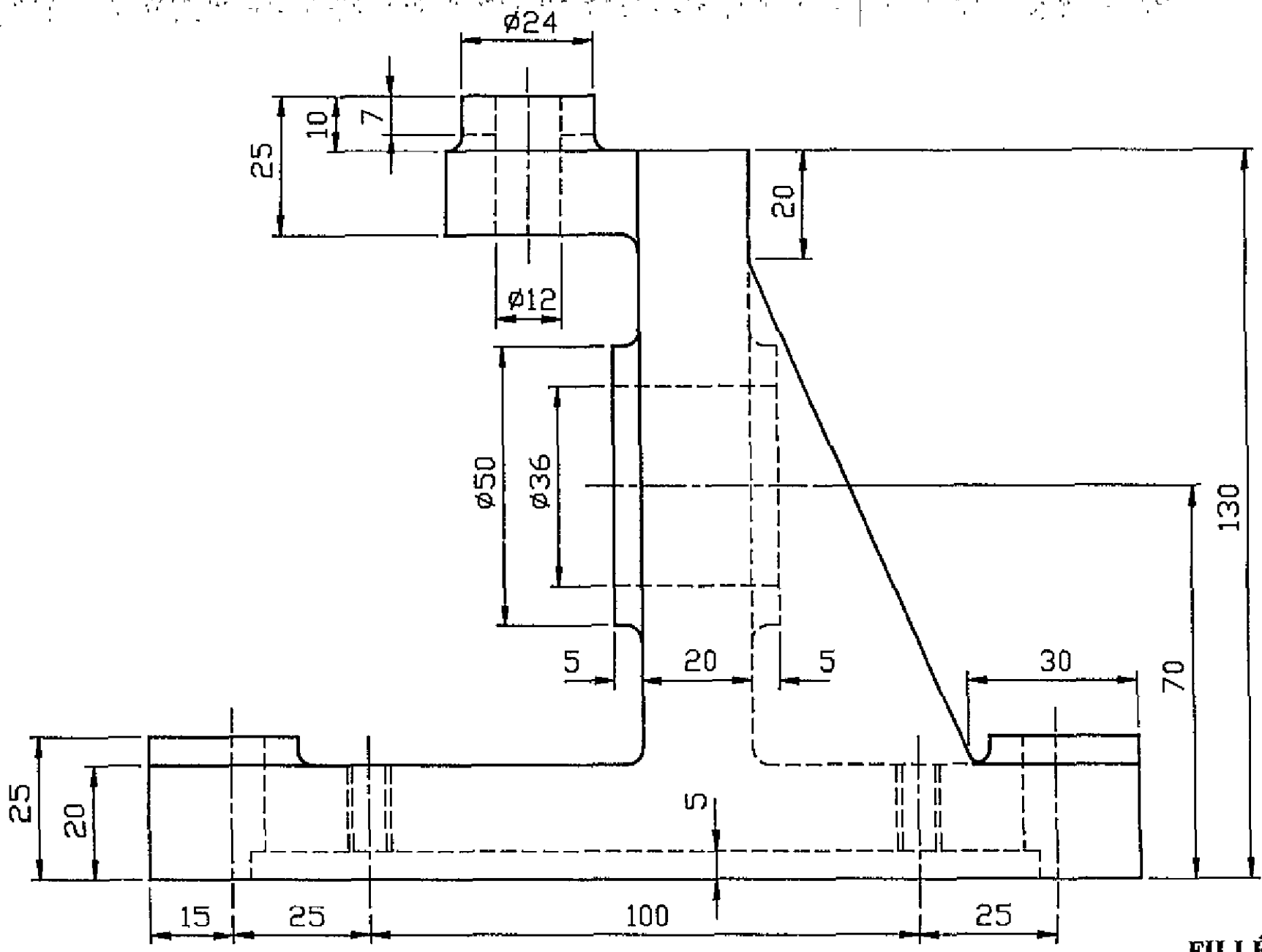
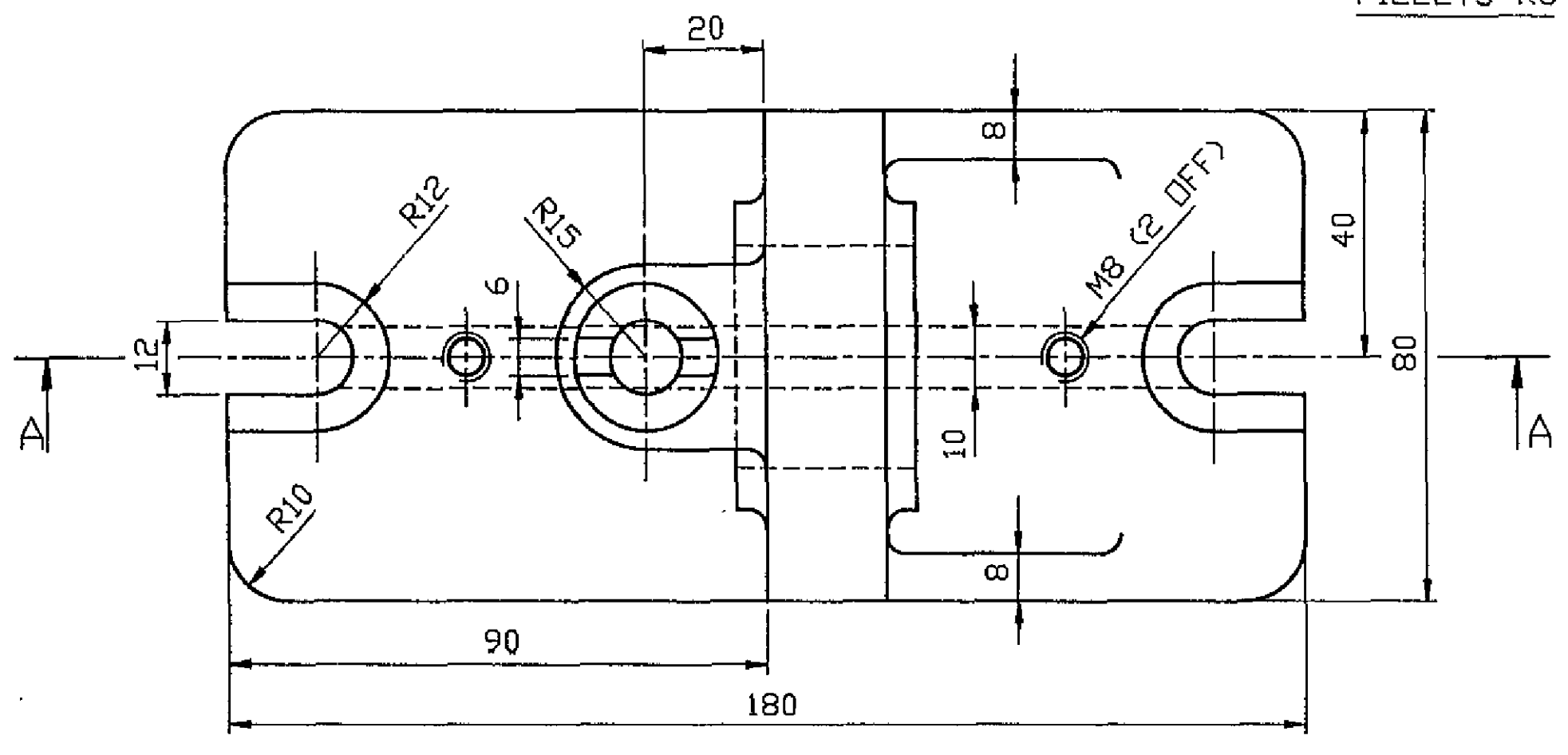

FIG. 4



FILLÉID  
 FILLETS R3



FÍOR 5 FIG. 5

