

AN ROINN OIDEACHAIS
(Department of Education).

BRAINSE AN MHEÁN-OIDEACHAIS.
(Secondary Education Branch).

LEAVING CERTIFICATE EXAMINATION, 1930.

HONOURS.

MECHANICAL DRAWING AND DESIGN.
BOYS AND GIRLS.

WEDNESDAY, 18th JUNE.—AFTERNOON, 4 TO 6 P.M.

BOYS ONLY.

NOTE.—The use of mathematical instruments, protractors, scales, T- and set squares, and drawing-boards is allowed.

All construction lines must be clearly shown.

The number of the question must be distinctly marked by the side of each answer. Both sides of the paper may be used.

Questions marked (*) have accompanying diagrams.

The number of marks assigned to each question is stated in brackets after the question.

*Q. 1. Draw, to a scale of $\frac{3}{4}$ of an inch to 1 foot, the diagram of the Template, to the given dimensions. The methods of finding tangents and points of contact must be clearly shown. [10]

*Q. 2. The elevation is given of an equilateral triangular right prism standing on one short edge on top of a circular slab.

Draw the plan with the axis of the prism and a diameter of the slab in a vertical plane parallel to X.Y. Show plan of section made by inclined plane SN. [11]

*Q. 3. The front and end elevations of a roll-top desk with knee opening are given.

Draw the plan and elevation when the long edges of the desk make angles of 30° with the vertical plane. Scale, $\frac{1}{4}$ -inch to 1 foot. [13]

*Q. 4. Construct a diagonal scale $\frac{1}{4}$ full size to measure up to 8 feet and showing inches. Draw to this scale a figure similar to the given diagram and measure the length of the side on the angle of 40° . [11]

*Q. 5. Draw the pattern to the given dimension. [8]

Q. 6. Make a design for the top of a playing-card box 4 inches by 3 inches. The design is to include the word "CARDS" or "CÁRTAÍ" in bold lettering, and must be suitable for reproduction in Metal, Inlay, or Woodcarving. State the material and process to which the design is adapted. [22]

Or:—

Make a design for the front of a sports programme to occupy a space of 6 inches by $2\frac{1}{2}$ inches, to be printed in black and white on a coloured ground or in two colours on a white ground. The design is to include the word "SPORTS" or "SPÓRSA" in bold letters.

State the process by which your design could be reproduced.

[22]

GIRLS ONLY.

NOTE.—The use of mathematical instruments, protractors, scales, T- and set squares, and drawing-boards is allowed.

All construction lines must be clearly shown.

The number of the question must be distinctly marked by the side of each answer. Both sides of the paper may be used.

Questions marked (*) have accompanying diagrams.

The number of marks assigned to each question is stated in brackets after the question.

*Q. 1. The plan and elevation of a trinket-box are given. Draw the plan and elevation when the long edges of the box make angles of 30° with the vertical plane. Draw the true shape of face A. [12]

*Q. 2. An all-over pattern is given. Draw full size to the dimensions shown. It will be sufficient to complete the section on A, B, C, D. [11]

*Q. 3. Copy the given figure to the measurements indicated. [10]

*Q. 4. An ornamental motif, adapted from decoration on the leather satchel of the shrine of *Maonoh* in the National Museum, Dublin, is given. Draw full size to the dimensions shown. [10]

*Q. 5. Draw clearly with instruments the construction you would use in setting out the repeat of a border shown in diagram. The interlacing bands are equal in width throughout. [10]

Q. 6. Make a design for a monogram to occupy a space 6 inches square. The letters A, B, C, in Roman characters or, *A, B, C*, in Gaelic characters, must form an important part of the design.

The design may be based on natural forms ornamentally treated or on Celtic ornament and should be adapted to some special process of reproduction which must be stated. [22]

Or,

Design a border for a tea-cup to be carried out in four colours including the background. The repeat is to be 4 inches long and the width to be in suitable proportion. [22]

GIRLS ONLY.

Q1.

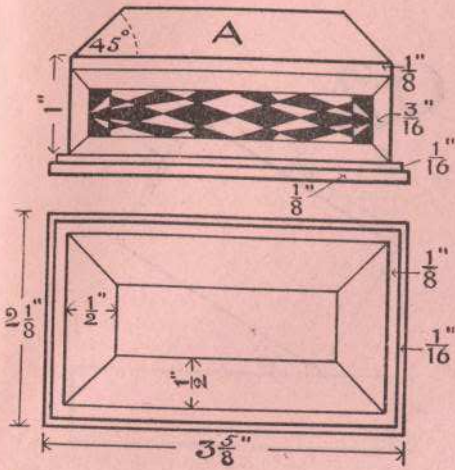

Q2.

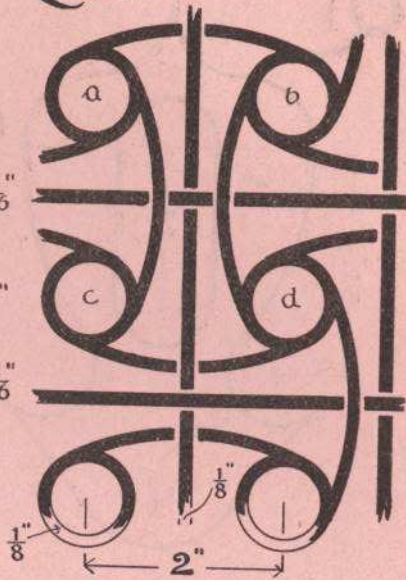

Q4.

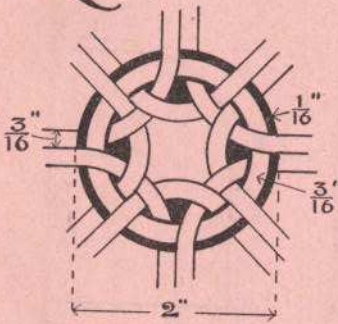

Q3.

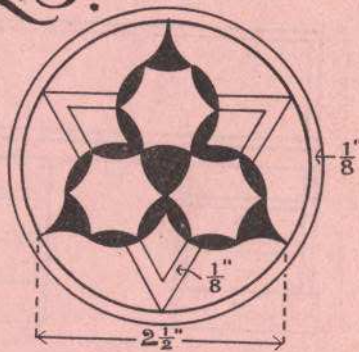

Q5.

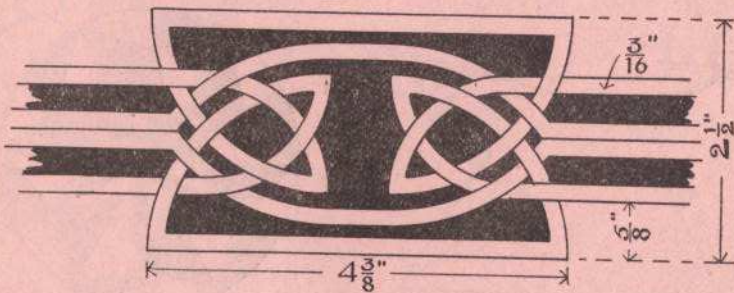

BOYS ONLY.

Q1.

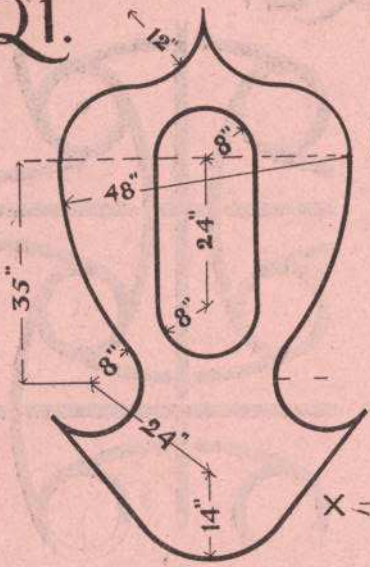

Q2.

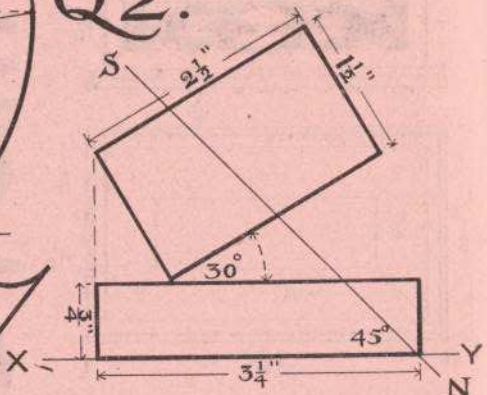

Q3.

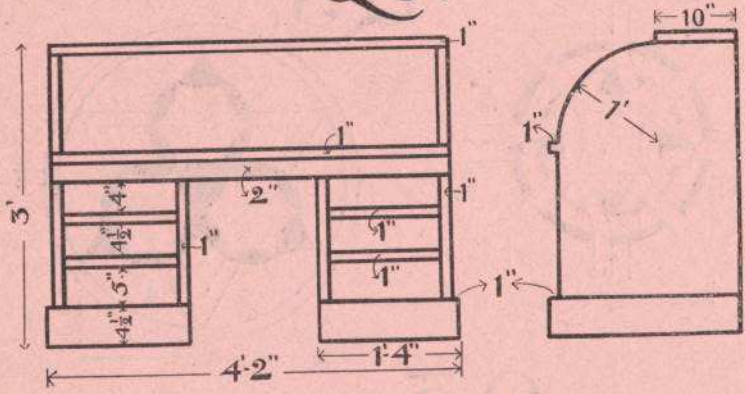

Q4.

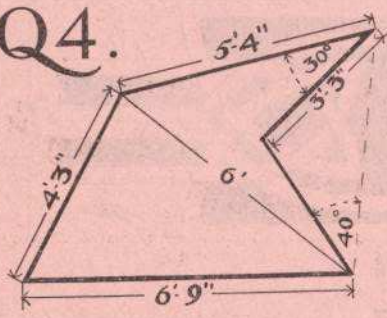

Q5.

