

AN ROINN OIDEACHAIS

(Department of Education).

BRAINSE AN MHEAN-OIDEACHAIS

(Secondary Education Branch).

LEAVING CERTIFICATE EXAMINATION, 1929.

HONOURS

MECHANICAL DRAWING AND DESIGN BOYS AND GIRLS.

WEDNESDAY, 19th JUNE.—AFTERNOON, 4 to 6 P.M.

BOYS ONLY.

NOTE.—The use of mathematical instruments, protractors, scales, T- and set squares, and drawing-boards is allowed.

All construction lines must be clearly shown.

The number of the question must be distinctly marked by the side of each answer. Both sides of the paper may be used.

Questions marked (*) have accompanying diagrams.

The number of marks assigned to each question is stated in brackets after the question.

*Q. 1. Draw, to a scale of 1 inch to 1 foot, the diagram of the Crane Hook to the given dimensions. The methods of finding the tangents and points of contact must be clearly shown.

[12]

*Q. 2. The diagram gives the elevation of a hexagonal right pyramid.

Draw the plan and show the section made by the horizontal plane E.F.

[14]

*Q. 3. The front and end elevations of a stool are given. Draw the plan and elevation when the long edges of the stool make angles of 30° with the vertical plane.

Scale 1 inch to 1 foot.

[14]

*Q. 4. Construct a diagonal scale of 3 inches to 15 feet to show feet and inches. Draw to this scale the given plan of a floor.

[12]

*Q. 5. The drawing of a wheel-barrow is given in plan and elevation. Draw a new elevation on X^1Y^1 .

Scale $\frac{3}{4}$ inch to 1 foot.

[16]

Q. 6. Make a design for an electric door-bell to occupy a square of 5 inches side or a circle of 5 inches diameter. Embody in the design the words "DAY BELL" or "cloḡ an tae" in bold lettering.

The design should be adapted to reproduction in wood, bronze, or repoussé metal.

State the material and process to which the design is adapted.

[32]

Or :—

Design a label for a Jam Jar. The label may be rectangular or elliptical in shape $4\frac{1}{2}$ inches by 3 inches, to be printed in two colours on coloured or white paper. The words "PLUM JAM" or "suḃ pluma" in bold letters to form an essential part of the design.

State the process by which your design could be reproduced.

[32]

GIRLS ONLY.

NOTE.—The use of mathematical instruments, protractors, scales, T- and set squares, and drawing-boards is allowed.

All construction lines must be clearly shown.

The number of the question must be distinctly marked by the side of each answer. Both sides of the paper may be used.

Questions marked (*) have accompanying diagrams.

The number of marks assigned to each question is stated in brackets after the question.

*Q. 1. The plan and elevation are given of a lamp-stand. Draw a new elevation on X^1Y^1 .

[20]

*Q. 2. The diagram shows an inlaid wood mirror frame. Draw the frame to the dimensions given. It will suffice if the upper half of the frame is completed.

[12]

*Q. 3. A linoleum floor-pattern is shown in diagram. Draw four repeats from the given dimensions.

[12]

*Q. 4. Show clearly with instruments, the geometrical constructions you would use in setting out one-quarter of the lace handkerchief shown in diagram.

[14]

*Q. 5. An embroidered pattern is given. Draw the pattern to the dimensions indicated.

[10]

Q. 6. Draw a design for an embroidered or stencilled Cot-Cover 3 feet by 2 feet. The words "**SLEEP GENTLY**" or "**κόσμιε ύπν σαμ**" should be embodied in the design.

Scale $2\frac{1}{2}$ inches to 1 foot.

State by what method and in what material your design could be suitably carried out.

[32]

Or :—

Make a design for a Menu Card 7 inches by $4\frac{1}{2}$ inches. The design may be either in black and white or in two colours. The word "**MENU**" or "**κλάρ βιό**" to form an important feature of the design. A blank space to be left for the various items.

State the process by which your design could be reproduced.

[32]

GIRLS ONLY.

Q1.

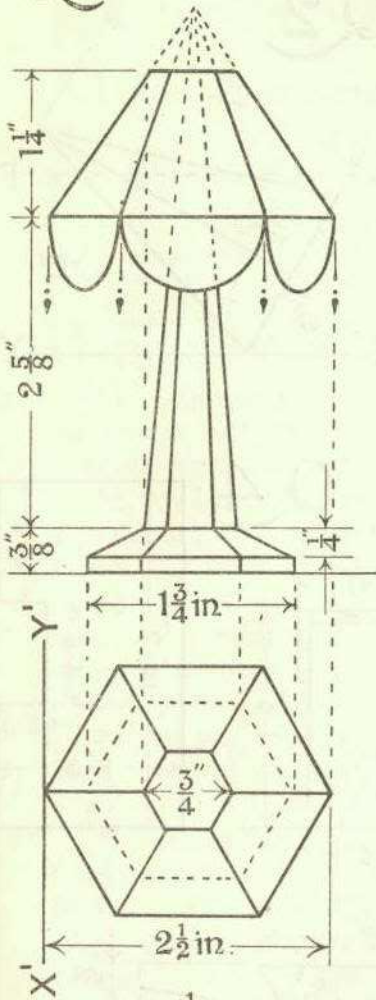

Q2.

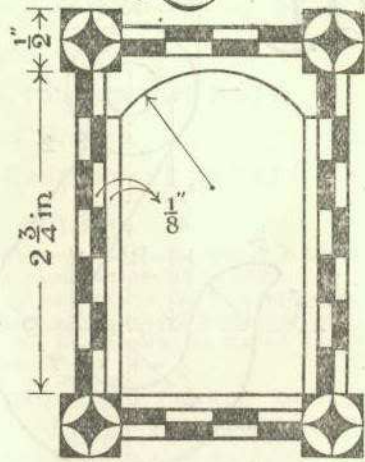

Q3.

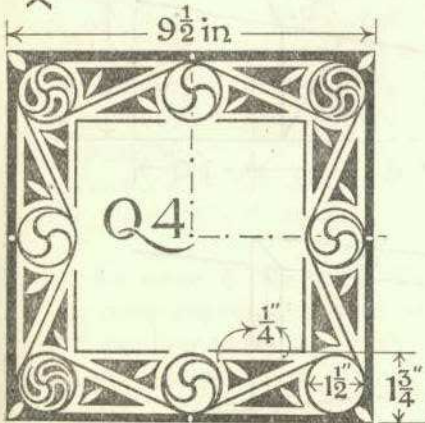

Q5.



BOYS ONLY.

Q1.

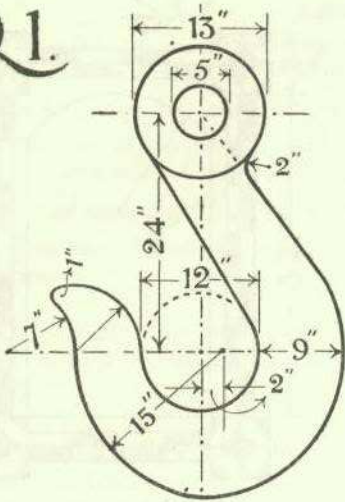

Q2.

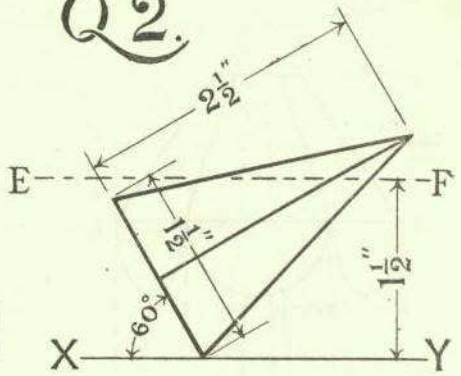

Q3.

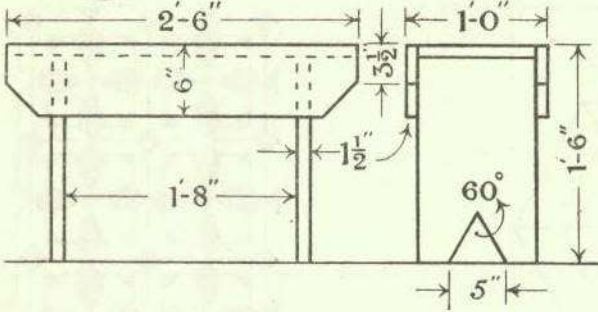

Q4.

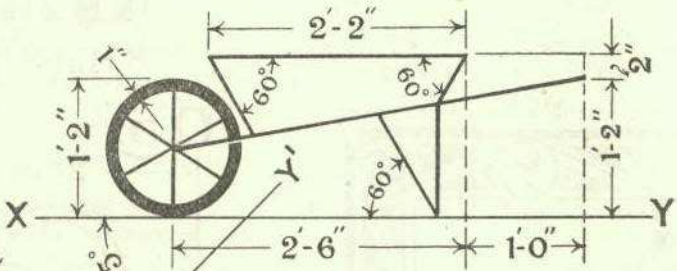
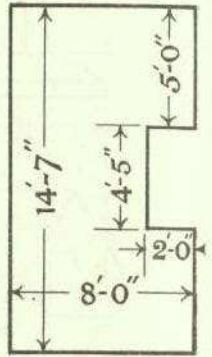

Q5.

