



A JUNIOR CERTIFICATE EXAMINATION, 2000
 TECHNICAL GRAPHICS — HIGHER LEVEL
 THURSDAY 15 JUNE — MORNING, 9.30 - 12.30
 TOTAL MARKS 400 (Sections A and B)

Examination Number 	Centre Stamp 
---	---

INSTRUCTIONS

- (a) Answer **any twelve** of the short answer questions in Section A (120 marks) using the spaces provided. All questions in Section A carry equal marks.
- (b) Answer **any four** of the six questions in Section B (280 marks). All questions in Section B carry equal marks.
- (c) Examination Number must be distinctly marked **in the space provided above** and on each sheet of paper used.
- (d) All construction lines must be clearly shown.
- (e) All measurements are in millimetres.
- (f) Hand up this answer book (Section A) at the end of the examination.

For Examiner's Use Only	
QUESTION	MARK
Section A (Total)	
Section B Q1	
Q2	
Q3	
Q4	
Q5	
Q6	
TOTAL \Rightarrow	
GRADE \Rightarrow	

WARNING

**THIS ANSWERBOOK MUST BE HANDED UP
 AT THE END OF THE EXAMINATION
 OTHERWISE MARKS WILL BE LOST.**

1. Correctly fill in the labels for each of the diagrams by selecting from the table shown.

TABLE				
Hypotenuse	120°	Secant	Acute Angle	π

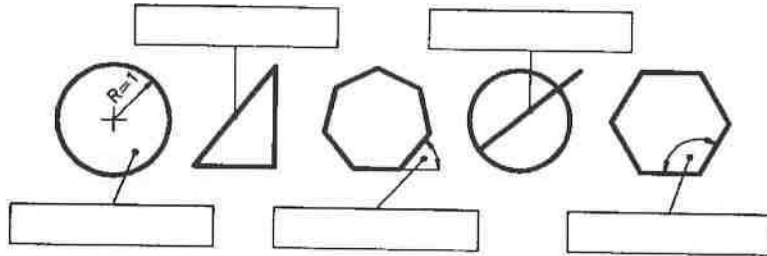

2. The figure shown on the left is to be enlarged to twice its original size. Draw this figure twice full size on the enlarged grid.

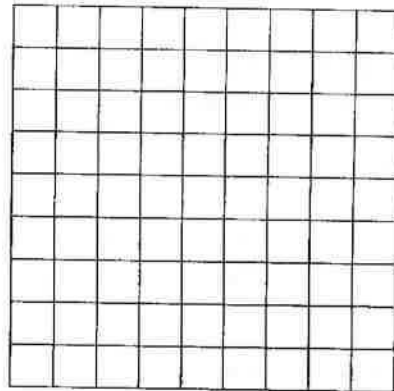
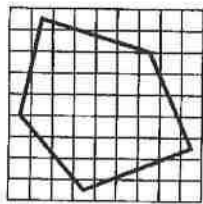

3. Using a CAD facility two lines were drawn as recorded by the following command sequences at (a) and (b). Indicate on the diagram below the resultant lines.

(Note: Axes marked at intervals of 10)

(a) **Command:** Line

From point: 0,0

To point: 30,20

To point: ↵

(b) **Command:** Line

From point: 40,40

To point: @50<270

To point: ↵

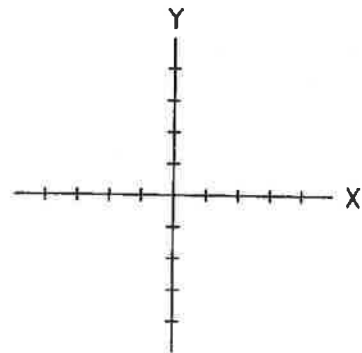

4. Fill in the blanks below:-

- (a) Distance A is _____ metres.
- (b) Distance B is _____ metres.

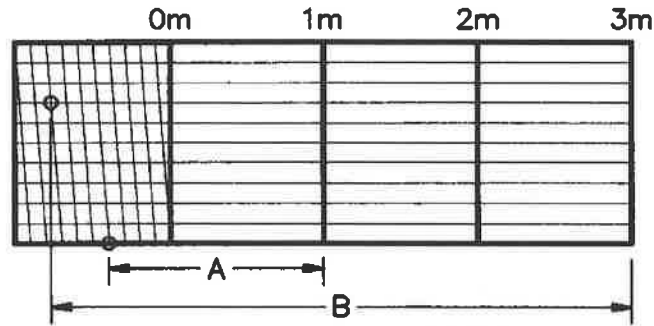

5. A parabola is to be inscribed in the rectangle ABCD. The position of the vertex is indicated by the point V. Determine the position of a point P on the curve which will lie on the line VE.

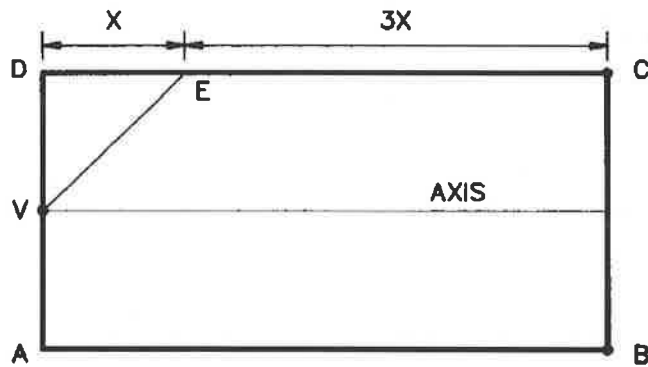

6. Complete the end view.

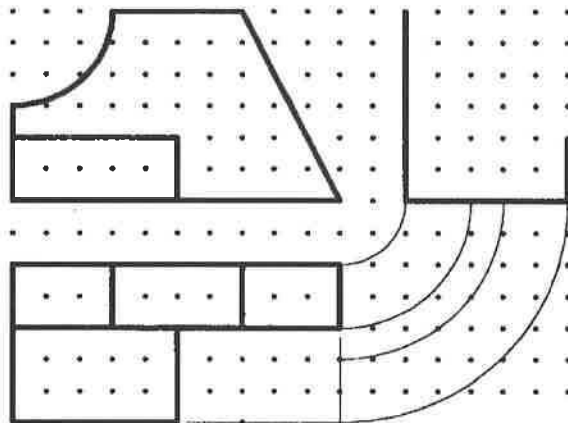

7. Describe a circle of radius 25 to touch the given line L and circle K. Show clearly the necessary construction and points of contact.

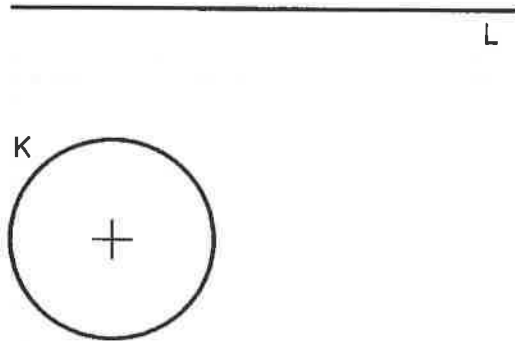

8. Complete the isometric sketch.

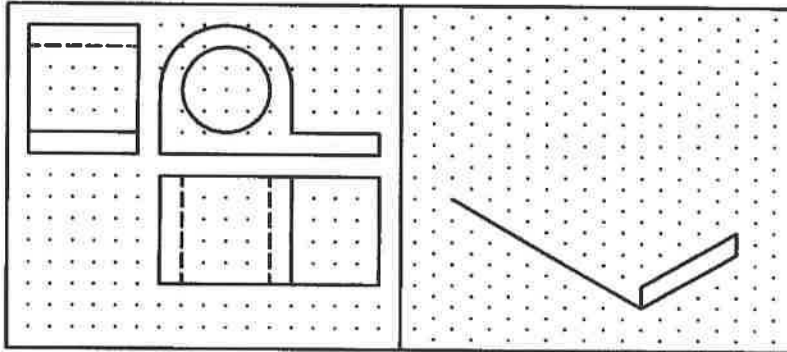

9. Shown is the elevation and auxiliary elevation of a structure. Project the plan below the given X - Y line.

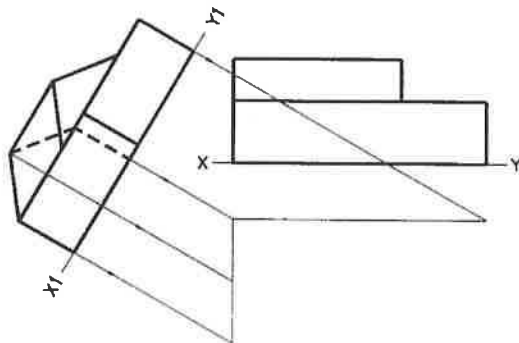

10. Shown is the elevation and end view of a clock.

- (a) Make a freehand pictorial sketch of the clock in the space provided.
- (b) Apply appropriate shading.

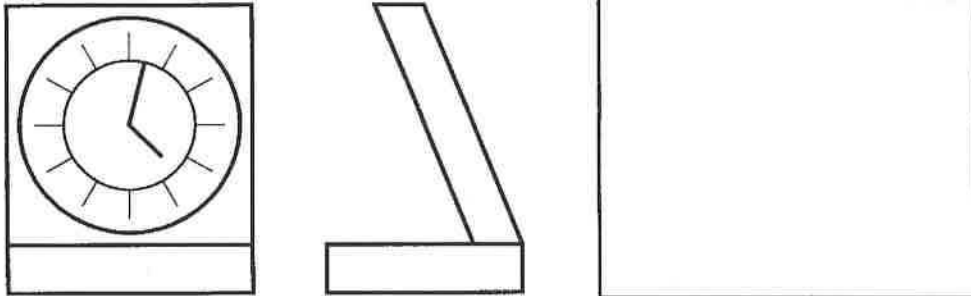

11. Shown is the elevation and plan of a hemisphere. Also shown in plan is the position of a point P on the surface. Locate P in the elevation.

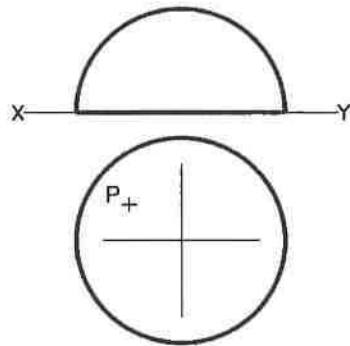

12. Shown are the orthographic views of a container. The container is open at the top. Draw the surface development of the container.

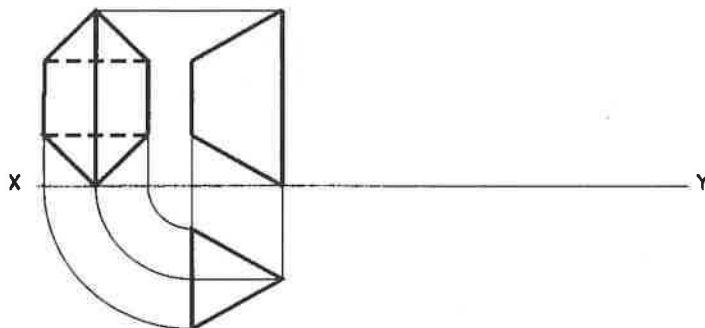

13. Determine, using an appropriate method, which of the two figures shown below contains the greater area. Hence complete the following sentence by filling in the blank:-

The figure _____ has the greater area.

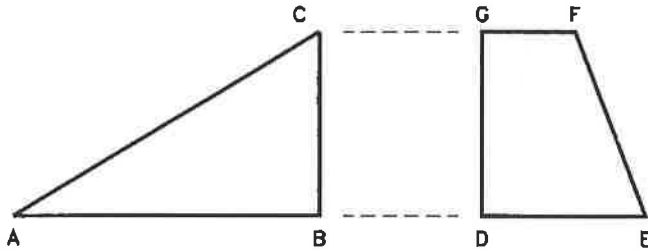

14. The figure shown is subjected to a rotation about point P in a clockwise direction. The angle of rotation is 100° . Draw the resulting image.

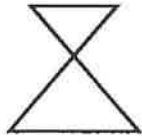

P \oplus

15. The end view and plan of an object are shown. Project the front elevation.

