



**Coimisiún na Scrúduithe Stáit**  
**State Examinations Commission**

---

**LEAVING CERTIFICATE EXAMINATION, 2003**

---

**PHYSICS – HIGHER LEVEL**

---

**MONDAY, 16 JUNE – MORNING 9.30 TO 12.30**

---

Answer **three** questions from **section A** and **five** questions from **section B**.

## SECTION A (120 marks)

Answer **three** questions from this section.

Each question carries 40 marks.

---

1. In an experiment to verify Boyle's law, a student measured the volume  $V$  of a gas at different values of the pressure  $p$ . The mass of the gas was not allowed to change and its temperature was kept constant.

The table shows the data recorded by the student.

$p/\text{kPa}$	120	180	220	280	320	380	440
$V/\text{cm}^3$	9.0	6.0	5.0	4.0	3.5	3.0	2.5

Describe with the aid of a diagram how the student obtained this data. (12)

Draw a suitable graph on graph paper to show the relationship between the pressure of the gas and its volume. (15)

Explain how your graph verifies Boyle's law. (6)

Describe how the student ensured that the temperature of the gas was kept constant. (7)

2. In an experiment to measure the specific latent heat of vaporisation of water, cold water was placed in a copper calorimeter. Steam was passed into the cold water until a suitable rise in temperature was achieved. The following results were obtained.

Mass of the calorimeter .....	= 73.4 g
Mass of cold water .....	= 67.5 g
Initial temperature of water .....	= 10 °C
Temperature of the steam.....	= 100 °C
Mass of steam added .....	= 1.1 g
Final temperature of water .....	= 19 °C

Describe how the mass of the steam was found. (9)

Using the data, calculate a value for the specific latent heat of vaporisation of water. The specific heat capacity of copper is  $390 \text{ J kg}^{-1} \text{ K}^{-1}$  and the specific heat capacity of water is  $4180 \text{ J kg}^{-1} \text{ K}^{-1}$ . (18)

Why is the rise in temperature the least accurate value? Give two ways of improving the accuracy of this value. (13)

3. The following is part of a student's report of an experiment to measure the focal length of a converging lens.

"I found the approximate focal length of the lens to be 15 cm. I then placed an object at different positions in front of the lens so that a real image was formed in each case."

The table shows the measurements recorded by the student for the object distance  $u$  and the image distance  $v$ .

$u/\text{cm}$	20.0	25.0	35.0	45.0
$v/\text{cm}$	66.4	40.6	27.6	23.2

How did the student find an approximate value for the focal length of the lens? (6)

Describe, with the aid of a labelled diagram, how the student found the position of the image. (10)

Using the data in the table, find an average value for the focal length of the lens. (15)

Give two sources of error in measuring the image distance and state how one of these errors can be reduced. (9)

4. In an experiment to verify Joule's law, a heating coil was placed in a fixed mass of water. The temperature rise  $\Delta\theta$  produced for different values of the current  $I$  passed through the coil was recorded. In each case the current was allowed to flow for a fixed length of time.

The table shows the recorded data.

$I/\text{A}$	1.5	2.0	2.5	3.0	3.5	4.0	4.5
$\Delta\theta/^\circ\text{C}$	3.5	7.0	10.8	15.0	21.2	27.5	33.0

Describe, with the aid of a labelled diagram, how the apparatus was arranged in this experiment. (12)

Using the given data, draw a suitable graph on graph paper and explain how your graph verifies Joule's law. (18)

Explain why the current was allowed to flow for a fixed length of time in each case. (5)

Apart from using insulation, give one other way of reducing heat losses in the experiment. (5)

## SECTION B (280 marks)

Answer **five** questions from this section.  
Each question carries 56 marks.

---

5. Answer any **eight** of the following parts (a), (b), (c), etc.

(a) State Hooke's law. (7)

(b) What is the relationship between the acceleration due to gravity  $g$  and the distance from the centre of the earth? (7)

(c) The diagram shows forces of 5 N applied to a water tap. Calculate the moment of the couple (torque) on the tap. (7)

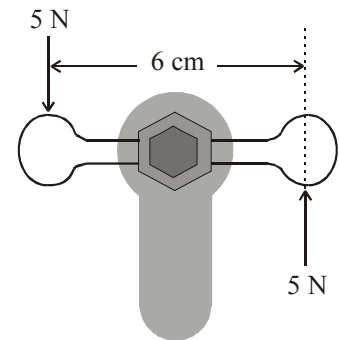

(d) Which wave phenomenon can be used to distinguish between transverse waves and longitudinal waves? (7)

(e) Sound intensity level can be measured in dB or dB(A). What is the difference between the two scales? (7)

(f) Calculate the critical angle for diamond. The refractive index of diamond is 2.4. (7)

(g) What is the purpose of a miniature circuit breaker (MCB) in an electric circuit? (7)

(h) What is the photoelectric effect? (7)

(i) What is meant by nuclear fusion? (7)

(j) Give one contribution made to Physics by **either** Paul Dirac **or** Nicholas Callan. (7)

6. Give the difference between vector quantities and scalar quantities and give one example of each. (8)

Describe an experiment to find the resultant of two vectors. (18)

A cyclist travels from A to B along the arc of a circle of radius 25 m as shown. Calculate (i) the distance travelled, (ii) the displacement undergone, by the cyclist. (12)

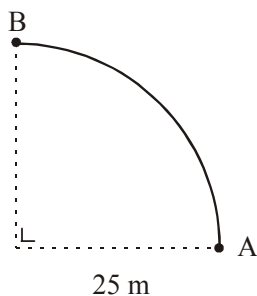

A person in a wheelchair is moving up a ramp at a constant speed. Their total weight is 900 N. The ramp makes an angle of  $10^\circ$  with the horizontal. Calculate the force required to keep the wheelchair moving at a constant speed up the ramp. (9)  
(You may ignore the effects of friction.)

The ramp is 5 m long. Calculate the power exerted by the person in the wheelchair if it takes her 10 s to travel up the ramp. (9)

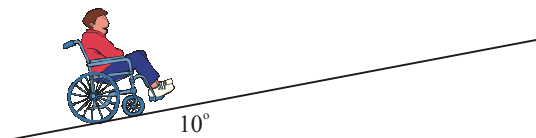

7. Describe an experiment to show that sound is a wave motion. (12)

What is the Doppler effect? Explain, with the aid of labelled diagrams, how this phenomenon occurs. (14)

Bats use high frequency waves to detect obstacles. A bat emits a wave of frequency 68 kHz and wavelength 5.0 mm towards the wall of a cave. It detects the reflected wave 20 ms later. Calculate the speed of the wave and the distance of the bat from the wall. (12)

If the frequency of the reflected wave is 70 kHz, what is the speed of the bat towards the wall? (12)

Give two other applications of the Doppler effect. (6)

8. Define the unit of current, i.e. the ampere. (9)

Describe an experiment to demonstrate the principle on which the definition of the ampere is based. (15)

Various materials conduct electricity. Draw a graph to show the relationship between current and voltage for each of the following conductors:

- (i) a metal at constant temperature
- (ii) an ionic solution with inactive electrodes
- (iii) a gas. (18)

How would the graph for the metal differ if its temperature were increasing? (7)

How would the graph for the ionic solution differ if its concentration were reduced? (7)

9. List two properties of the electron. (6)

Name the Irishman who gave the electron its name in the nineteenth century. (6)

Give an expression for the force acting on a charge  $q$  moving at a velocity  $v$  at right angles to a magnetic field of flux density  $B$ . (6)

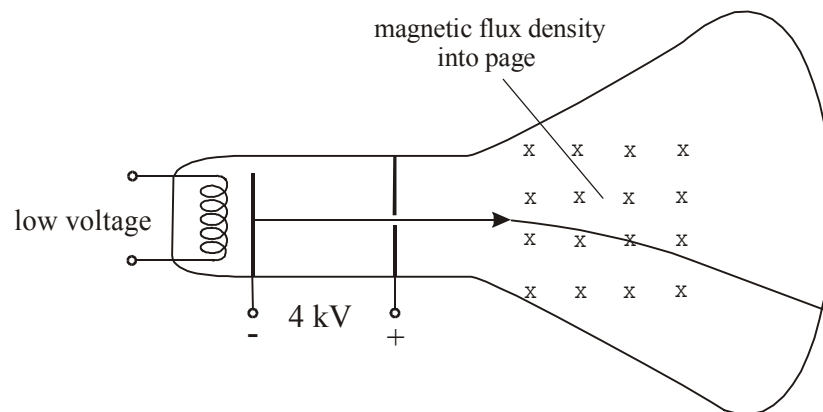

An electron is emitted from the cathode and accelerated through a potential difference of 4 kV in a cathode ray tube (CRT) as shown in the diagram.

How much energy does the electron gain? What is the speed of the electron at the anode? (Assume that the speed of the electron leaving the cathode is negligible.) (18)

After leaving the anode, the electron travels at a constant speed and enters a magnetic field at right angles, where it is deflected. The flux density of the magnetic field is  $5 \times 10^{-2}$  T.

Calculate (i) the force acting on the electron, (ii) the radius of the circular path followed by the electron, in the magnetic field. (15)

What happens to the energy of the electron when it hits the screen of the CRT? (5)

(mass of electron =  $9.1 \times 10^{-31}$  kg; charge on electron =  $1.6 \times 10^{-19}$  C)

10. Answer **either** part (a) or part (b).

- (a) Leptons, baryons and mesons belong to the “particle zoo”.  
Give (i) an example, (ii) a property, of each of these particles. (18)

The following reaction represents pair production.

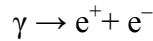

Calculate the minimum frequency of the  $\gamma$ -ray photon required for this reaction to occur. (15)

What is the effect on the products of the reaction if the frequency of the  $\gamma$ -ray photon exceeds the minimum value? (5)

The reverse of the above reaction is known as pair annihilation. Write a reaction that represents pair annihilation. (6)

Explain how the principle of conservation of charge and the principle of conservation of momentum apply in pair annihilation. (12)

(mass of electron =  $9.1 \times 10^{-31}$  kg; speed of light,  $c = 3.0 \times 10^8$  m s<sup>-1</sup> ;  
Planck constant,  $h = 6.6 \times 10^{-34}$  J s)

- (b) Explain the difference between intrinsic and extrinsic conduction in semiconductors. (12)

Draw a labelled diagram of a p-n junction. (9)

Explain how a p-n diode can be used to convert a.c. to d.c. (9)

Draw a diagram of a circuit used to get a smooth d.c. output from an a.c. source. (9)

Explain why a light-emitting diode (LED) emits light when a suitable forward bias is applied to it. (9)

Give two ways in which a photodiode differs from a LED and give a use for a photodiode. (8)

11. Read the following passage and answer the accompanying questions.

*Irish Times: Monday, January 11, 1999*

Radioactive decay helps to determine exact dates.

Radioactive decay occurs with such precision that it is often used as a clock. Carbon dating has been invaluable to archaeologists, historians and anthropologists. The method is based on the measurement of  $^{14}\text{C}$ , a radioactive isotope of carbon with a half-life of 5730 years.  $^{14}\text{C}$  occurs to a small extent in the atmosphere together with the much more common  $^{12}\text{C}$ . Living organisms constantly exchange carbon with the atmosphere and the ratio of  $^{14}\text{C}$  to  $^{12}\text{C}$  in living tissue is the same as it is in the atmosphere. This ratio is assumed to have remained the same since prehistoric times. When an organism dies, it stops exchanging carbon with the atmosphere, and its  $^{14}\text{C}$  nuclei keep disintegrating while the  $^{12}\text{C}$  in the dead tissue remains undisturbed.

- (a) What is radioactive decay? (7)
- (b) What is an isotope? (7)
- (c) Apart from “carbon dating”, give two other uses of radioactive isotopes. (7)
- (d) How many neutrons are in a  $^{14}\text{C}$  nucleus? (7)
- (e)  $^{14}\text{C}$  decays to  $^{14}\text{N}$ . Write an equation to represent this nuclear reaction. (7)
- (f) How much of a  $^{14}\text{C}$  sample remains after 11 460 years? (7)
- (g) Calculate the decay constant of  $^{14}\text{C}$ . (7)
- (h) Why does the  $^{12}\text{C}$  in dead tissue remain “undisturbed”? (7)

(Refer to the Periodic Table of the Elements in the Mathematics Tables, p.44.)



12. Answer any **two** of the following parts (a), (b), (c), (d).

(a) State Newton's second law of motion. (6)

A skydiver falls from an aircraft that is flying horizontally. He reaches a constant speed of  $50 \text{ m s}^{-1}$  after falling through a height of 1500 m. Calculate the average vertical acceleration of the skydiver.

If the mass of the skydiver is 90 kg, what is the magnitude and direction of the average resultant force acting on him? (10)

Use a diagram to show the forces acting on the skydiver and explain why he reaches a constant speed. (12)

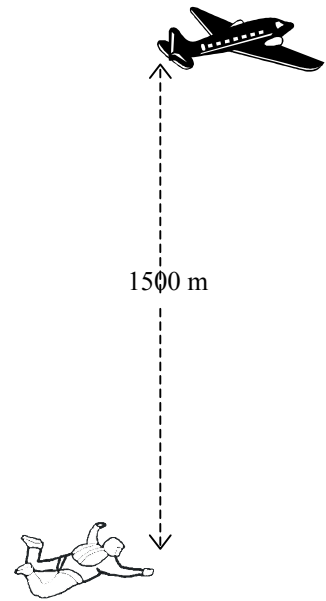

(b) What is the difference between heat and temperature? (6)

The emf of a thermocouple can be used as a thermometric property. Explain the underlined terms. (10)

Name a thermometric property other than emf. Explain why it is necessary to have a standard thermometer. (12)

(c) State Coulomb's law of force between electric charges. (6)

Define electric field strength and give its unit. (9)

How would you demonstrate an electric field pattern? (9)



The diagram shows a negative charge  $-Q$  at a point X. Copy the diagram and show on it the direction of the electric field strength at Y. (4)

(d) State the laws of electromagnetic induction. (12)

A small magnet is attached to a spring as shown in the diagram. The magnet is set oscillating up and down. Describe the current flowing in the circuit. (6)

If the switch at A is open, the magnet will take longer to come to rest. Explain why. (10)

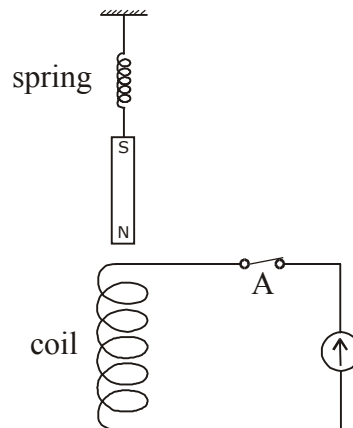

**Blank Page**

**Blank Page**