



**Coimisiún na Scrúduithe Stáit
State Examinations Commission**

LEAVING CERTIFICATE EXAMINATION, 2011

MATHEMATICS – ORDINARY LEVEL

PAPER 2 (300 marks)

MONDAY, 13 JUNE – MORNING, 9:30 to 12:00

Attempt **FIVE** questions from **Section A** and **ONE** question from **Section B**.
Each question carries 50 marks.

WARNING: Marks will be lost if all necessary work is not clearly shown.

**Answers should include the appropriate units of measurement,
where relevant.**

SECTION A
Attempt FIVE questions from this section.

1. (a) (i) Calculate the area of the rectangle shown in the diagram.
- (ii) Hence, calculate the area of the shaded region.

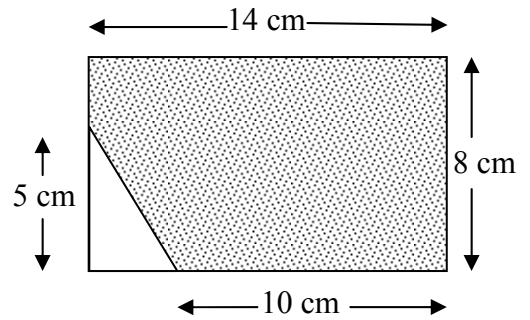

- (b) The sketch shows a section of a wall that is to be painted. At equal intervals of 1.2 m along the bottom of the wall, perpendicular measurements are made to the uneven edge, as shown on the sketch.

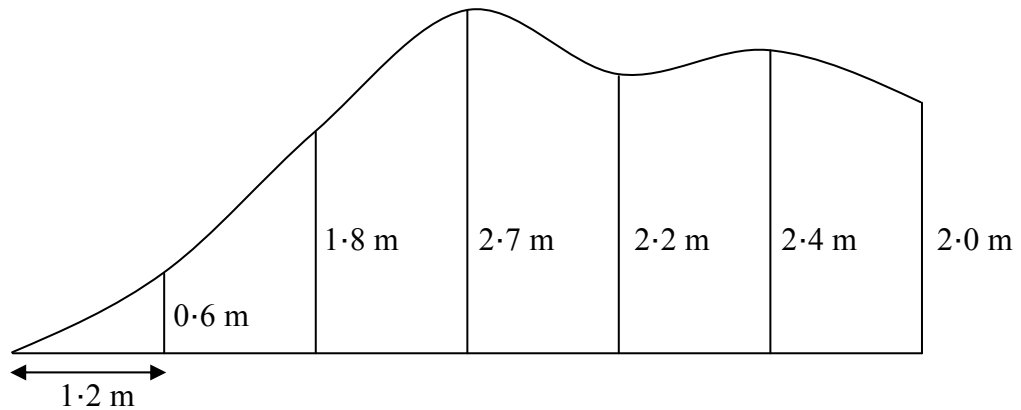

- (i) Use Simpson's rule to estimate the area of the section of the wall.
- (ii) How many litres of paint are required to paint the section of the wall, if 1 litre of paint covers an area of 2.2 m^2 ? Give your answer correct to the nearest litre.
- (c) A solid object consists of a cylinder with hemispherical ends, as shown. The cylinder and hemispheres have the same radius.

The volume of each hemisphere is $144\pi \text{ cm}^3$.

- (i) Find the radius of each hemisphere.
- (ii) The total volume of the object is $720\pi \text{ cm}^3$.

Find d , the length of the object.

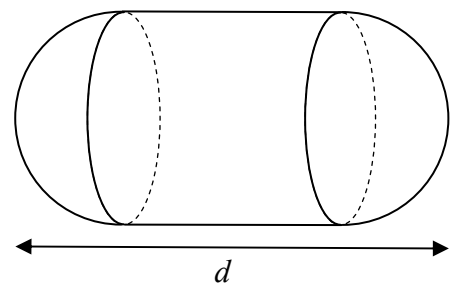

2. (a) Verify that the point $(2, -4)$ is on the line $3x - y = 10$.

(b) $P(2, 8)$, $Q(4, -1)$ and $R(6, 0)$ are three points.

(i) Find the slope of PR .

(ii) Show that PR is perpendicular to RQ .

(iii) Find the equation of RQ .

(iv) Find the co-ordinates of the point at which RQ intersects the y -axis.

(c) $A(-1, -6)$, $B(6, 8)$ and $C(2, 5)$ are three points.

(i) Find the area of the triangle ABC .

(ii) Find the co-ordinates of two possible points D on the x -axis such that
area of triangle $ABD =$ area of triangle ABC .

3. (a) A circle has equation $x^2 + y^2 = 81$.

(i) Write down the co-ordinates of the centre of the circle.

(ii) Find the radius of the circle.

(b) The circle c has equation $(x - 3)^2 + (y + 1)^2 = 17$.

(i) Verify that the point $(7, -2)$ is on c .

(ii) On a co-ordinate diagram, mark the centre of c and draw c .

(iii) Find, using algebra, the co-ordinates of the two points at which c intersects the x -axis.

(c) The points $A(-1, 2)$, $B(-3, -4)$, $C(3, -6)$ and $D(5, 0)$ are the vertices of a square.

The sides of the square are tangents to the circle s , as shown.

(i) Find the co-ordinates of the centre of s .

(ii) Find the equation of s .

(iii) The circle $(x + 4)^2 + y^2 = 10$ is the image of s under the translation $(p, q) \rightarrow (6, 5)$.

Find the value of p and the value of q .

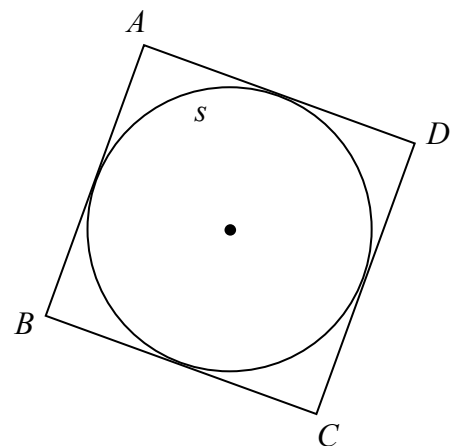

4. (a) In the diagram, the line l passes through the point A and is parallel to BC .

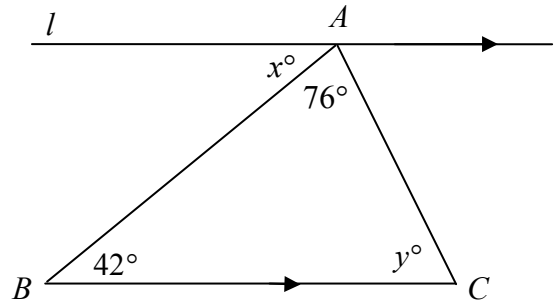

- (i) Find x .
(ii) Find y .

- (b) Prove that the sum of the lengths of any two sides of a triangle is greater than that of the third side.

- (c) The triangle ORS is the image of the triangle OPQ under an enlargement of centre O .
 $|OQ| = 6$, $|QS| = 9$ and $|RS| = 6$.

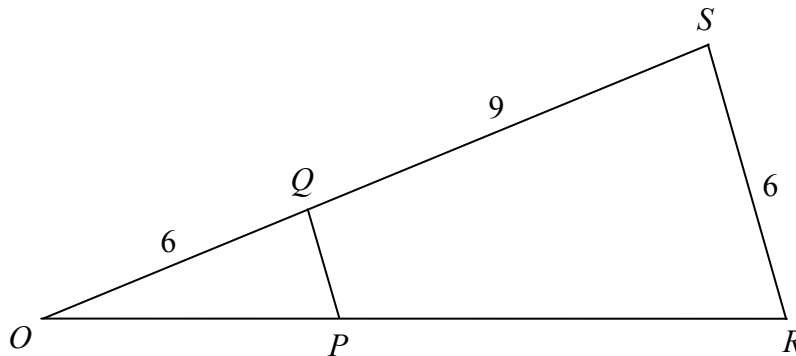

- (i) Find the scale factor of the enlargement.
(ii) Find $|PQ|$.
(iii) Given that the area of the triangle OPQ is 7.2 square units, find the area of the triangle ORS .
(iv) Find the area of the quadrilateral $PRSQ$.

5. (a) Use the sine rule to calculate the value of x in the diagram.
Give your answer correct to the nearest integer.

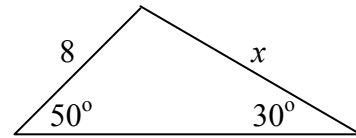

- (b) In the triangle ABC , $|BC| = 6$ cm, $|\angle ABC| = 90^\circ$,
 $|\angle CAB| = \theta$ and $\sin \theta = \frac{3}{5}$.

(i) Find $|AC|$.

(ii) Find $|AB|$.

(iii) Verify that $\cos^2 \theta + \sin^2 \theta = 1$.

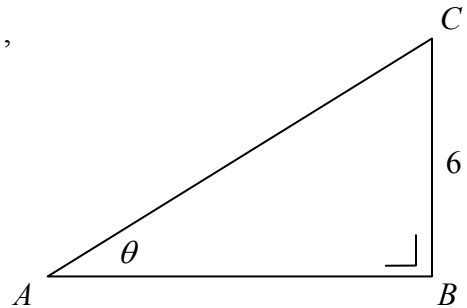

- (c) $PQRS$ is a quadrilateral with diagonal $[SQ]$.

$|RS| = 62$, $|SQ| = 35$, $|\angle SQR| = 82^\circ$, $|\angle SPQ| = 60^\circ$, $|SP| = 3x$ and $|PQ| = 8x$.

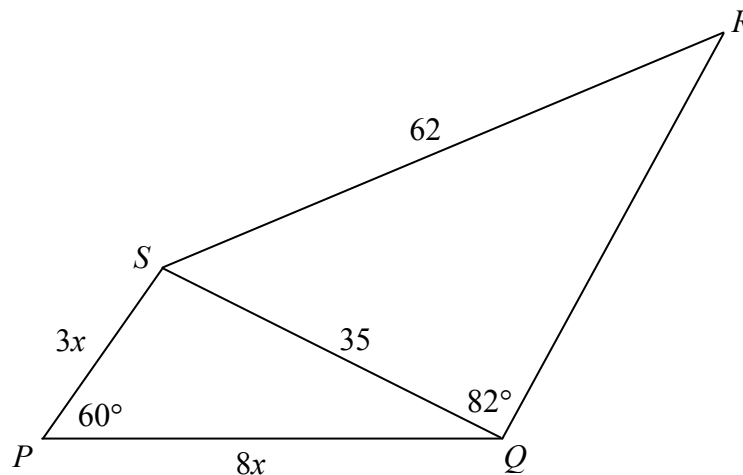

- (i) Find $|\angle QRS|$, correct to the nearest degree, given that $0^\circ \leq |\angle QRS| \leq 90^\circ$.
- (ii) Find the value of x .

6. (a) (i) Find $4!$

(ii) Simplify $\frac{6(5!)}{5(4!)}$.

(b) The letters in the word FERMAT are arranged taking all of the letters each time.

How many different arrangements are possible if

(i) there are no restrictions

(ii) the arrangements begin with the letter F

(iii) the arrangements begin with the letter F and end with a vowel

(iv) the two vowels are together?

(c) The table below shows how the students in a school usually travel to school.

	Walk	Cycle	Other
Boys	157	123	166
Girls	184	91	172

(i) A student is picked at random.
What is the probability that the student is a boy?

(ii) A student is picked at random.
What is the probability that the student walks to school?

(iii) A boy is picked at random.
What is the probability that he cycles to school?

(iv) A girl is picked at random.
What is the probability that she does not walk to school?

7. (a) Calculate the mean of the numbers 8, 6, 1, 3, 7, 8, 2.

(b) An information evening was held at a school. The number of people who entered the school during 20 minute intervals, beginning at 18:00, is given in the following table:

Time	18:00 - 18:20	18:20 - 18:40	18:40 - 19:00	19:00 - 19:20	19:20 - 19:40	19:40 - 20:00
Number of people	35	55	190	140	110	70

[Note: 18:20 - 18:40 means 18:20 or later, but before 18:40, etc.]

(i) Copy and complete the following cumulative frequency table:

Time	Before 18:20	Before 18:40	Before 19:00	Before 19:20	Before 19:40	Before 20:00
Number of people						

(ii) Draw the cumulative frequency curve (ogive).

(iii) Use your curve to estimate the interquartile range.

(c) The histogram represents the marks obtained by candidates in an examination.

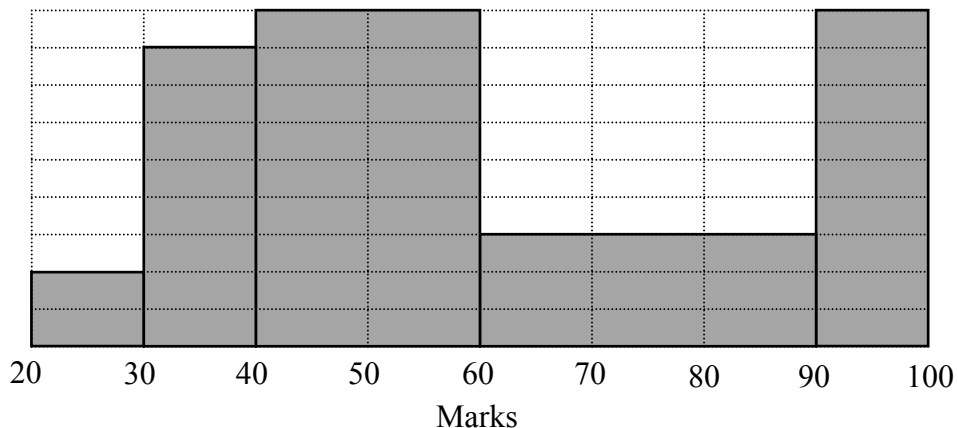

(i) Copy and complete the following frequency table:

Marks	20 - 30	30 - 40	40 - 60	60 - 90	90 - 100
Number of candidates	4				

(ii) The mean mark was 60. Taking the mid-interval values of the completed frequency table, find the standard deviation, correct to the nearest integer.

(iii) Find the maximum possible number of candidates whose marks were within one standard deviation of the mean.

SECTION B
Attempt ONE question from this section.

8. (a) The points P, Q, R and S lie on a circle, centre O .
 $|\angle SPQ| = 65^\circ$.

- (i) Find the value of x .
(ii) Find the value of y .

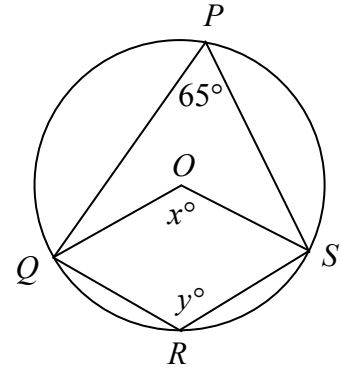

- (b) Prove that if $[AB]$ and $[CD]$ are chords of a circle and the lines AB and CD meet at the point K , where K is inside the circle, then $|AK| \cdot |KB| = |CK| \cdot |KD|$.

- (c) The line QS is a tangent to the circle c .
 $[RS]$ is a diameter of the circle.
 $[QR]$ cuts the circle at P .
 $|QP| = 8$ and $|QS| = 4\sqrt{5}$.

- (i) Calculate $|RP|$.
(ii) Hence, calculate $|RS|$ and give your answer in the form $a\sqrt{b}$, where $a, b \in \mathbb{N}$ and $a > 1$.

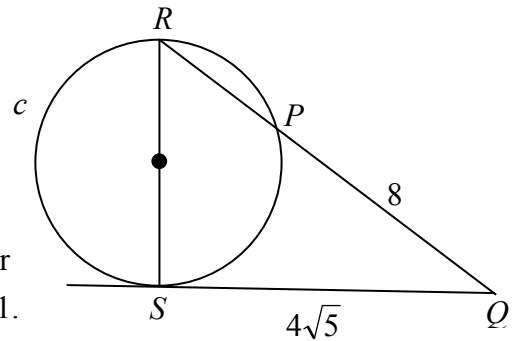

9. (a) $\overrightarrow{OM} = 3\vec{i} - 4\vec{j}$ and $\overrightarrow{ON} = \vec{i} + 2\vec{j}$, where O is the origin.
Plot the points M and N on a co-ordinate diagram.

- (b) $\overrightarrow{OP} = 5\vec{i} + 3\vec{j}$ and $\overrightarrow{OQ} = -4\vec{i} + \vec{j}$, where O is the origin.

- (i) Express $2\overrightarrow{OP} - \overrightarrow{OQ}$ in terms of \vec{i} and \vec{j} .
(ii) Express \overrightarrow{PQ} in terms of \vec{i} and \vec{j} .
(iii) Find the real numbers k and t such that $k\overrightarrow{OP} + t\overrightarrow{OQ} = 6\vec{i} + 7\vec{j}$.

- (c) $OABC$ is a parallelogram.
 X is a point on $[CB]$ such that $|CX| : |XB| = 2 : 1$.
 Y is the mid-point of $[AB]$.

Express, in terms of \overrightarrow{OA} and \overrightarrow{OC} ,

- (i) \overrightarrow{OB} ,
(ii) \overrightarrow{OX} ,
(iii) \overrightarrow{OY} ,
(iv) \overrightarrow{XY} .

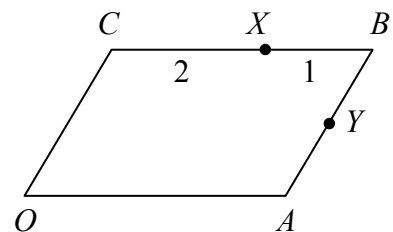

10. (a) (i) Write out the first three terms in the expansion of $(1+x)^4$ in ascending powers of x .
- (ii) Calculate the value of the third term when $x = 0.2$.
- (b) (i) Find S , the sum to infinity of the geometric series $1 + \frac{1}{2} + \frac{1}{4} + \frac{1}{8} + \dots$
- (ii) The sum to infinity of another geometric series is also S .
The common ratio of the series is 0.4 .
Find the first term.
- (c) (i) Equipment costing €15 000 depreciates at the compound rate of 12% per annum. Find the value of the equipment at the end of seven years, correct to the nearest euro.
- (ii) A company invests €15 000 in equipment at the beginning of each year for seven consecutive years. The equipment depreciates at the compound rate of 12% per annum.
- Using the formula for the sum of the first n terms of a geometric series, find the total value of the machinery at the end of the seven years, correct to the nearest euro.

11. (a) The diagram shows the lines $l: 2x + 3y - 6 = 0$,
 $h: x - 3 = 0$ and $k: y - 2 = 0$.

Write down the three inequalities that together define the shaded region in the diagram.

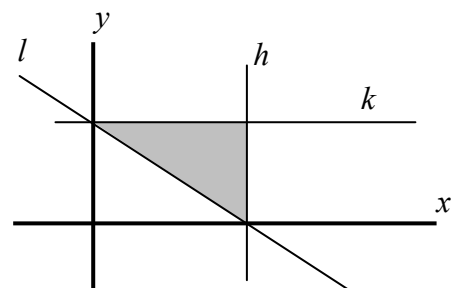

- (b) A garage is starting a van rental business. The garage will rent out two types of vans, small vans and large vans.

To set up the business, each small van costs €20 000 and each large van costs €40 000. The garage has at most €800 000 to purchase the vans.

Each small van requires 18 m^2 of parking space and each large van requires 24 m^2 of parking space. The garage has at most 576 m^2 of parking space available for the vans.

- (i) Taking x as the number of small vans and y as the number of large vans, write down two inequalities in x and y and illustrate these on graph paper.
- (ii) The garage charges €40 a day to rent a small van and €50 a day to rent a large van. How many of each should the garage rent to maximise rental income, assuming that all vans are rented.
- (iii) The garage incurs daily expenses of €12 for each van. Calculate the maximum daily profit from renting the vans.

Blank Page

Blank Page

Blank Page