



Coimisiún na Scrúduithe Stáit
State Examinations Commission

Leaving Certificate Examination
Sample Paper

Applied Mathematics
Higher Level

2 hours and 30 minutes

400 marks

Examination Number

<input type="text"/>	<input type="text"/>	<input type="text"/>	<input type="text"/>	<input type="text"/>	<input type="text"/>
----------------------	----------------------	----------------------	----------------------	----------------------	----------------------

Day and Month of Birth

<input type="text"/>	<input type="text"/>	<input type="text"/>	<input type="text"/>
----------------------	----------------------	----------------------	----------------------

For example, 3rd February
is entered as 0302

Centre Stamp



Instructions

There are eight questions on this paper. **Answer all questions.**

Write your Examination Number in the box on the front cover.

Write your answers in blue or black pen. You may use pencil in graphs and diagrams only.

This examination booklet will be scanned and your work will be presented to an examiner on screen. All of your work should be presented in the answer areas, or on the given graphs, networks or other diagrams. Anything that you write outside of these areas may not be seen by the examiner.

Write all answers into this booklet. There is space for extra work at the back of the booklet. If you need to use it, label any extra work clearly with the question number and part.

The superintendent will give you a copy of the *Formulae and Tables* booklet. You must return it at the end of the examination. You are not allowed to bring your own copy into the examination.

You may lose marks if your solutions do not include relevant supporting work.

You may lose marks if the appropriate units of measurement are not included, where relevant.

You may lose marks if your answers are not given in their simplest form, where relevant.

Diagrams are generally not drawn to scale.

Unless otherwise indicated, take the value of g , the acceleration due to gravity, to be 9.8 m s^{-2} .

Unless otherwise indicated, \vec{i} and \vec{j} are unit perpendicular vectors in the horizontal and vertical directions, respectively, or eastwards and northwards, respectively, as appropriate to the question.

Write the make and model of your calculator(s) here:

Question 1

(a) A directed graph is represented by the adjacency matrix $M = \begin{pmatrix} 0 & 0 & 2 \\ 1 & 1 & 0 \\ 0 & 1 & 0 \end{pmatrix}$.

(i) Draw the graph represented by M .

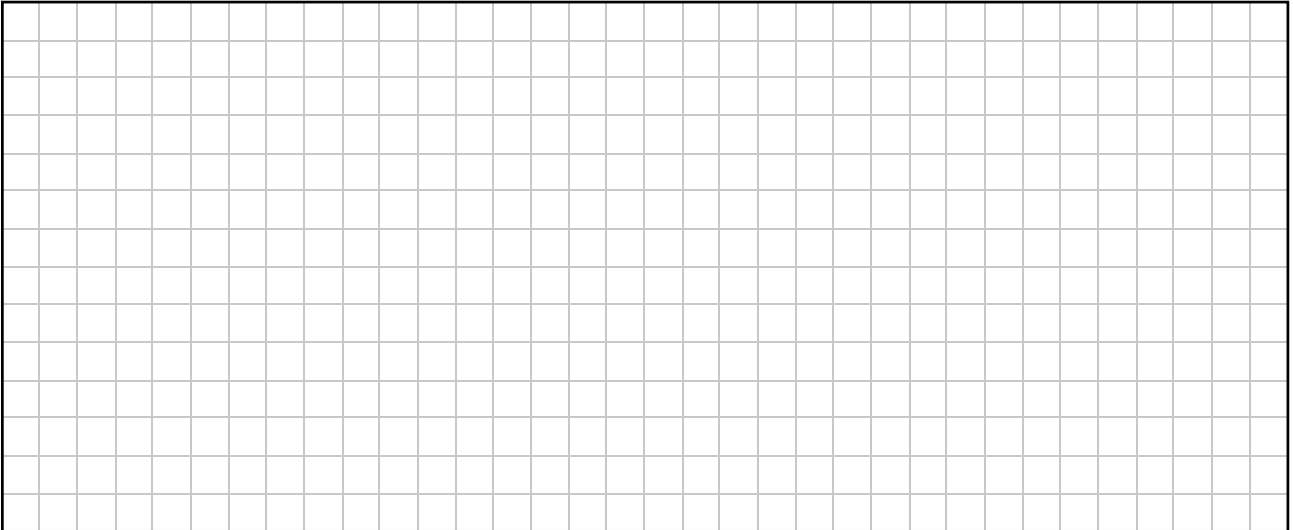

(ii) Calculate M^2 .

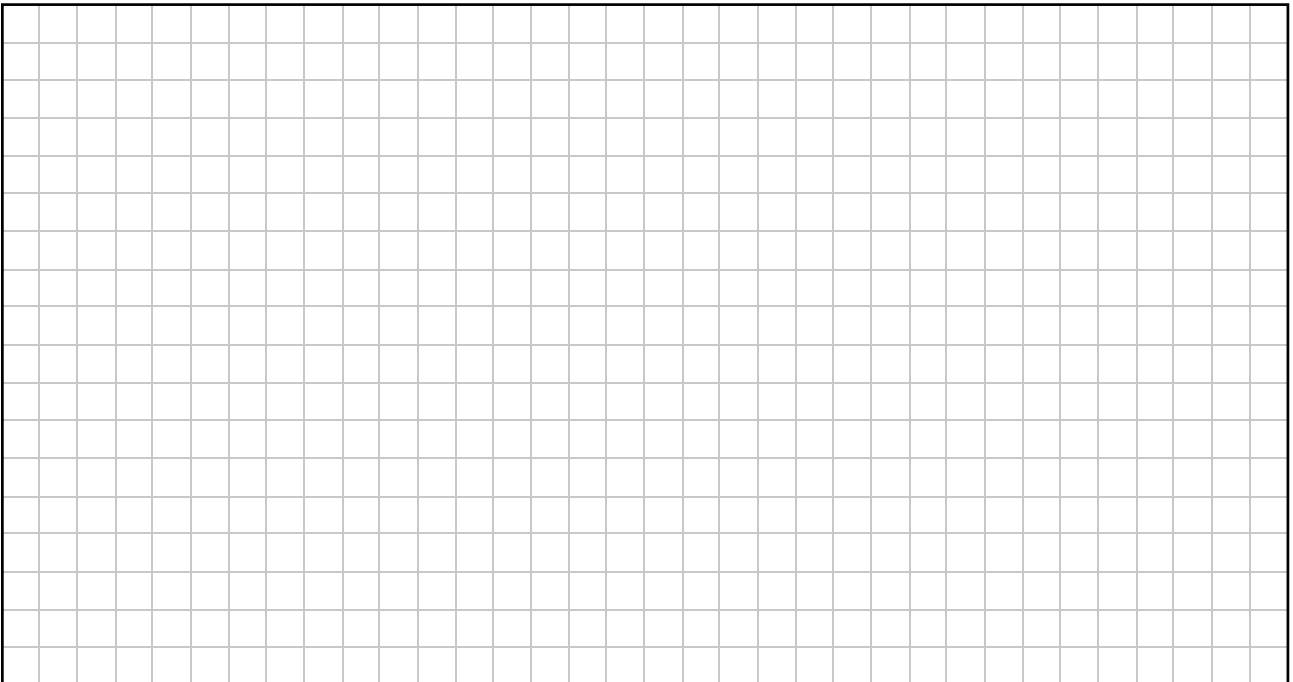

(iii) What information is provided by the elements of M^2 ?

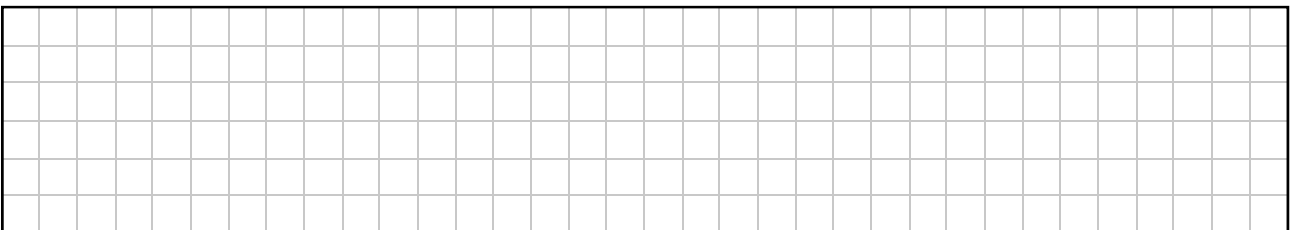

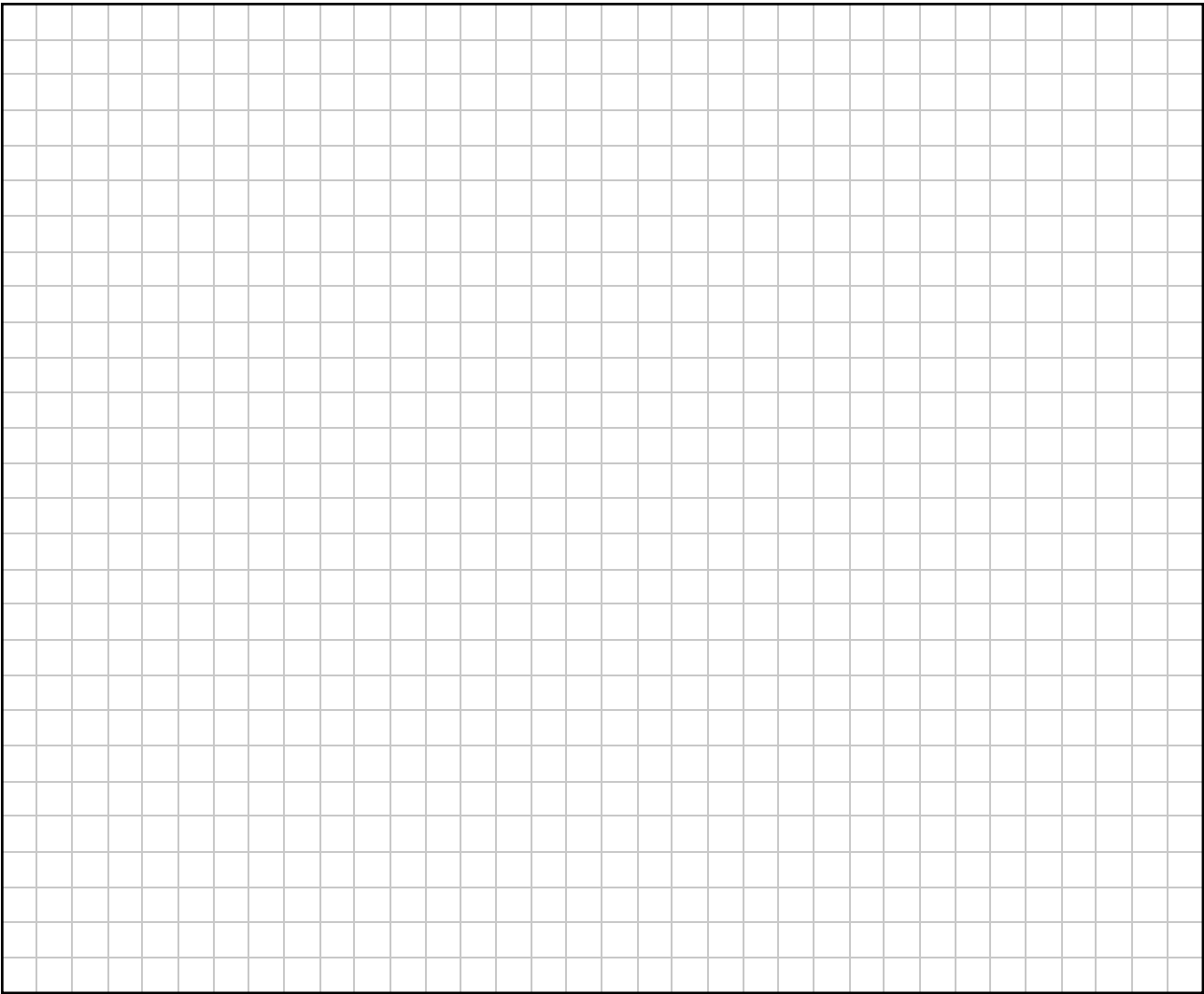

(iv) Plants must be cut back regularly to allow them room to grow. How many of the old branches should be removed at the end of year 4 to ensure that there are exactly 14 branches at the end of year 5?

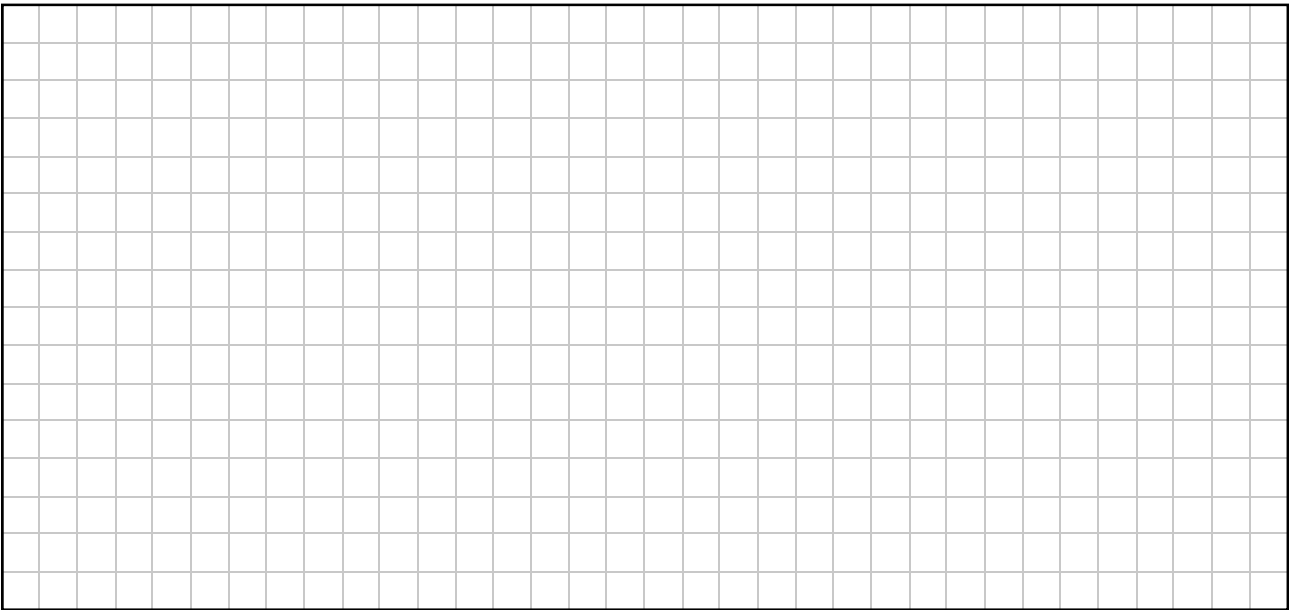

Question 2

The diagram below shows the scheduling network for a project to manufacture a new chemical compound. The network provides some information about the relationships between the twelve activities that have to be completed as part of the project.

The edges of the network represent these activities and are labelled with the letters A to L . The unlabelled edges (shown with dashed lines) do not represent real activities but they help explain the order in which the activities must happen. The letters used to label the edges should **not** be taken as representing the order in which the activities happen.

The nodes of the network represent events or points in time during the project. The source node is the time when the project begins and the sink node is the time when the project ends.

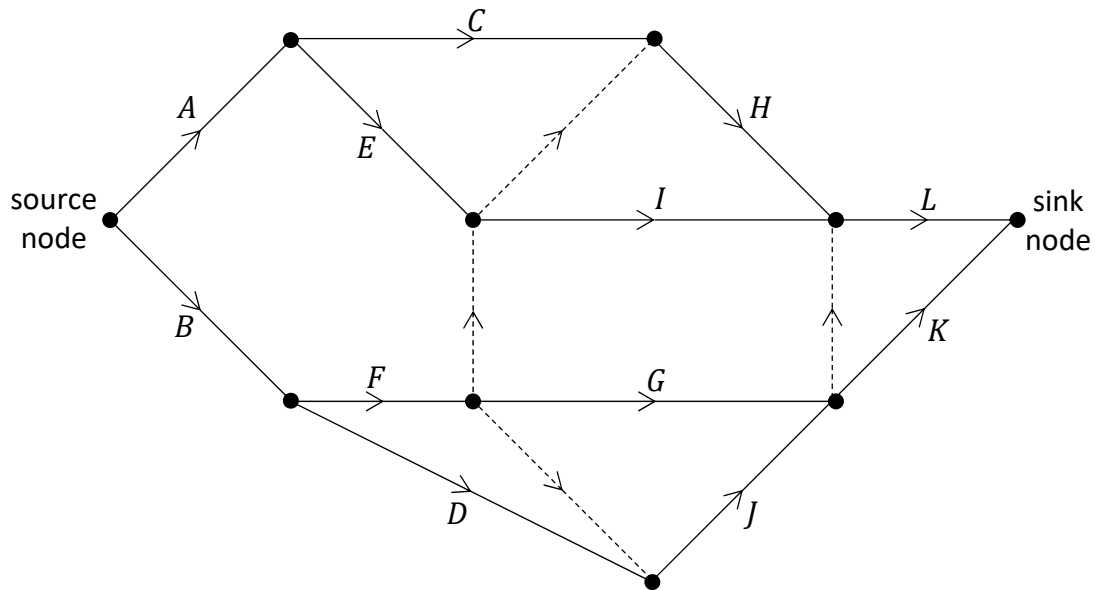

- (i) Complete the table on the next page by listing, for each activity, the other activities on which it depends directly. That is, for each activity $X \in \{C, D, E, \dots, L\}$, write the smallest possible list of other activities which need to be completed before activity X can begin.

Activities A and B do not depend on any prior activities, so the list is empty for these activities, as shown.

Use the space below to show relevant supporting work, if necessary.

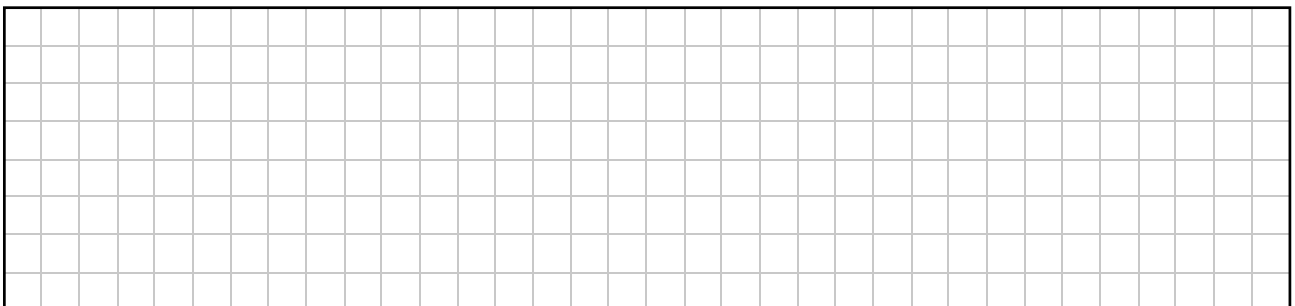

Activity	Depends directly on ...
<i>A</i>	–
<i>B</i>	–
<i>C</i>	
<i>D</i>	
<i>E</i>	
<i>F</i>	
<i>G</i>	
<i>H</i>	
<i>I</i>	
<i>J</i>	
<i>K</i>	
<i>L</i>	

For each of the statements in parts (ii) and (iii) below, state whether you agree or disagree with the statement. Use the scheduling network and/or your answer to part (i) to justify your answer in each case.

(ii) Activity *D* must be completed before activity *G*.

(iii) Activity *E* must be completed before activity *H*.

The time, in days, to complete each of the activities A to L is given in the table below and has also been included in the network redrawn on this page.

Activity	A	B	C	D	E	F	G	H	I	J	K	L
Time (days)	5	3	6	9	4	2	8	4	11	2	7	5

(iv) Calculate the early time and the late time for each event.

Complete the diagram below by writing the early time (upper box) and late time (lower box) at the node representing each event.

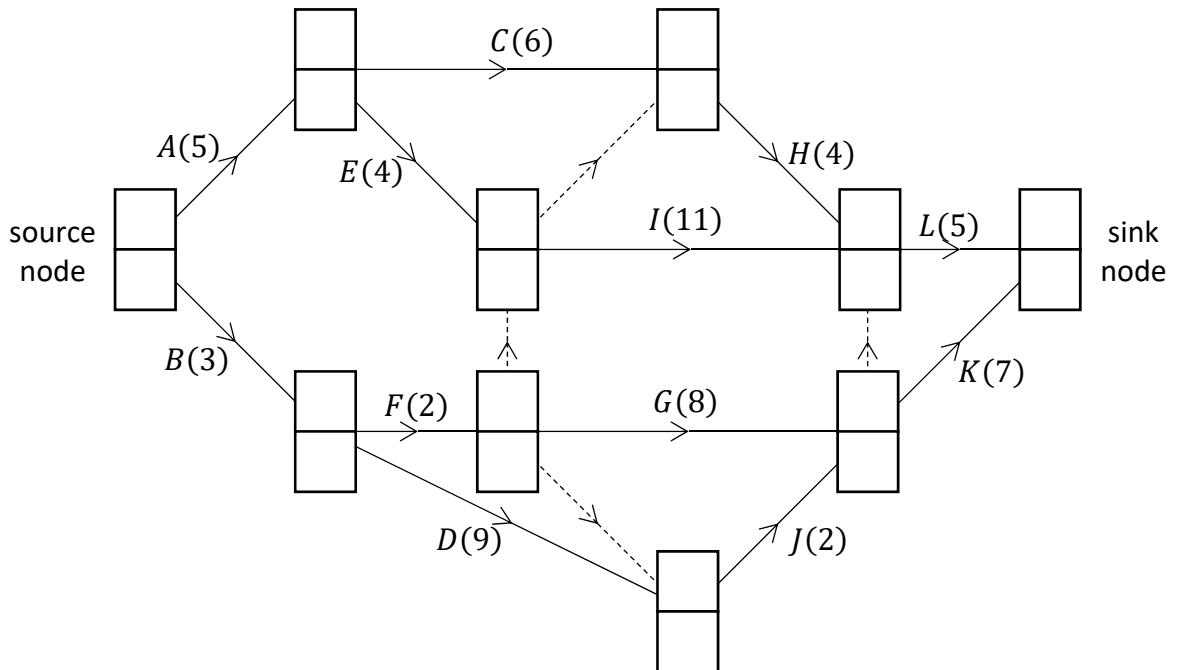

Use the space below to show relevant supporting work, if necessary.

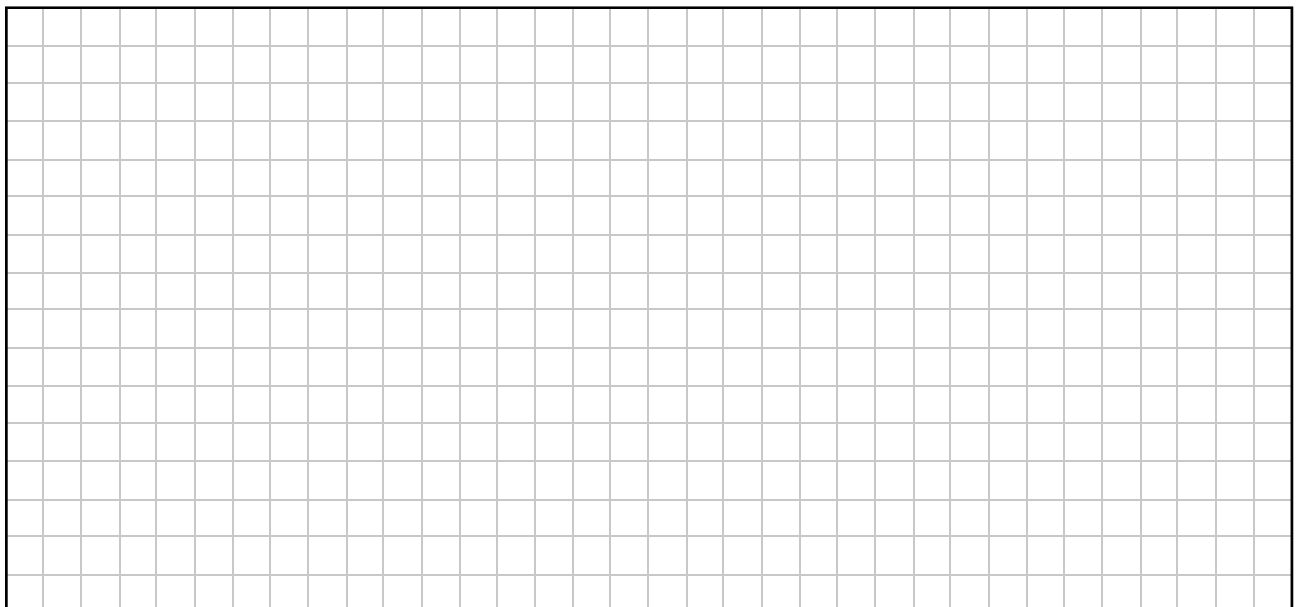

Question 3

- (a) A particle has initial displacement s_0 from a fixed point P . It moves away from P with initial velocity u and constant acceleration $a = \frac{dv}{dt} = \frac{d^2s}{dt^2}$.

Use calculus to derive an expression for s , the displacement of the particle from P at any time t .

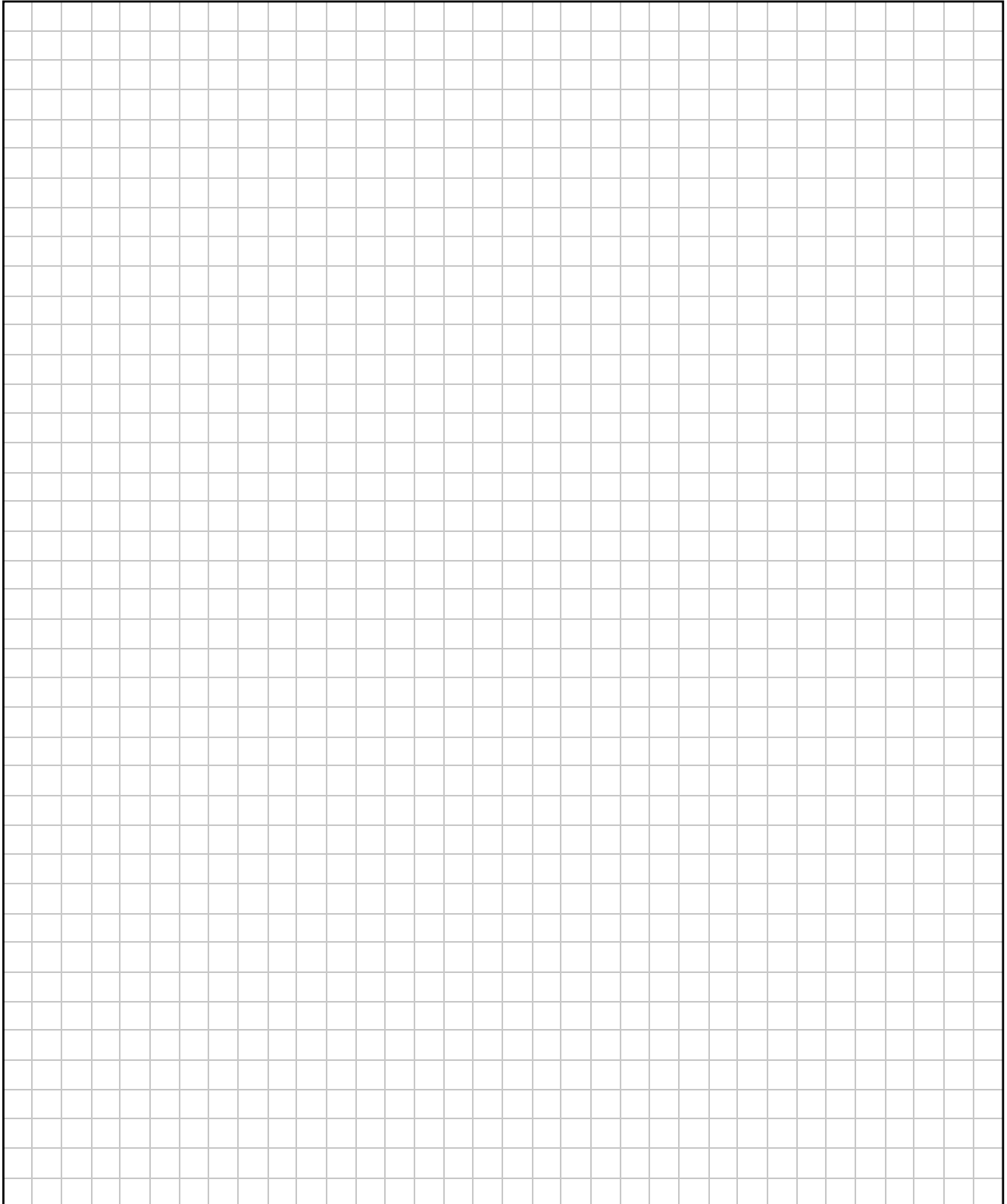

(b) Two athletes, Brian and Clara, are taking part in a relay race. Brian is preparing to hand over the baton to Clara. During the hand-over of the baton the athletes need to be running in the same straight line and at the same velocity.

As Brian approaches Clara's position at a constant speed of 11 m s^{-1} , Clara starts running from rest with constant acceleration f .

A short time later Brian begins to decelerate at 2 m s^{-2} .

Clara receives the baton 2.5 s after she starts running.

The baton is exchanged when Clara is 75 cm ahead of Brian and when both athletes have a speed of 8 m s^{-1} .

After the baton is exchanged, Brian continues to decelerate at 2 m s^{-2} until he comes to rest. Clara continues to accelerate at f until she reaches her maximum speed of 12 m s^{-1} , which she then maintains.

(i) Calculate the time it takes for Brian to decelerate before he exchanges the baton.



- (ii) Using the axes below, draw an *accurate* velocity-time graph for the motion of each runner. Time is measured from the instant that Clara begins to run.

Relevant calculations should be shown in the space below.

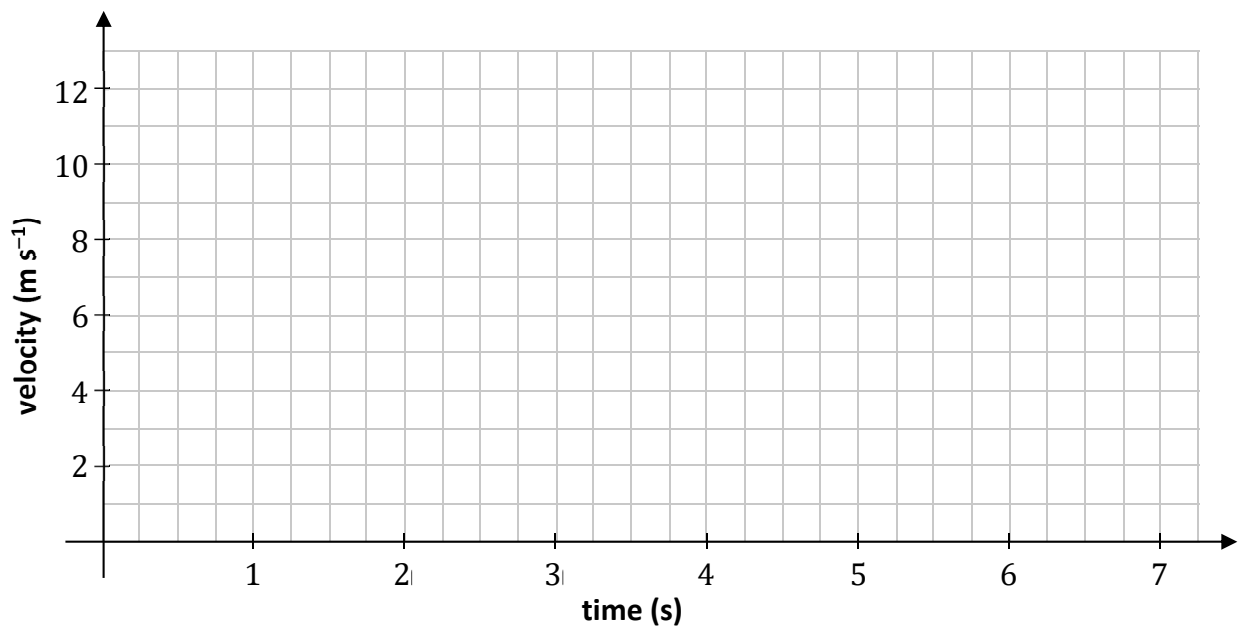
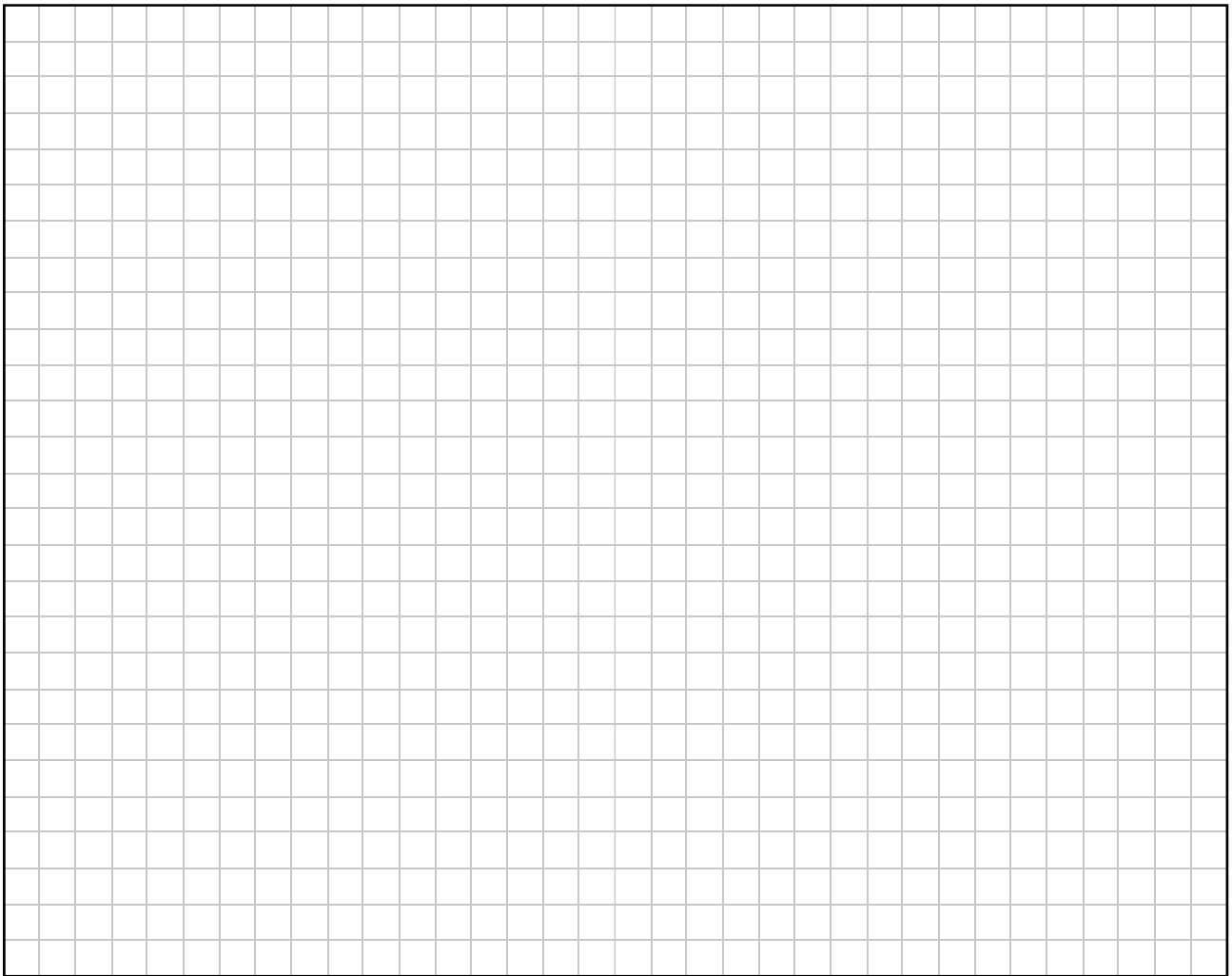

(iii) Calculate the distance between the two athletes when Clara begins to run.

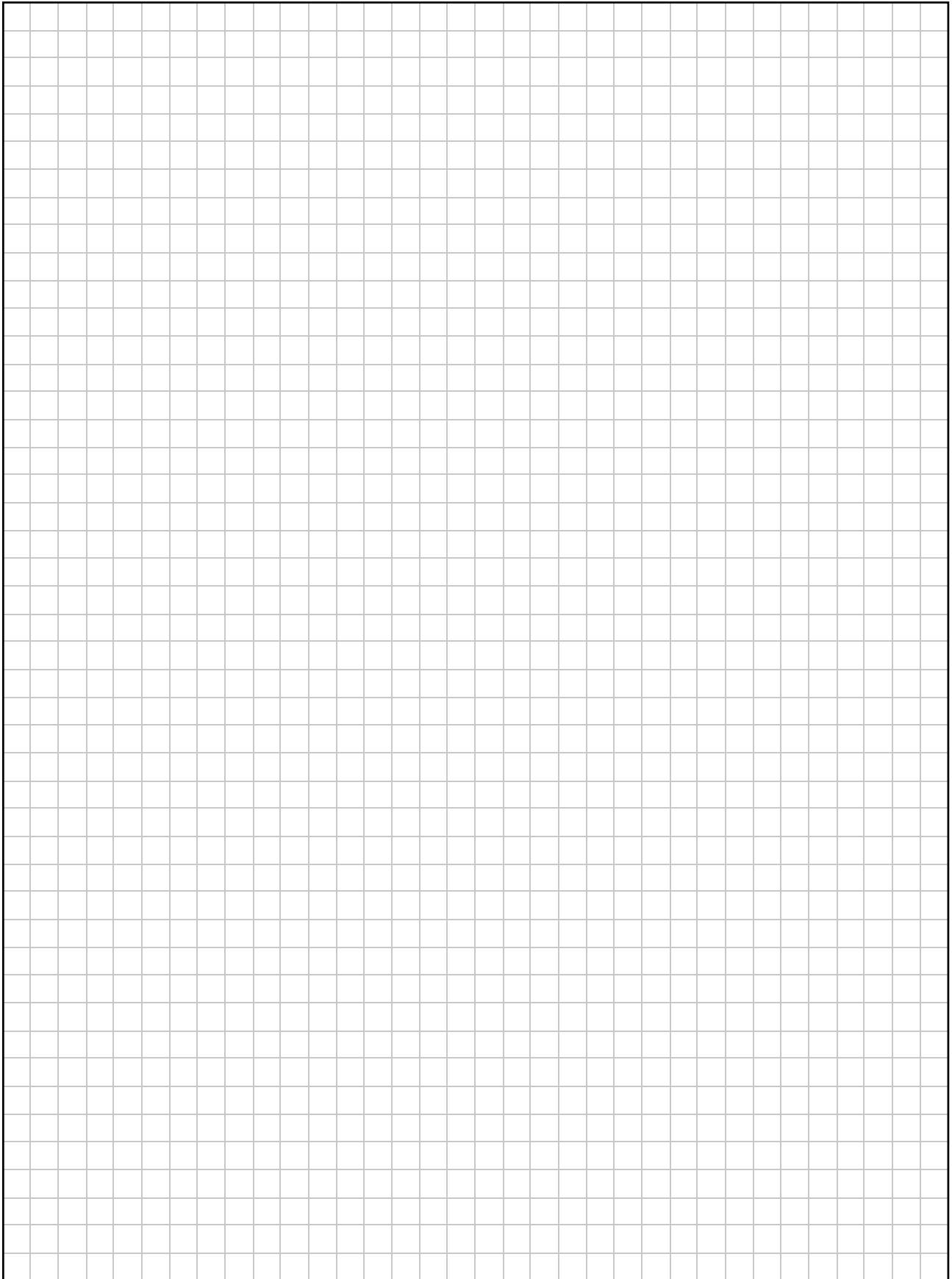

Question 4

- (a) A ball is projected from a point on horizontal ground, with initial speed u and at an angle α to the horizontal. The ball reaches a maximum height of H_0 above the horizontal. Upon landing, the ball bounces with a maximum height of H_1 .

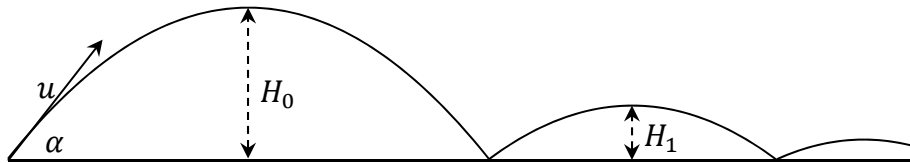

The coefficient of restitution between the ball and the ground is e .

- (i) Calculate $\frac{H_0}{H_1}$.

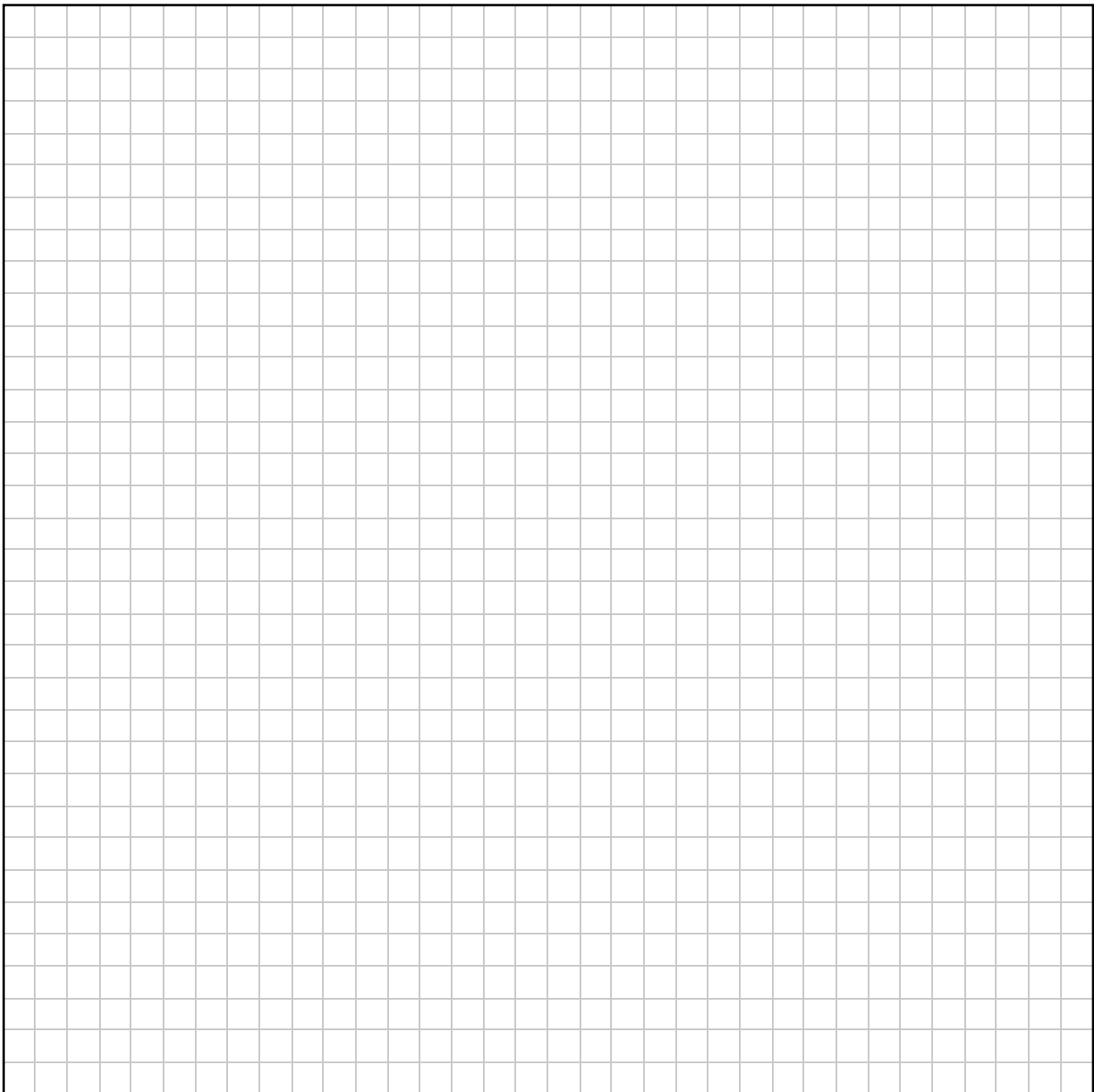

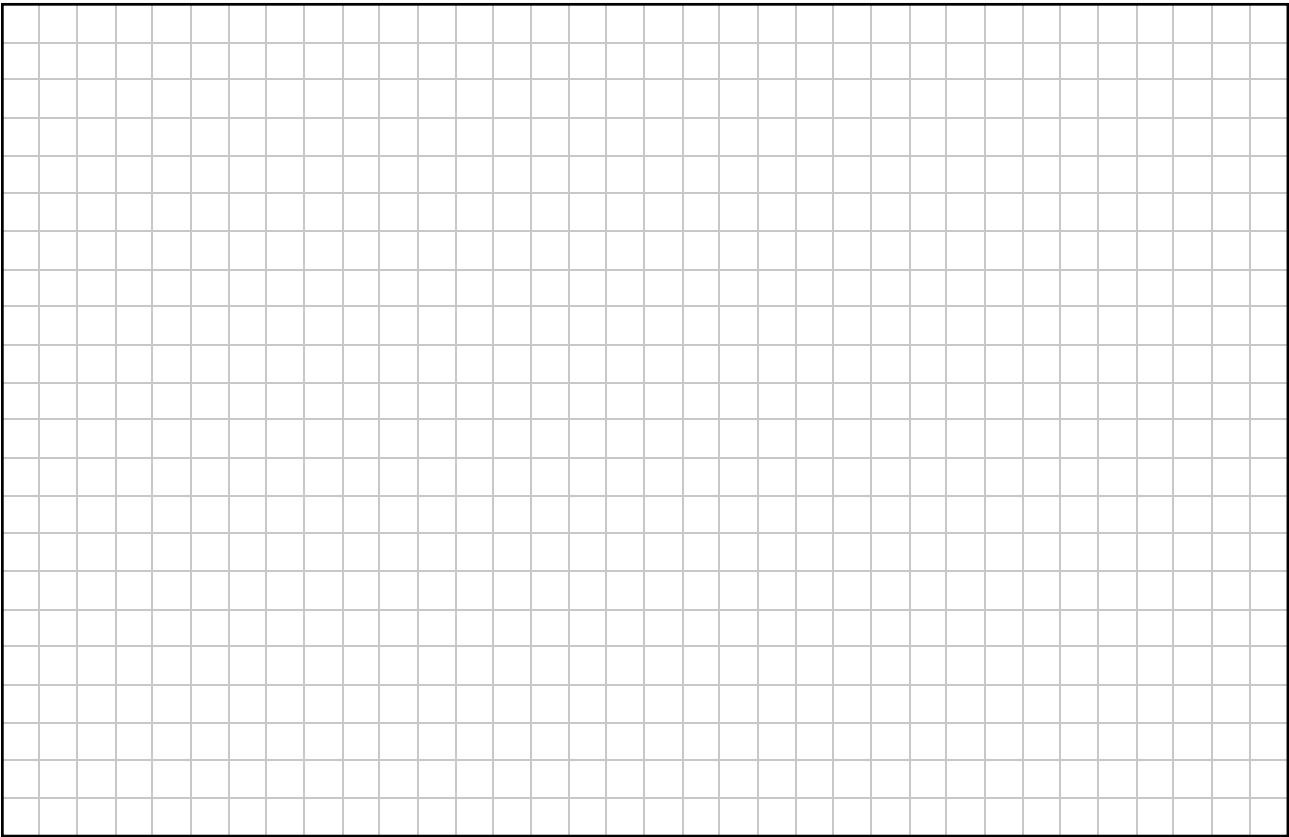

(ii) The ball continues bouncing. Find an expression (in terms of e and H_0) for H_5 , the maximum height of the ball after it lands on the ground for the fifth time.

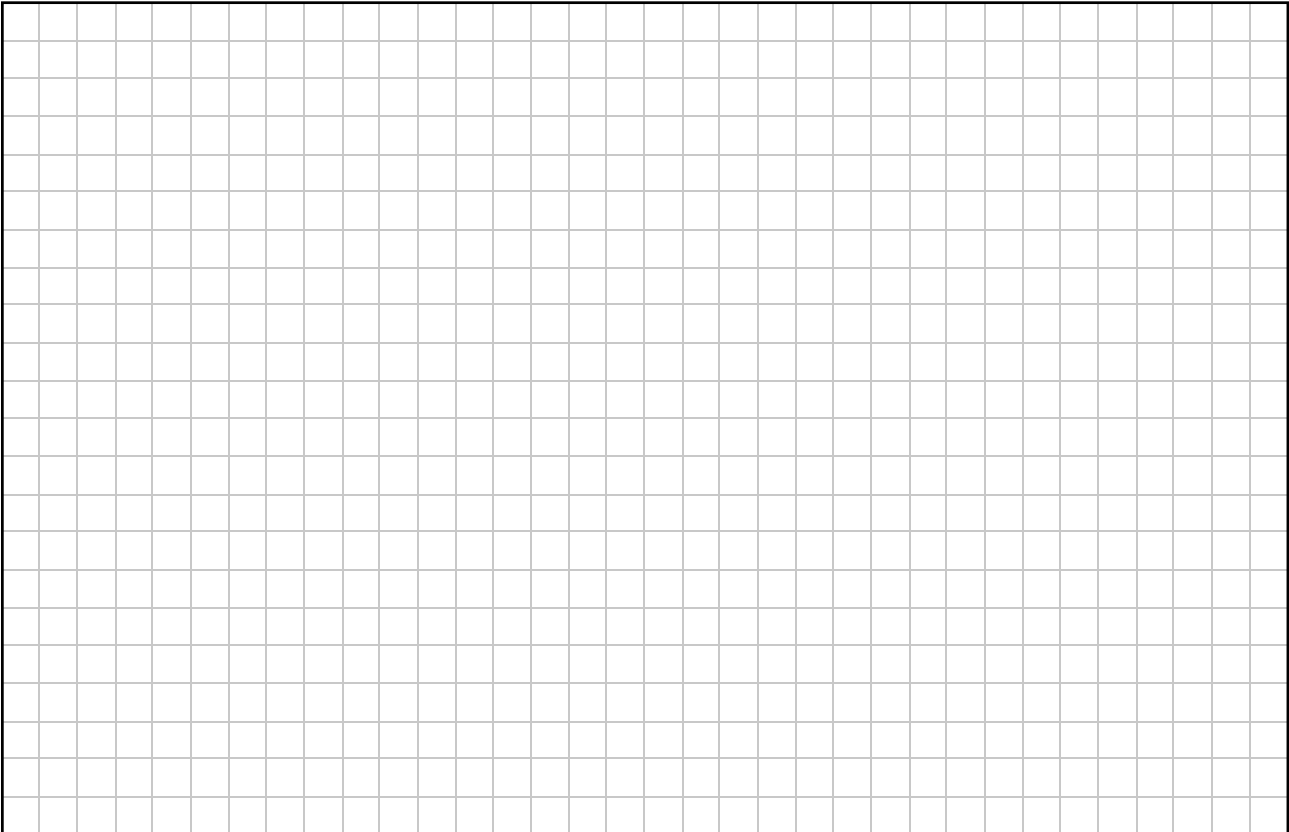

- (b) Two identical smooth spheres, P and Q , each moving with speed u , collide obliquely. The line joining their centres at the point of impact is along the \vec{i} axis.

Before the collision, the velocity of sphere P makes an angle θ with the \vec{i} axis and the velocity of sphere Q makes an angle θ with the \vec{j} axis, as shown in the diagram.

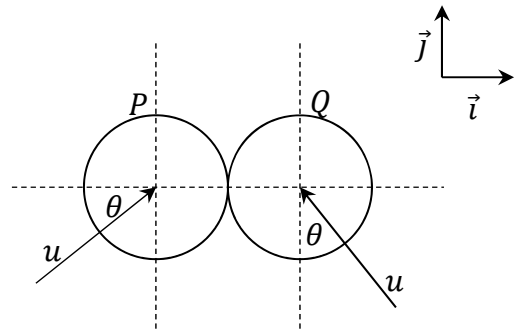

The coefficient of restitution between the spheres is e , where $0 \leq e \leq 1$.

After the collision sphere Q moves off parallel to the \vec{j} axis.

- (i) Show that $e = \frac{\tan \theta - 1}{\tan \theta + 1}$.

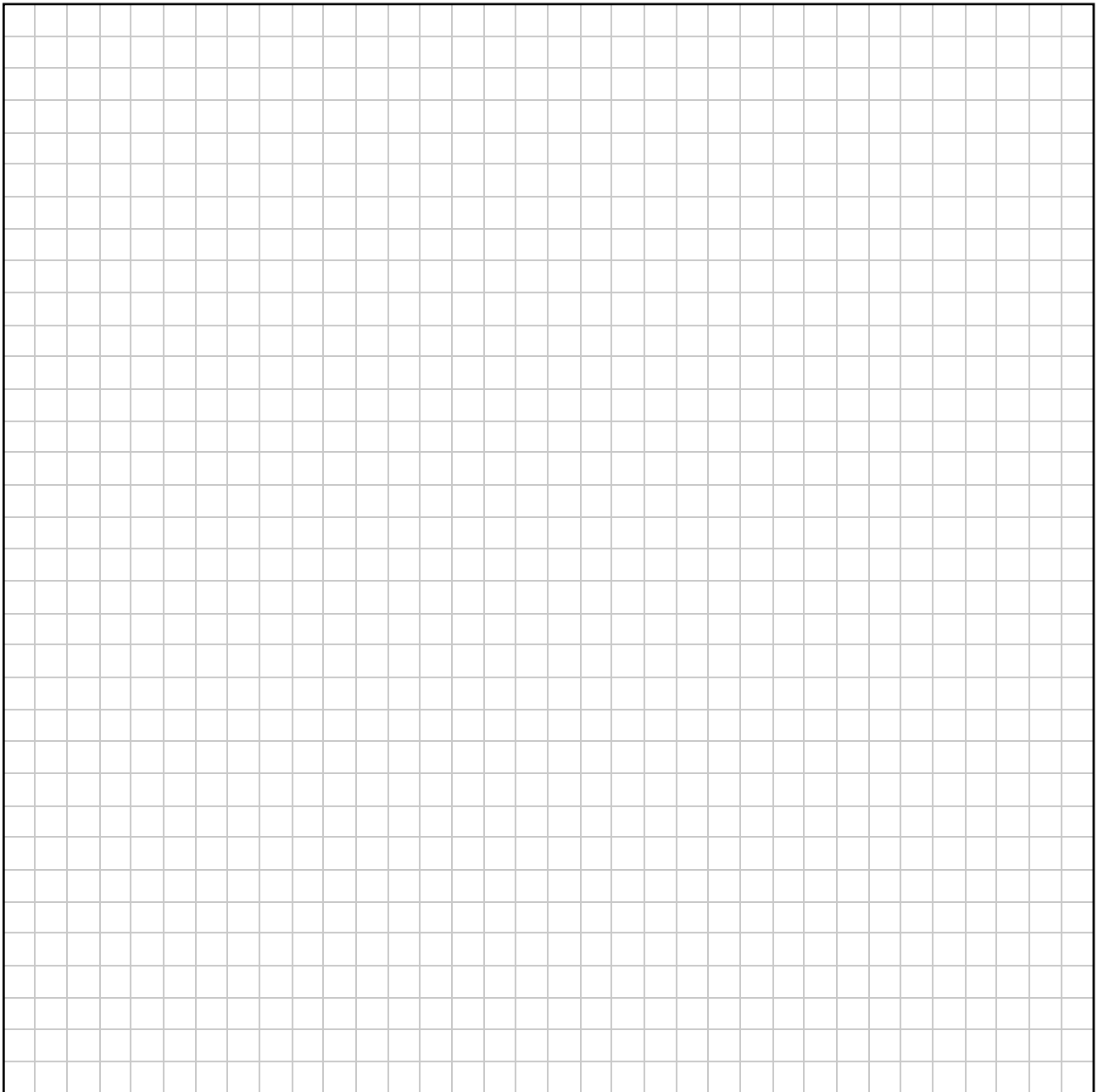

(ii) If 25% of the spheres' total kinetic energy is lost during the collision, calculate θ and e .

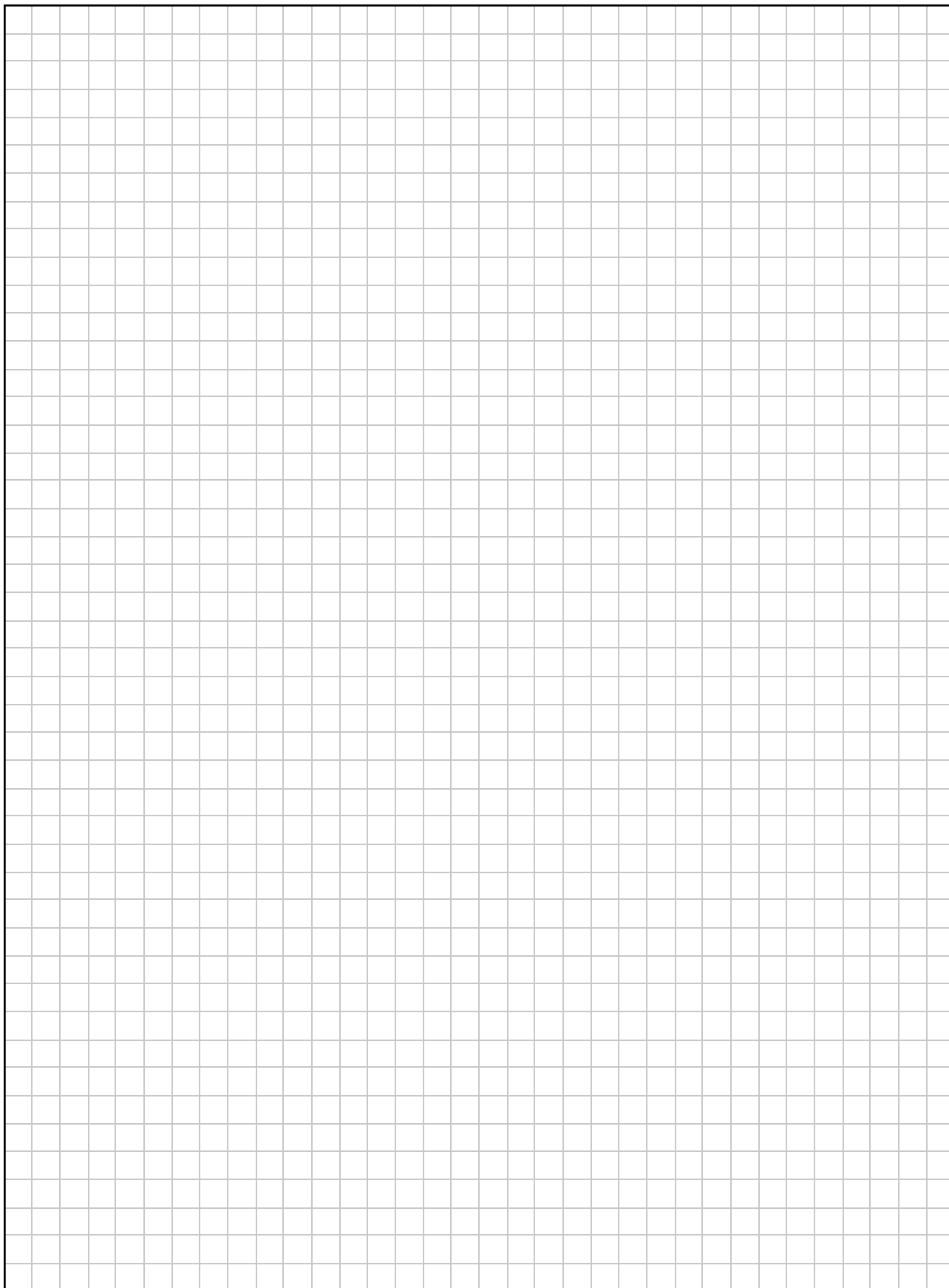

Question 5

- (a) In the network shown below, the edges represent roads and the nodes represent the junctions of two or more roads, labelled with the letters *A* to *N*. The weight of each edge represents the distance (in km) between a pair of junctions.

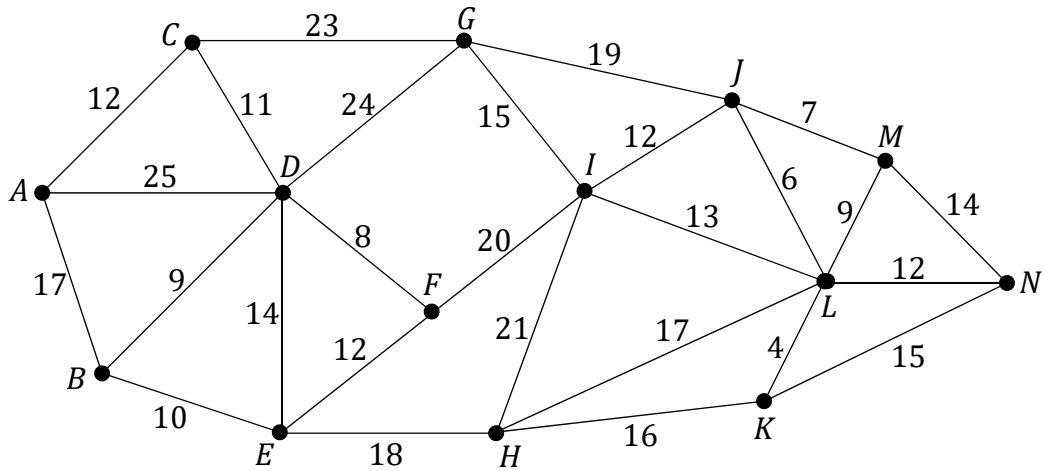

- (i) Use Dijkstra's algorithm to find the shortest path from junction *A* to junction *N*. Calculate the length of the shortest path. Relevant supporting work must be shown.

A large grid area provided for showing the work of Dijkstra's algorithm.

- (ii) A group of engineers want to close down some of the roads to carry out maintenance work. They wish to close down as much of the road network as possible while still allowing a person to drive between any two junctions on the network.

Using an appropriate algorithm, find the minimum spanning tree for the network.
Name the algorithm you used. Relevant supporting work must be shown.

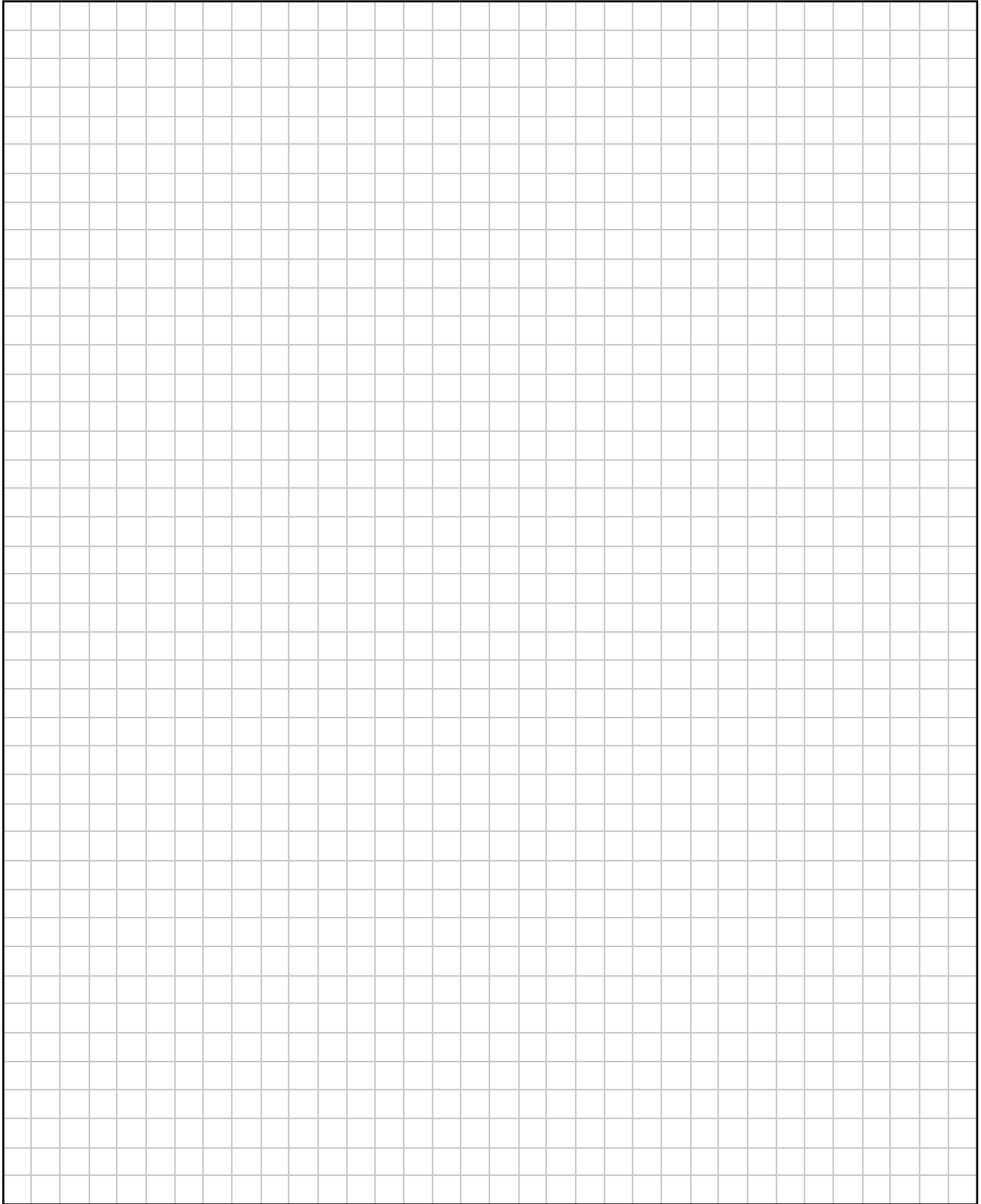

- (b) A rumour may be spread when a person who has heard the rumour interacts with a person who has not heard the rumour.

Therefore, the rate of spread of a rumour within a group can be modelled as being proportional to the product of the number of people in the group who have heard the rumour and the number of people in the group who have not heard it.

A student models the rate at which a certain rumour spreads within a school population of 1200 students using the differential equation:

$$\frac{dR}{dt} = kR(1200 - R)$$

where $R(t)$ is the number of students of that school who have heard the rumour at time t , measured in days, and where k is a positive constant.

On Monday morning ($t = 0$), 100 students had heard the rumour.

- (i) Solve the differential equation to find an expression that relates R , k and t .

Note that $\frac{1}{y(x-y)} = \frac{1}{x} \left(\frac{1}{y} + \frac{1}{x-y} \right)$.

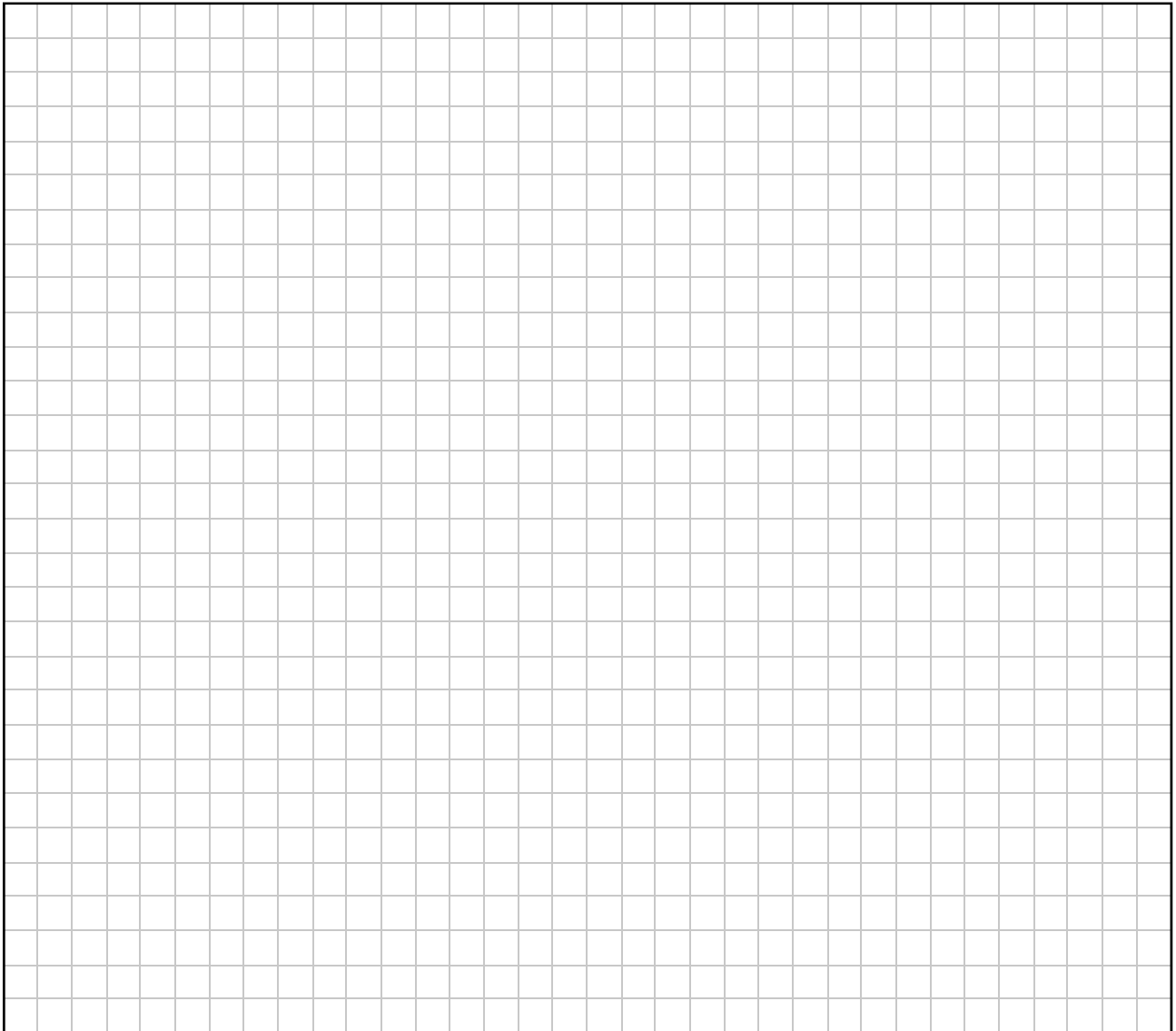

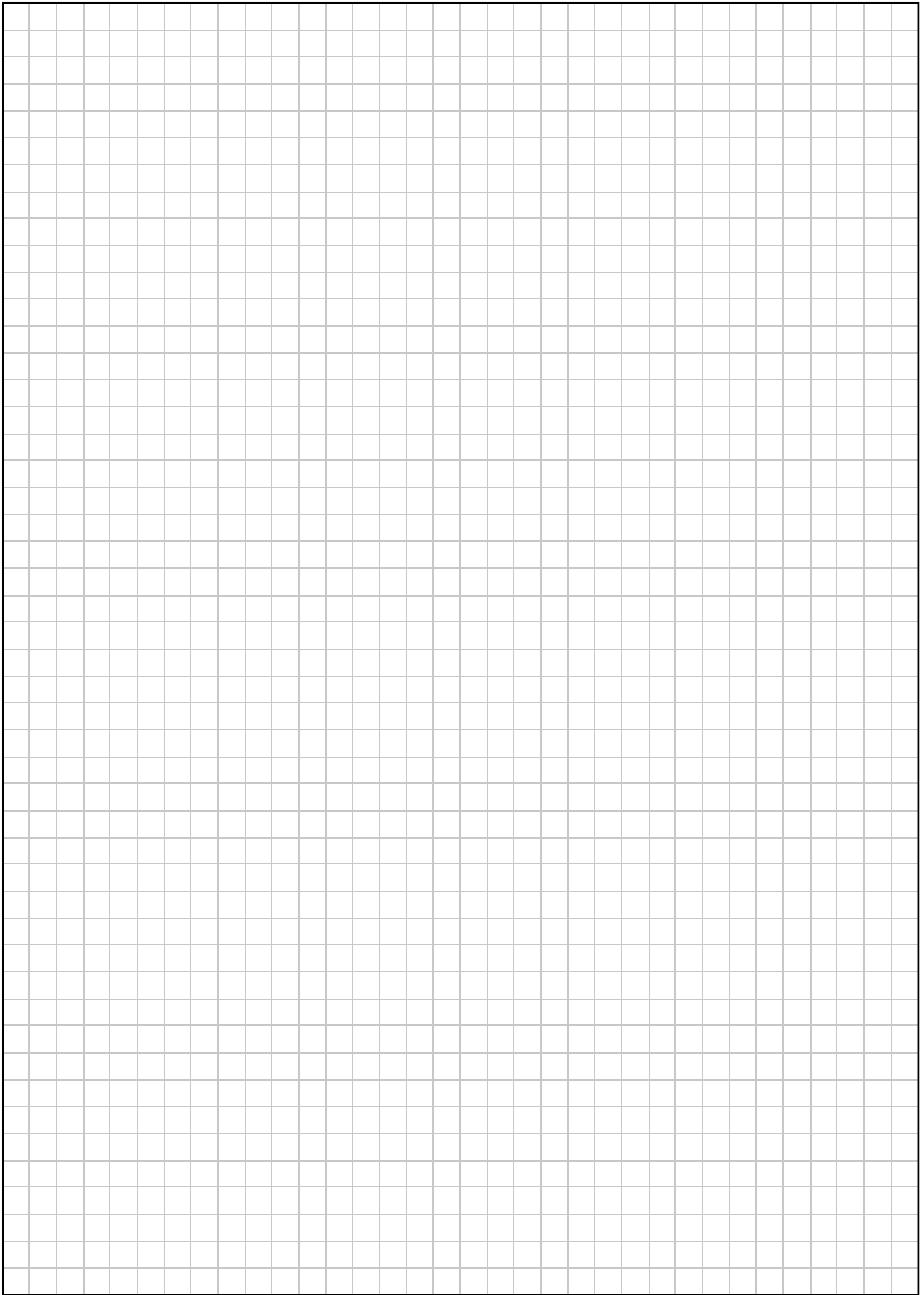

(ii) By Wednesday morning 250 students had heard the rumour. Calculate the value of k .

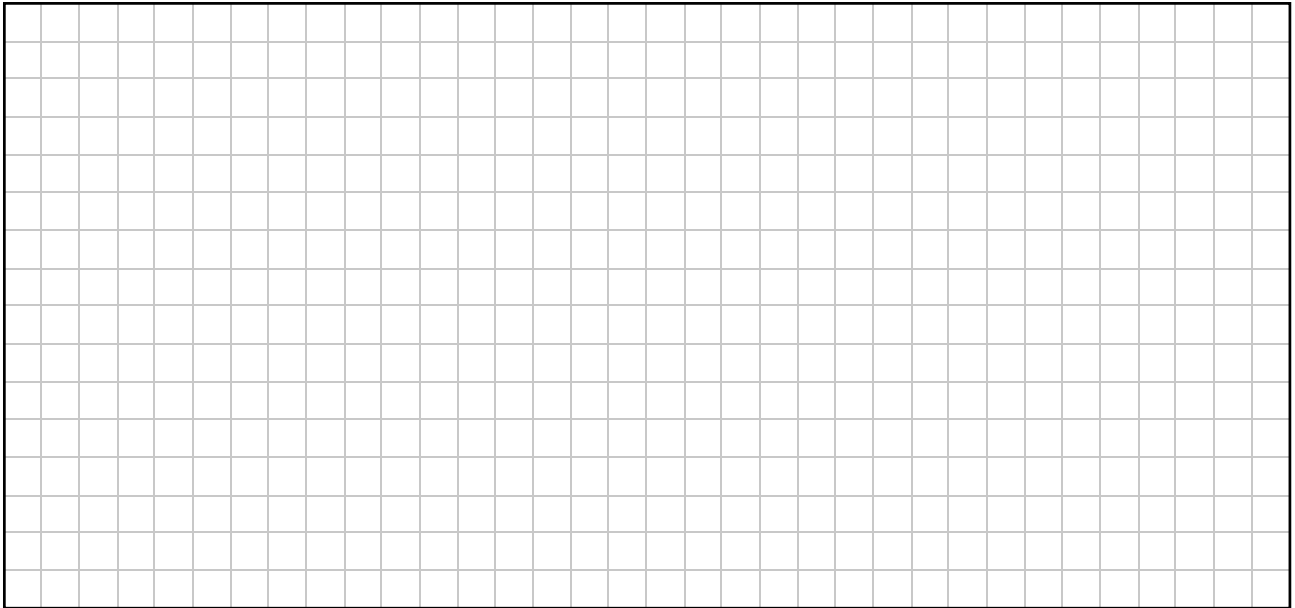

(iii) Sketch the shape of a graph of R against t to show how the model predicts the spread of the rumour.

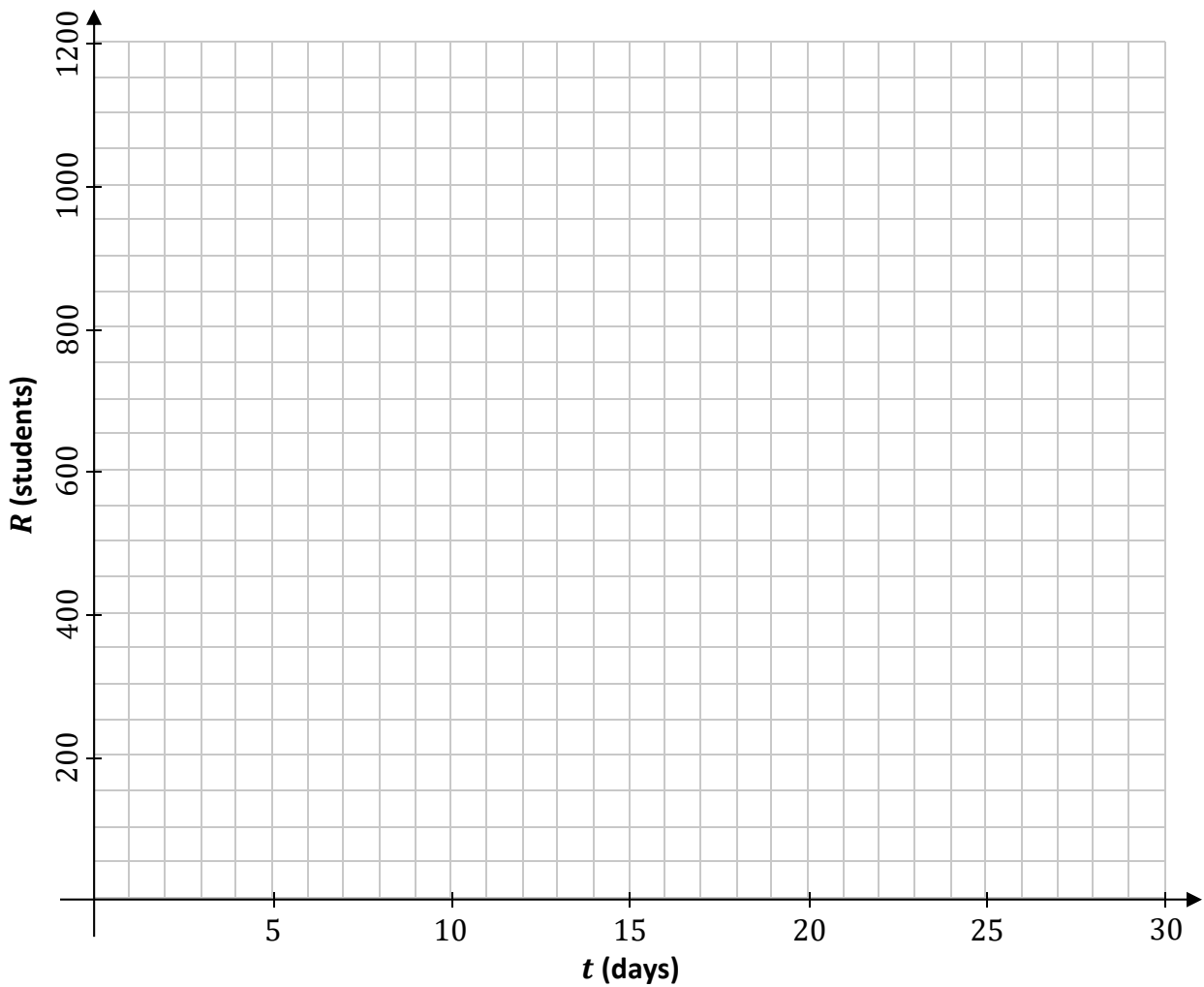

- (iii) Use a dot product calculation to show that the car's velocity and displacement are always perpendicular to each other.

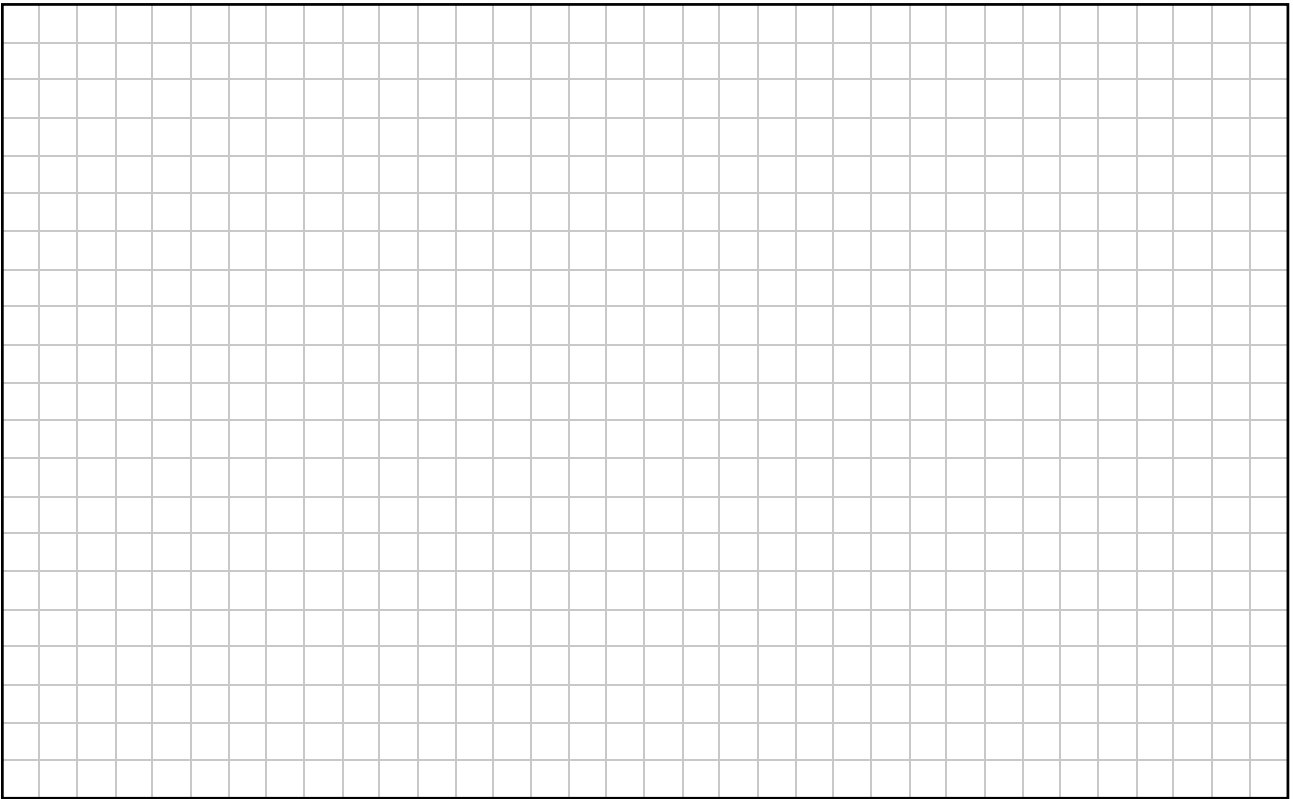

- (iv) Show that the acceleration of the car is always directed towards O .

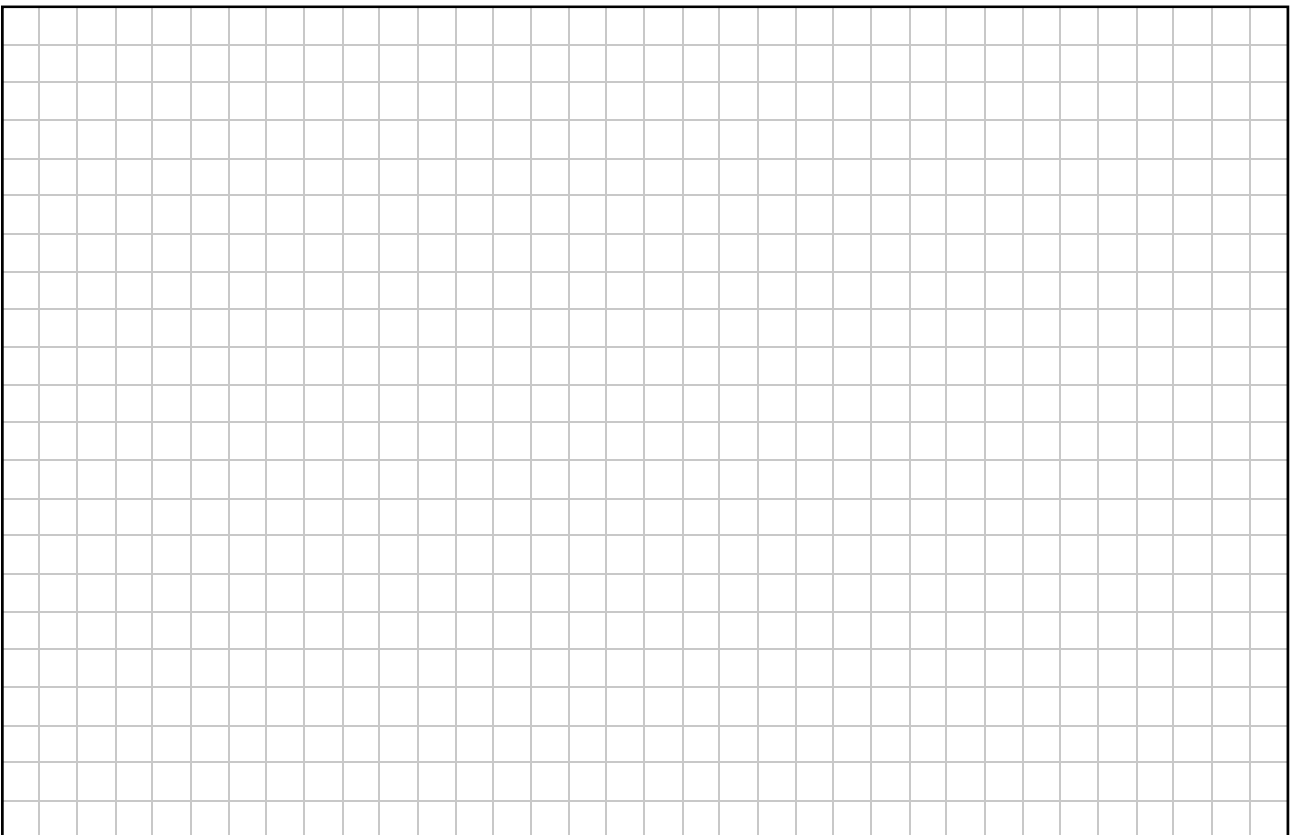

- (v) Derive an expression for the maximum velocity the car could have as it travels around the roundabout, without slipping. Your expression should be written in terms of r , g and μ , the coefficient of friction between the car and the road.

- (vi) Use dimensional analysis to show that the units for the expression you derived in part (v) are equivalent to the units for velocity.

- (vii) Do you think the assumptions made in developing this model were appropriate? Explain your answer.

Question 7

- (a) A bungee jumper of mass 75 kg jumps from a height of 35 m above water. The jumper is tied to an elastic rope of natural length 12 m and elastic constant 100 N m^{-1} .
- (i) Derive an expression for the work done when a spring of elastic constant $k \text{ N m}^{-1}$ is stretched by $x \text{ m}$.

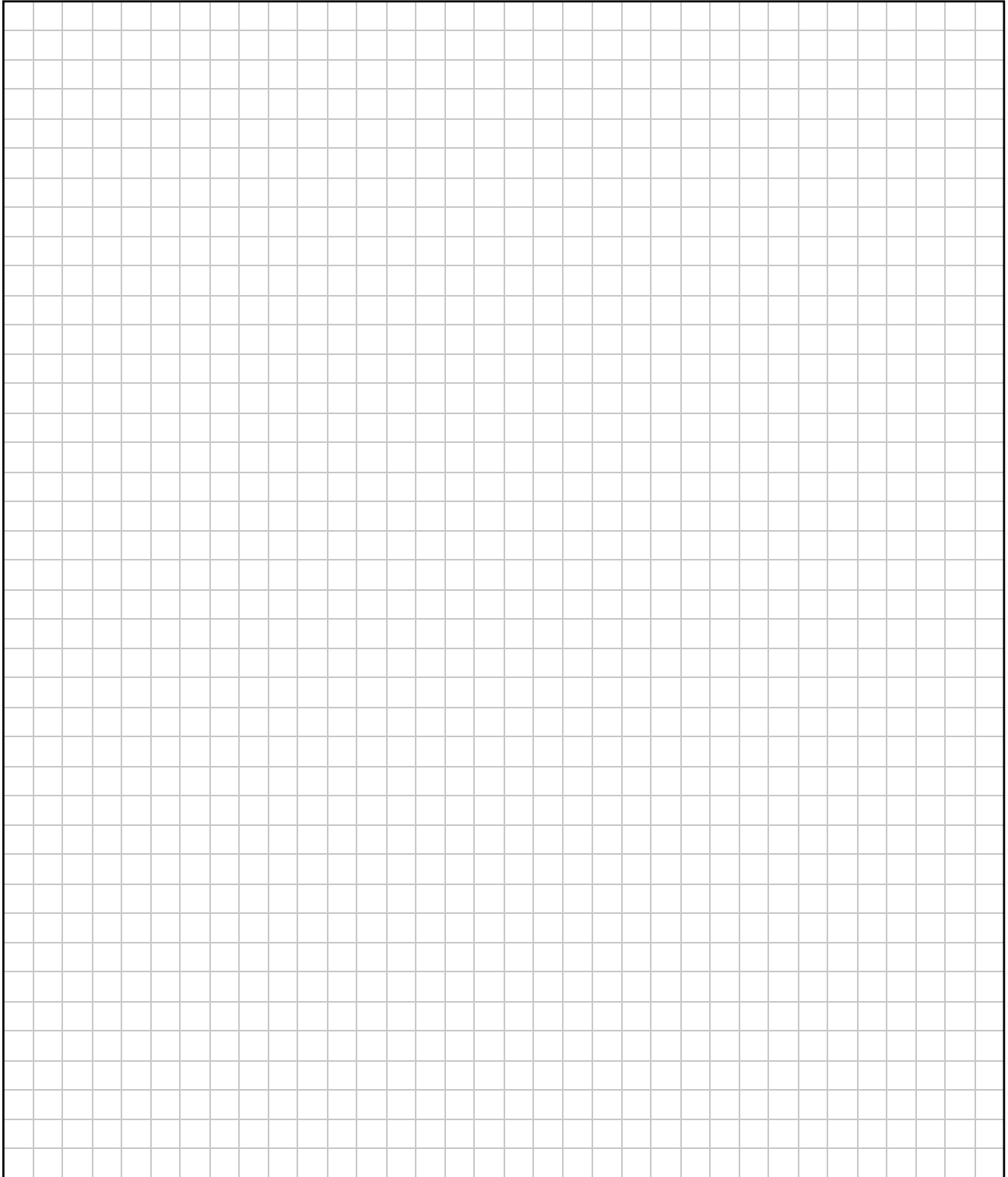

- (ii) The motion of the bungee jumper may be modelled using the principle of conservation of energy. Using this model, calculate the distance between the water and the bungee jumper when the bungee jumper is at the lowest point of their motion.

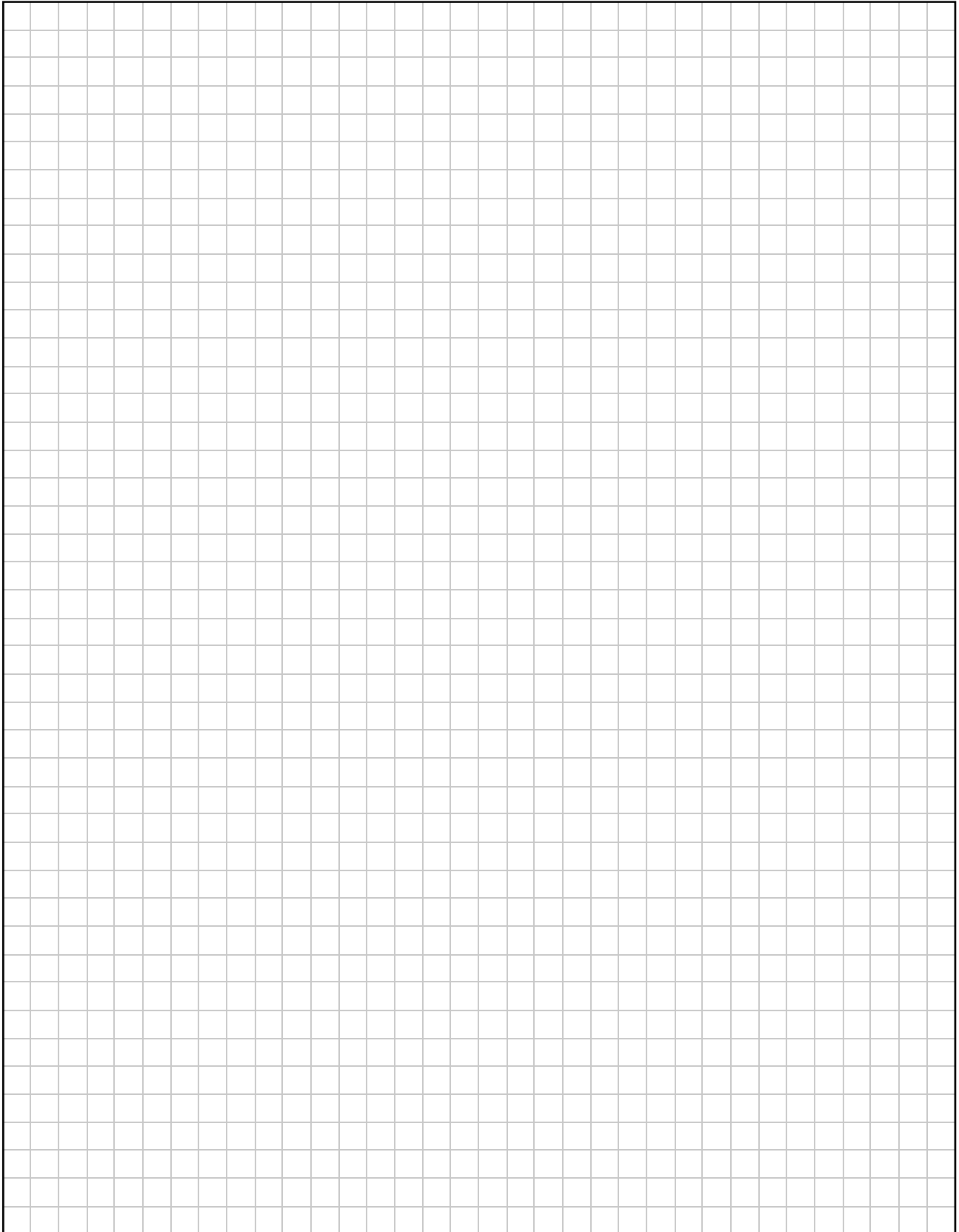

- (b)** A small smooth moveable disk D , of mass 0.2 kg , rests on a light inextensible string. One end of the string is connected to block B , of mass 4 kg , which rests on a rough plane inclined at 30° to the horizontal. The other end of the string is connected vertically to a fixed point.

The coefficient of friction between block B and the inclined plane is $\frac{1}{10}$.

When the system is released from rest, D moves upwards with acceleration a .

The tension in the string is T .

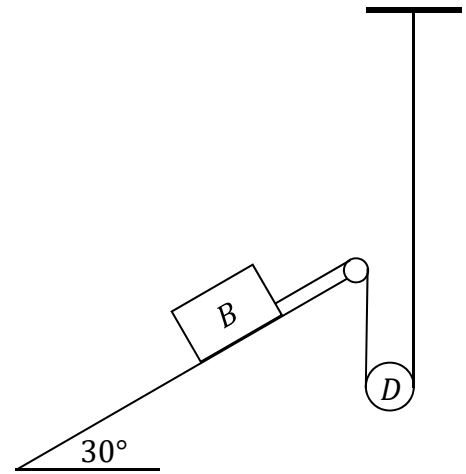

- (i)** Show, on separate diagrams, the forces acting on block B and disk D while they are moving.

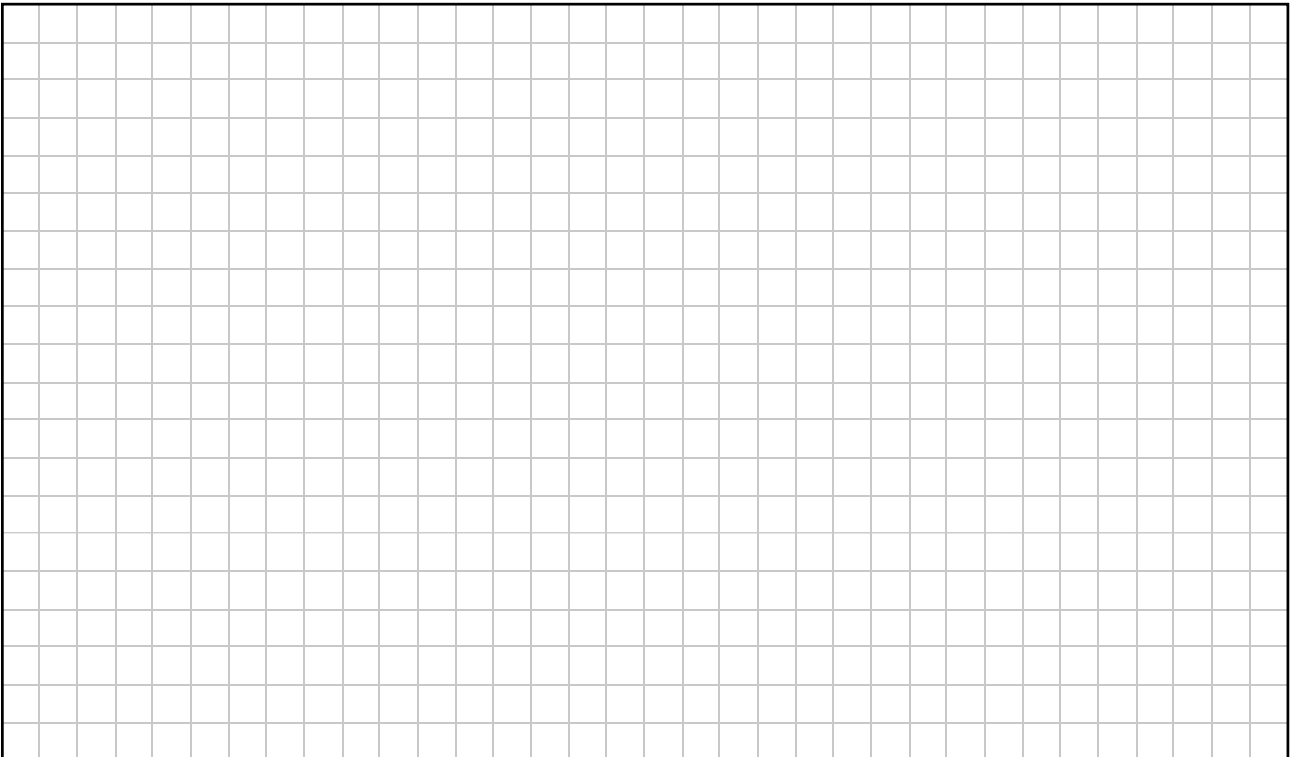

- (ii)** Explain why the acceleration of B is $2a$.

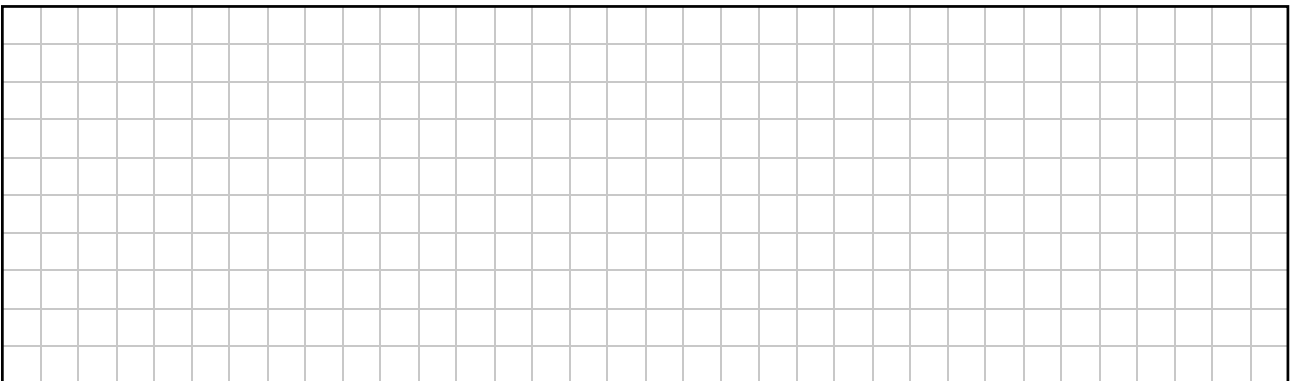

(iii) Calculate a and T .

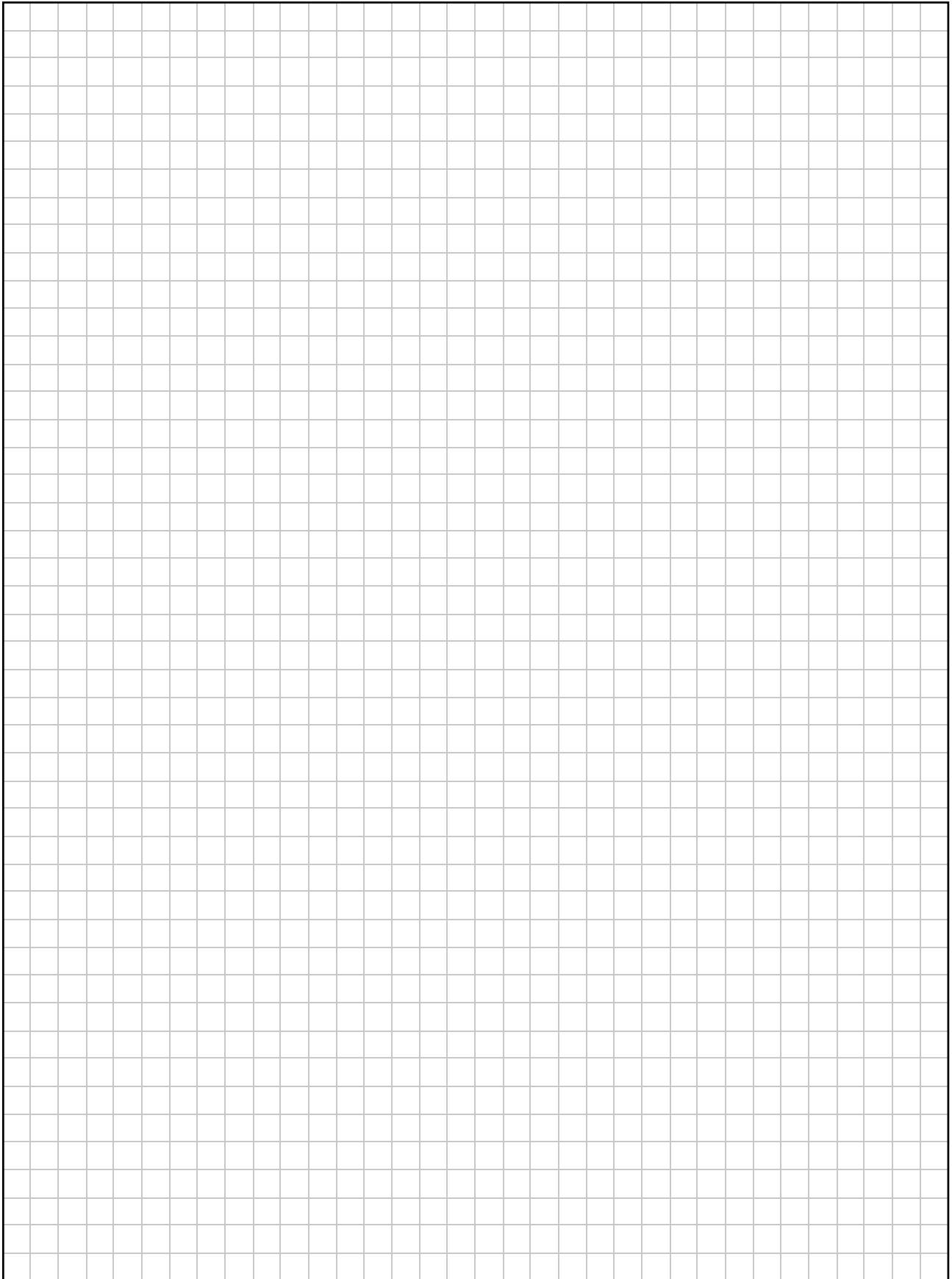

Question 8

A group of scientists are investigating the population, P , of rabbits on a certain island. They estimate that there are 8000 rabbits on the island and that the population is growing at a constant rate of 3% per year.

The scientists plan to remove a number of rabbits from the island every year, to help populate another habitat. They develop mathematical models to predict how P will change if B rabbits are removed from the island every year.

The first model which the scientists develop uses a difference equation to express the population of rabbits in year $n + 1$ in terms of the population in year n .

The difference equation is:

$$P_{n+1} = 1.03P_n - B$$

where $n \geq 0$, $n \in \mathbb{Z}$ and $P_0 = 8000$.

- (i) Solve this difference equation to find an expression for P_n in terms of n and B .

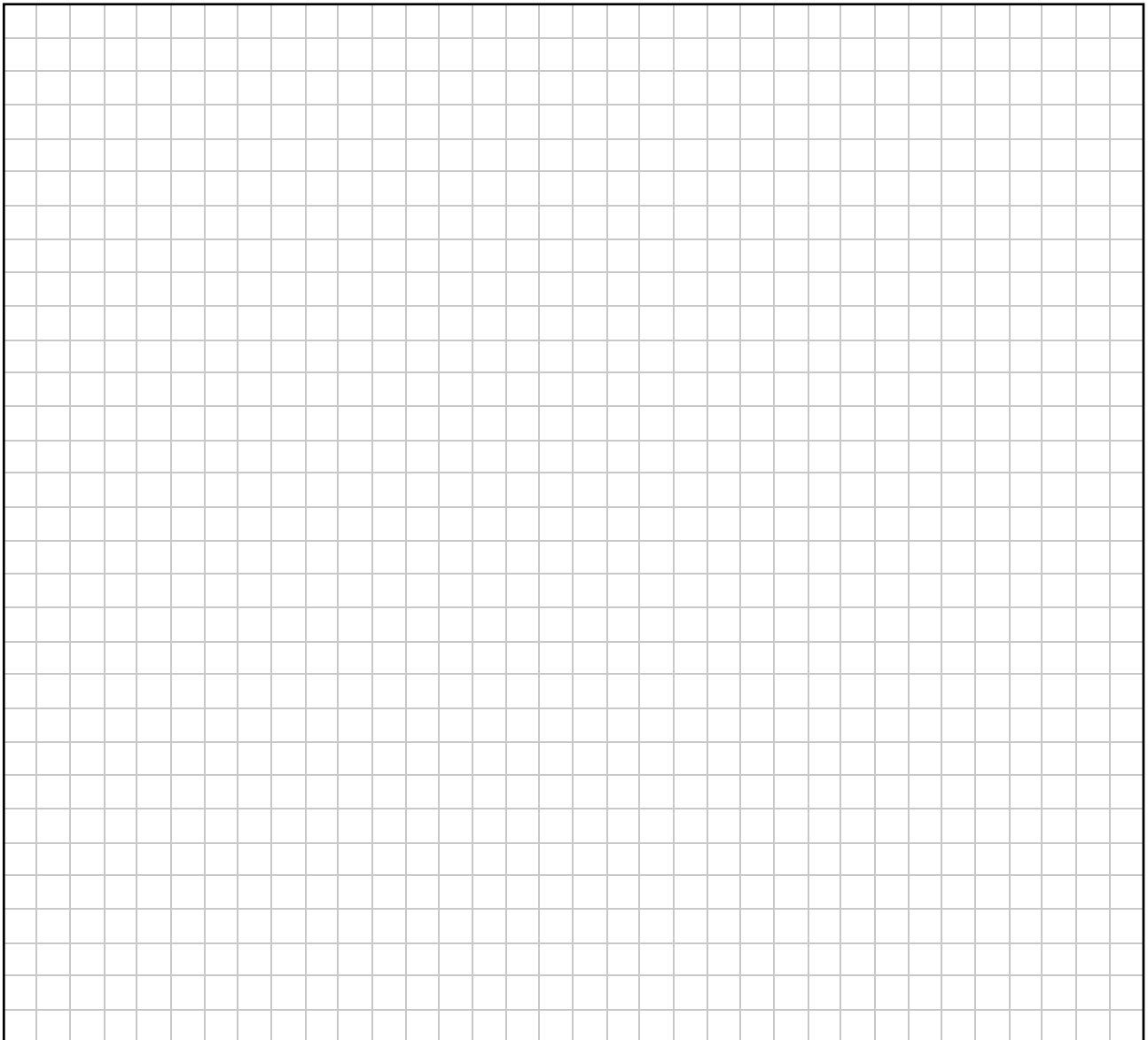

The second model which the scientists develop uses a differential equation to express the rate of change of P with respect to n , time measured in years.

The differential equation is:

$$\frac{dP}{dn} = 0.03P - B$$

where $n \geq 0$, $n \in \mathbb{R}$ and $P(0) = 8000$.

(ii) Solve this differential equation to find an expression for P in terms of n and B .

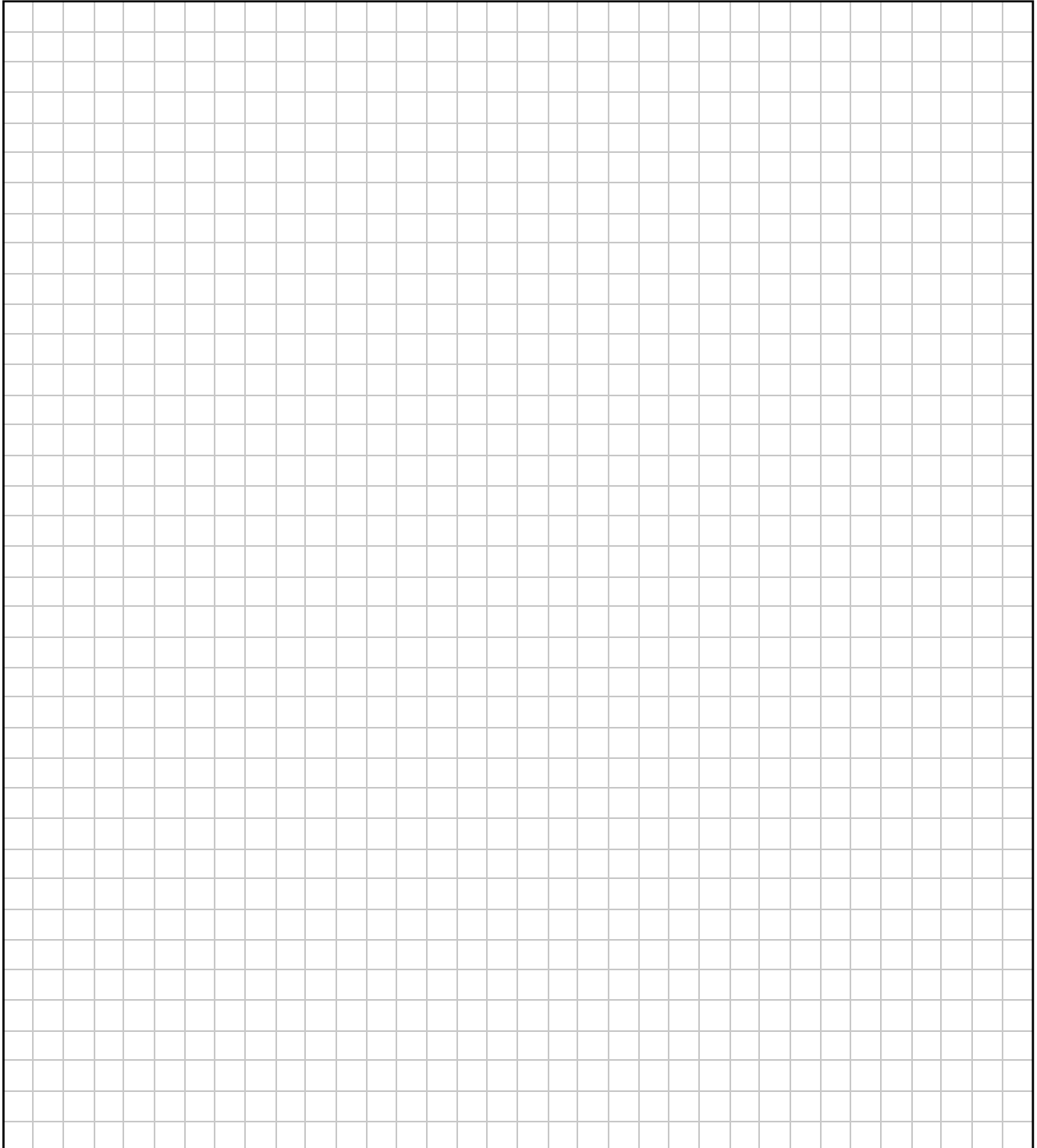

The scientists want to know what each model predicts the rabbit population on the island will be after 50 years, if 200 rabbits are removed each year.

(iii) Calculate P_{50} using the first model and $P(50)$ using the second model, when $B = 200$.

(iv) Each of these models makes a different assumption about the removal of the rabbits from the island. What are the two different assumptions?

(v) The scientists want to know what value of B should be chosen so as to keep the rabbit population on the island constant. Calculate this value of B using either model.

Page for extra work.

Label any extra work clearly with the question number and part.

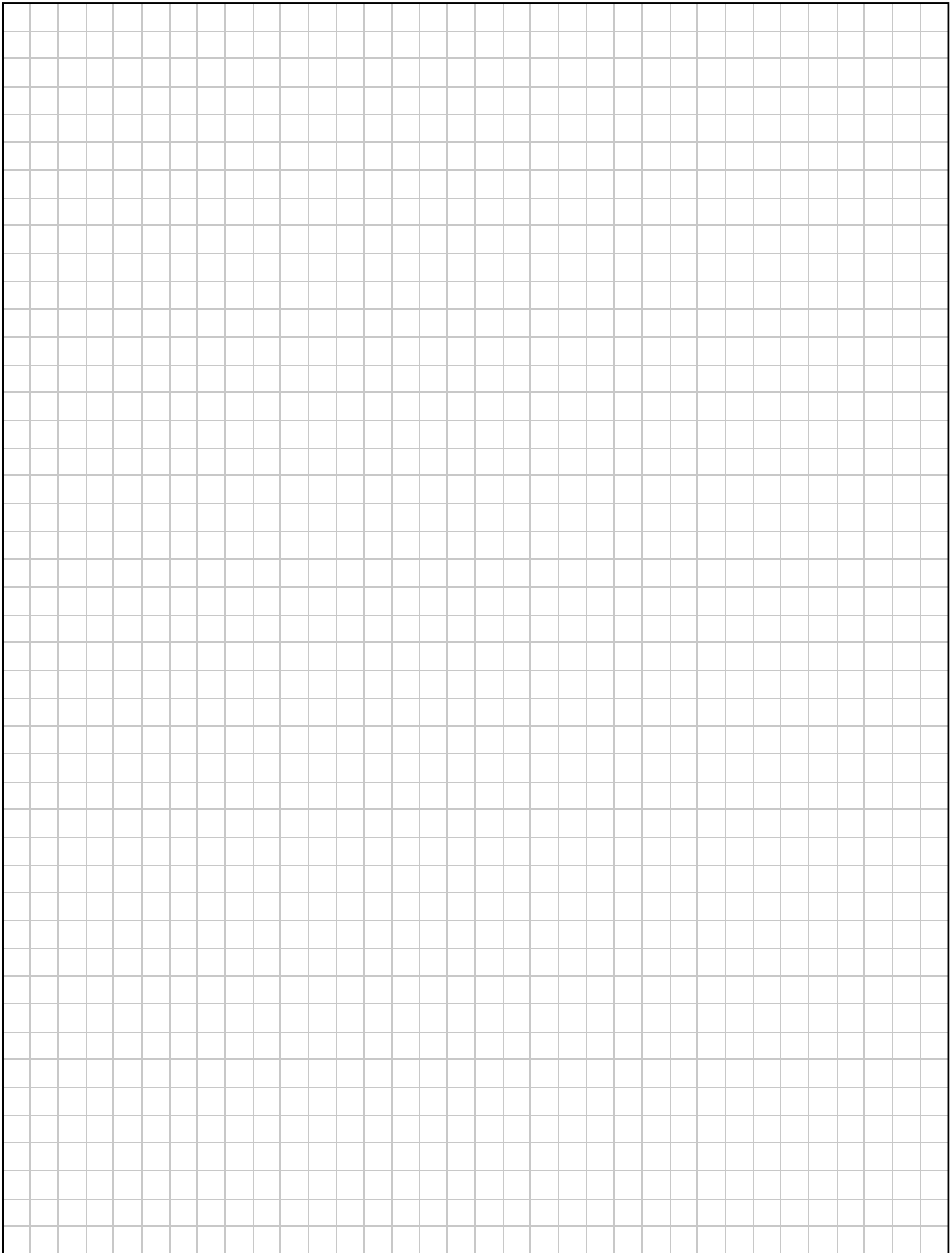

Page for extra work.

Label any extra work clearly with the question number and part.

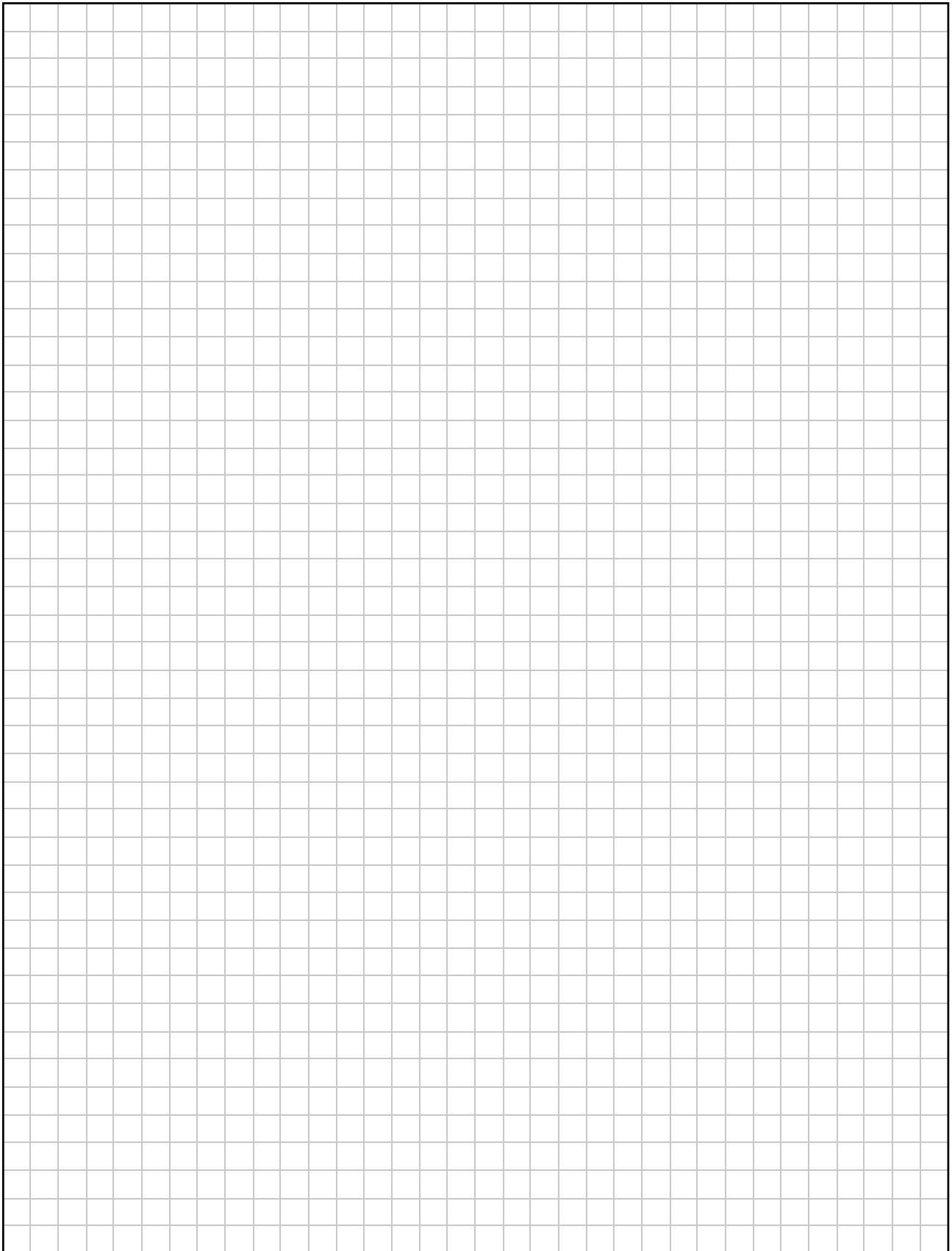

Page for extra work.

Label any extra work clearly with the question number and part.

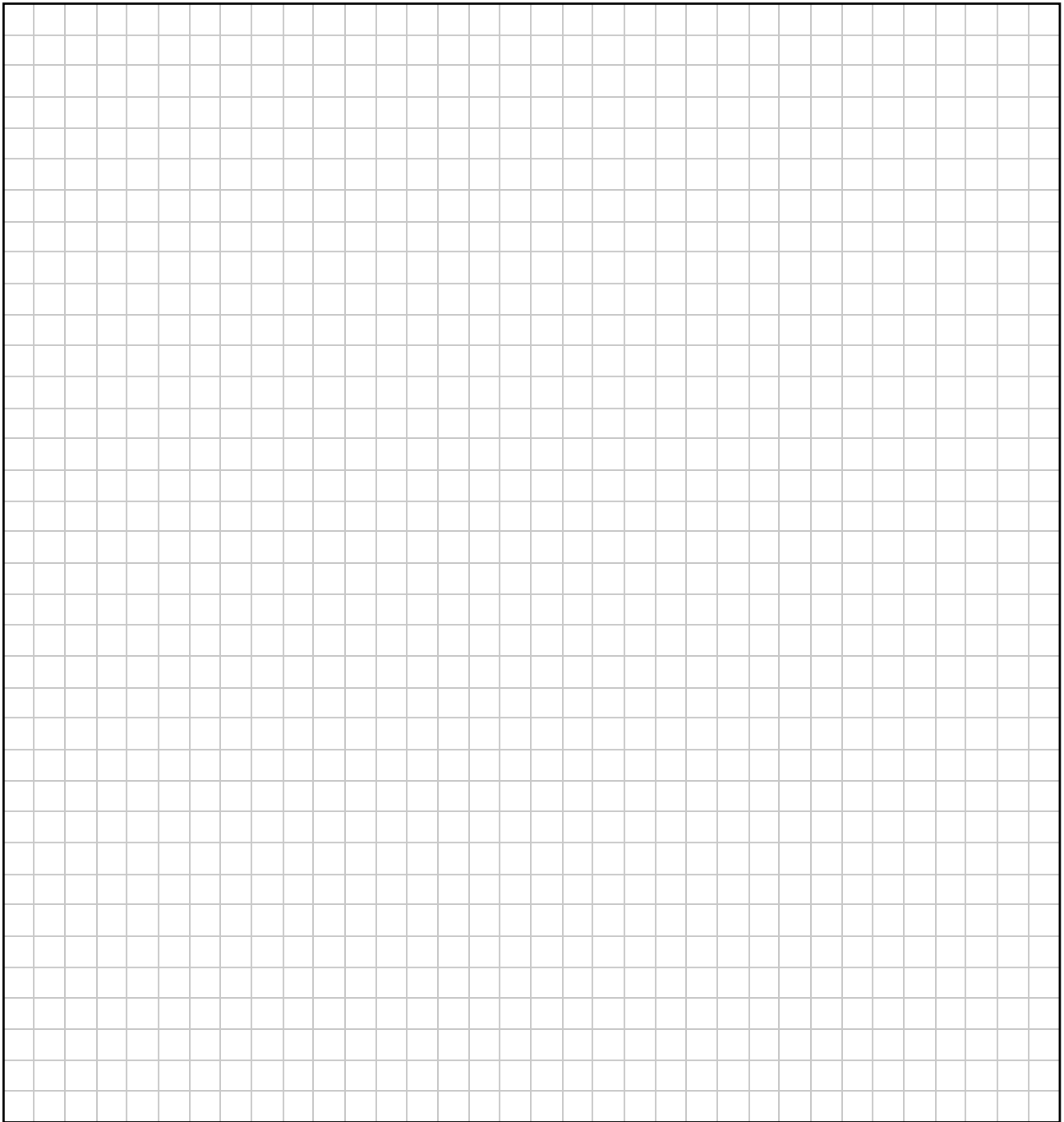

Acknowledgements

Images

Image on page 6:	State Examinations Commission
Image on page 8:	State Examinations Commission
Image on page 14:	State Examinations Commission
Image on page 16:	State Examinations Commission
Image on page 18:	State Examinations Commission
Images on page 23:	thejournal.ie; State Examinations Commission
Image on page 28:	State Examinations Commission

Copyright notice

This examination paper may contain text or images for which the State Examinations Commission is not the copyright owner, and which may have been adapted, for the purpose of assessment, without the authors' prior consent. This examination paper has been prepared in accordance with Section 53(5) of the *Copyright and Related Rights Act, 2000*. Any subsequent use for a purpose other than the intended purpose is not authorised. The Commission does not accept liability for any infringement of third-party rights arising from unauthorised distribution or use of this examination paper.

Leaving Certificate – Higher Level

Applied Mathematics

Sample Paper

2 hours and 30 minutes